



Model Number

RaDec-D
Radar sensor

Features

- Microwave motion sensor with intelligent functions
- Reliable detection of people and vehicles
- Simplest adjustment of the sensing range
- Wall and ceiling mountable
- Version with direction detection and cross-traffic suppression

Product information

The RaDec series consists of affordable radar motion sensors that not only combine all the key requirements of door manufacturers in a compact, stylish device, but are also user friendly and easy to install. An integrated microprocessor with 24 GHz microwave technology ensures a high level of reliability, even in difficult conditions. What's more, the sensor offers two adjustable detection areas, different operating modes, and an installation height of up to 4 m, and operates in a temperature range of -20 °C ... +60 °C. The -D version features rotation direction monitoring; a cross-traffic suppression system can also be connected to this version.

Release date: 2013-06-14 11:00 Date of issue: 2013-06-19 22:402_eng.xml

Dimensions

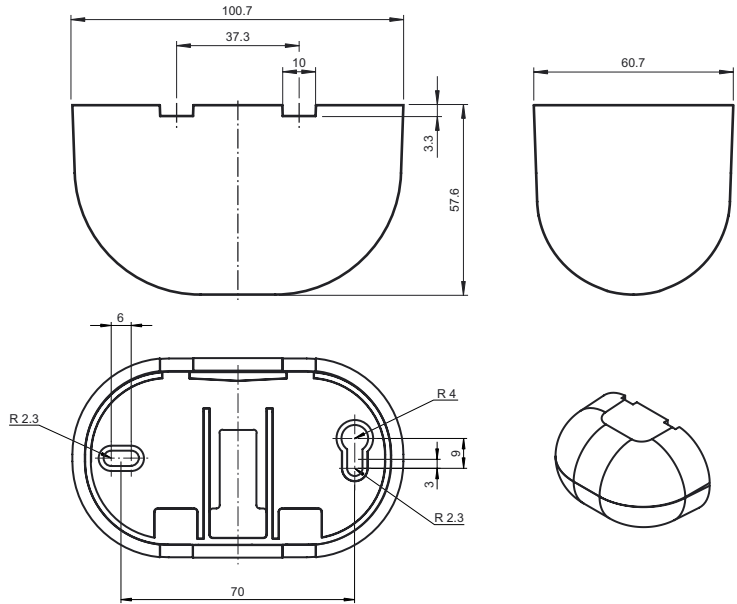

Electrical connection

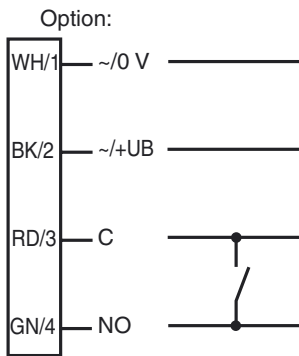

Indicators/operating means

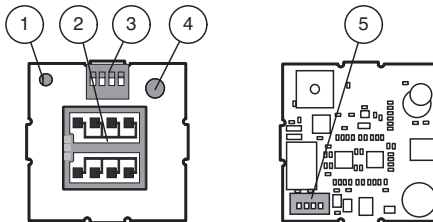

1	LED red
2	Antenna
3	DIP switch
4	Potentiometer
5	Connector

Technical data

General specifications

Sensing range	broad: 2000x 4500 mm (DxW) at 2200 mm mounting height and 30° tilt angle narrow: 4500x 2000 mm (DxW) at 2200 mm mounting height and 30° tilt angle
Function principle	Microwave module
Detection speed	min. 0.1 m/s
Marking	CE
Setting angle	0 ... 90 ° in 5 ° increments
Operating frequency	24.15 ... 24.25 GHz K-Band
Operating mode	Radar motion sensor
Transmitter radiated power (EIRP)	< 20 dBm

Functional safety related parameters

MTTF _d	300 a
Mission Time (T _M)	20 a
Diagnostic Coverage (DC)	0 %

Indicators/operating means

Function display	LED red
Controls	potentiometer , DIP-switch for selection of operating modes
Controls	sensitivity adjustment

Electrical specifications

Operating voltage	U _B	12 ... 36 V DC , 12 ... 28 V AC
No-load supply current	I ₀	≤ 50 mA at 24 V DC
Power consumption	P ₀	≤ 1.7 W

Output

Switching type	NO/NC	
Signal output	relay	
Switching voltage	max. 48 V AC / 48 V DC	
Switching current	max. 0.5 A AC / 1 A DC	
Switching power	max. 24 W / 60 VA	
De-energized delay	t _{off}	1 s

Ambient conditions

Operating temperature	-20 ... 60 °C (-4 ... 140 °F)
Storage temperature	-30 ... 70 °C (-22 ... 158 °F)
Relative humidity	max. 90 % non-condensing

Mechanical specifications

Mounting height	max. 4000 mm
Protection degree	IP54
Connection	Connecting cable 2.5 m included with delivery
Material	
Housing	black polycarbonate (PC)
Mass	130 g
Dimensions	101 mm x 60 mm x 59 mm

Suitable series

Series	RaDec
--------	-------

Compliance with standards and directives

Directive conformity	
R&TTE Directive 1995/5/EC	This device can be used in all countries within the European Union. Use in North America is not permitted. In other countries, all applicable national regulations must be observed.
Standard conformity	EN 62311, EN 60950-1, EN 301 489-1, EN 301 489-3, EN 300 440-2

Functional principle

Radar sensors are microwave sensors that adopt the principle of Doppler radar. The most important requirement for microwave detection is that the object to be detected is moving. Applications include controlling automatic doors and gates.

The sensor emits microwaves of a defined frequency in order to detect people and large objects moving at speeds between 100 mm/sec. and 5 m/sec. Stationary people or objects are not detected. Based on the latest 24 GHz technology with integrated microprocessor control, these sensors provide a high level of reliability, even in difficult operating conditions. The 24 GHz frequency, known as the 'K-band,' is reserved by CETECOM for this application area worldwide.

The direction detection function makes it possible to distinguish whether persons are moving towards the door or away from it. It is necessary to trigger the opening impulse if people are approaching the door. The sensor ignores objects that are moving away. Cross-traffic suppression serves a similar purpose. Automatic doors are often opened when a pedestrian walks too close to a shop window or a building facade. The cross-traffic suppression function can avoid this, because microwave technology combined with the microprocessor evaluation unit accurately detects these directions of motion. Both functions noticeably quiet the door area, increase the lifetime of the door mechanism, and in doing so help save energy.

Function

Typical applications

- Opening impulse sensors for automatic doors and industrial doors
- Monitoring approach areas to elevators
- Motion sensors for people and objects
- Impulse sensors for escalators

Detection area



Accessories

RaDec Weather Cap

Weather hood for radar sensors series RaDec

Other suitable accessories can be found at www.pepperl-fuchs.com

Release date: 2013-06-14 11:00 Date of issue: 2013-06-19 224402_eng.xml

Detection area

A wide or narrow detection area can be set by turning the PCB.

Detection area wide (Standard)

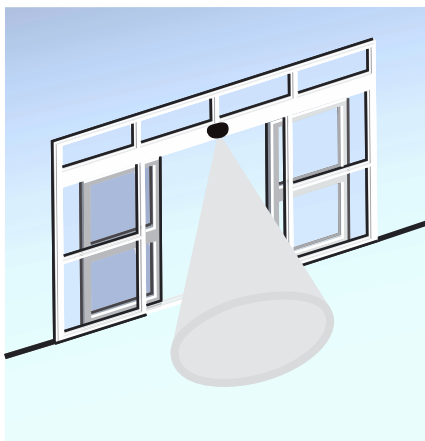

Detection area narrow

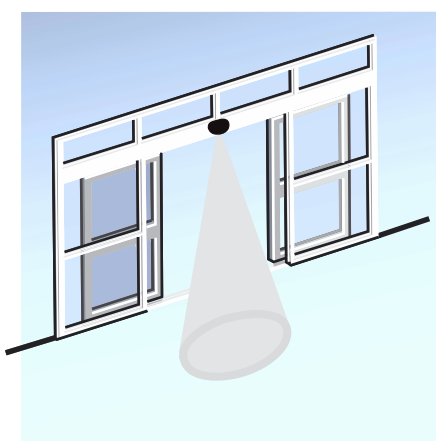

The size of the detection area can be changed using the potentiometer.

With the standard locking discs (already fitted in supplied device) you can set the position of the inclination angle in 10° or 5° increments from 0° to 90°.

By using the supplied locking discs for an inclined detection area (e. g. in revolving doors) the detection field can be rotated 15° left or right.

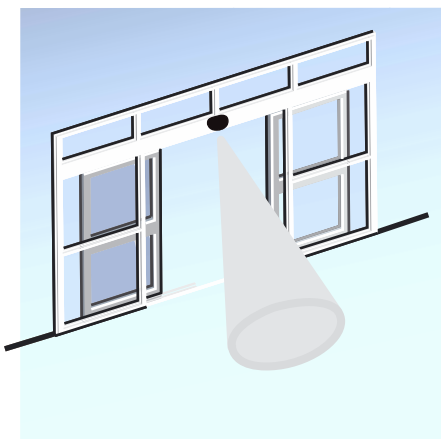

Detection capabilities

Direction detection

With direction detection, it can be set whether the sensor should be triggered by forward movements only or by forward and backward movements.

Cross-traffic suppression

Cross traffic suppression allows for passers-by to be partially suppressed.

Immunity

Immunity allows various external interferences, e.g. rain, vibrations and reflections to be minimized.

Relay contact switching mode

Relay contact when detection is active (NO)

Relay contact when detection is passive (NC)

The setting of the detection capabilities takes place with the DIP switch. The settings are checked by walking in the sensing area.

Release date: 2013-06-14 11:00 Date of issue: 2013-06-19 22:402_eng.xml