

Dimensions

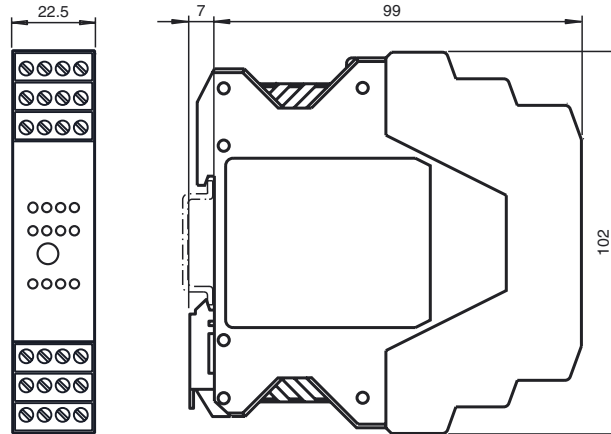

Electrical connection

Model number

VBA-4E-KE-ZEJQ

KE switch cabinet module
4 inputs (PNP)

Features

- Housing with removable and color coded terminals
- Communication monitoring
- Inputs for 2- and 3-wire sensors
- Addressing jack
- Selectable supply to the sensors: External or from the module
- Function display for bus, internal sensor supply, and inputs
- A/B slave with extended addressing possibility for up to 62 slaves

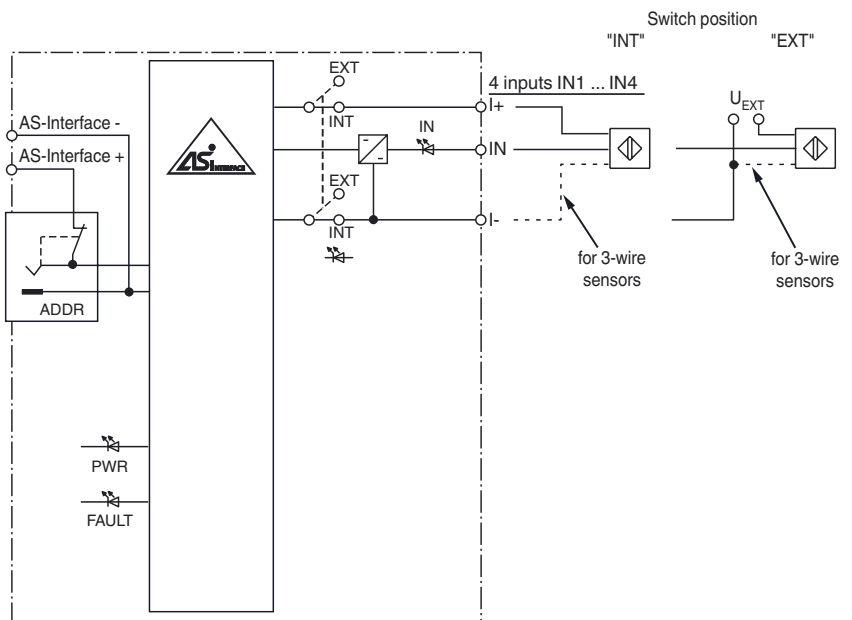

Indicating / Operating means

ATTENTION
Do not connect the terminals I+, IN and I- with any external potential when switch set to "INT"

Sensor supply:
INT = internal sensor supply (from AS-i)
EXT = external sensor supply

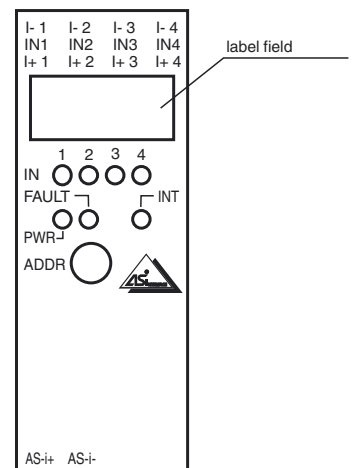
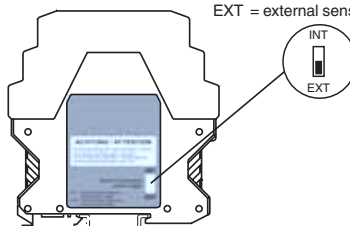

Release date: 2011-09-08 13:25 Date of issue: 2014-01-13 228631_Leng.xml

Technical data**General specifications**

Slave type	A/B slave
AS-Interface specification	V3.0
Required master specification	≥ V2.0
UL File Number	E87056

Indicators/operating means

LED FAULT	Fault display; Red LED red: Communication fault or address is 0 red, flashing: Overload, internal input supply
LED INT	Internal input supply active; LED green
LED PWR	AS-Interface voltage; green LED green: voltage OK flashing green: address 0
LED IN	switching state (input); 4 LED yellow

Electrical specifications

Auxiliary voltage (input)	U_{EXT}	12 ... 30 V DC PELV
Rated operating voltage	U_e	26.5 ... 31.6 V from AS-Interface
Rated operating current	I_e	≤ 30 mA (without sensors) / max. 180 mA
Protection class		III
Surge protection	U_{EXT} , U_e	Over voltage category III, safe isolated power supplies (PELV)

Input

Number/Type	4 inputs for 2- or 3-wire sensors (PNP), DC
Supply	from AS-Interface (switch position INT, basic setting) or external U_{EXT} (switch position EXT)
Voltage	21 ... 31 V DC (INT)
Current loading capacity	≤ 150 mA, overload- and short-circuit protected (INT)
Input current	≤ 9 mA (limited internally)
Switching point	according to DIN EN 61131-2 (Type 2)
0 (unattenuated)	≤ 3 mA
1 (attenuated)	≥ 5 mA
Signal delay	< 1 ms (input/AS-Interface)

Programming instructions

Profile	S-0.A.0
IO code	0
ID code	A
ID1 code	7
ID2 code	0

Data bits (function via AS-Interface)	input	output
D0	IN1	
D1	IN2	
D2	IN3	
D3	IN4	

Parameter bits (programmable via AS-i) function

P0	not used
P1	Input filter P1 = 0 input filter on, pulse suppression ≤ 2 ms P1 = 1 input filter off (basic setting)
P2	Synchronous mode P2 = 0 synchronous mode on P2 = 1 synchronous mode off (basic setting)
P3	not used

Ambient conditions

Ambient temperature	-25 ... 60 °C (-13 ... 140 °F)
Storage temperature	-25 ... 85 °C (-13 ... 185 °F)
Relative humidity	90 % , noncondensing
Pollution Degree	2

Mechanical specifications

Protection degree	IP20
Connection	removable terminals rated connection capacity: rigid/flexible (with and without wire-end ferrules): 0.25 mm ² ... 2.5 mm ² for multiple-wire connection with two wires of equal cross-section: flexible with twin wire-end ferrules: 0.5 mm ² ... 1.5 mm ²
Material	
Housing	PA 66-FR
Mass	150 g
Mounting	DIN mounting rail

Compliance with standards and directives

Directive conformity	
EMC Directive 2004/108/EC	EN 61000-6-2:2005, EN 61000-6-4:2007, EN 50295:1999
Standard conformity	
Noise immunity	EN 61000-6-2:2005, EN 61326-1:2006, EN 50295:1999
Emitted interference	EN 61000-6-4:2007

Function

The AS-Interface I/O module VBA-4E-KE-ZEJQ is a control cabinet module with 4 inputs. The housing is only 22.5 mm wide and takes up little space in the control cabinet. The module is mounted by snapping onto the 35-mm DIN rail in compliance with EN 50022.

The connection is made via plug-in terminals. Four-terminal blocks (black) are used for the inputs. The connection of AS Interface is via a 2-terminal block yellow.

The supply to the inputs and the connected sensors can be fed either from the internal supply of the module (from the AS-Interface) or via an external voltage source. A switch located on the side of the module changes the supply source. The choice of internal input supply is displayed via the LED INT. The LED IN display the current switching status of the relevant inputs.

Note:

Filters that suppress pulses with a duration of 2 ms or less at the inputs can be connected via the parameter P1.

Parameter P2 activates the synchronous mode. A signal indicating an overload of the internal input supply is transmitted to the AS-Interface master via the 'peripheral fault' function. Communication via the AS-Interface continues even if a peripheral fault is set.

Accessories**VBP-HH1-V3.0-KIT**

AS-Interface Handheld with accessory

VBP-HH1-V3.0

AS-Interface Handheld

VAZ-PK-1,5M-V1-G

Adapter cable module/hand-held programming device

Input	EN 61131-2:2004
Protection degree	EN 60529:2000
Fieldbus standard	EN 50295:1999, IEC 62026-2:2006

Notes

Do not connect inputs and outputs, which are supplied via the module from AS-interface or via auxiliary power, with power supply and signal circuits with external potentials.