

**Features**

- 1-channel signal conditioner
- 24 V DC supply (Power Rail)
- Input 2-wire and 3-wire transmitters and 2-wire current sources
- Signal splitter (1 input and 2 outputs)
- Dual output 0/4 mA ... 20 mA
- Accuracy 0.1 %
- Up to SIL3 acc. to IEC 61508

**Function**

This signal conditioner provides the isolation for non-intrinsically safe applications.

The device supplies 2-wire and 3-wire transmitters, and can also be used with 2-wire current sources.

It transfers the analog input signal as two isolated current values.

Both outputs provide a 0/4 mA ... 20 mA current corresponding to the input signal. The minimum available field voltage is 16 V at 20 mA.

If necessary, the internal resistance of 250 Ω between terminals 8, 9 and 11, 12 can be used for conversion into a 0 V ... 5 V voltage signal.

**Assembly**

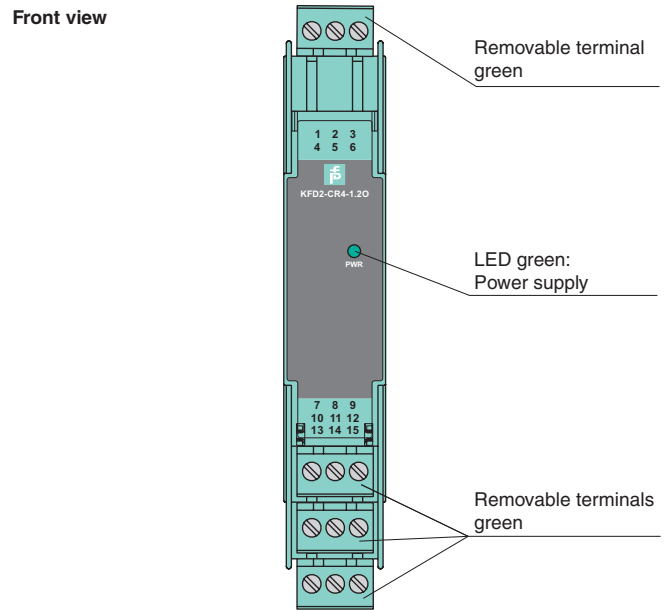

CE

SIL3

**Connection**

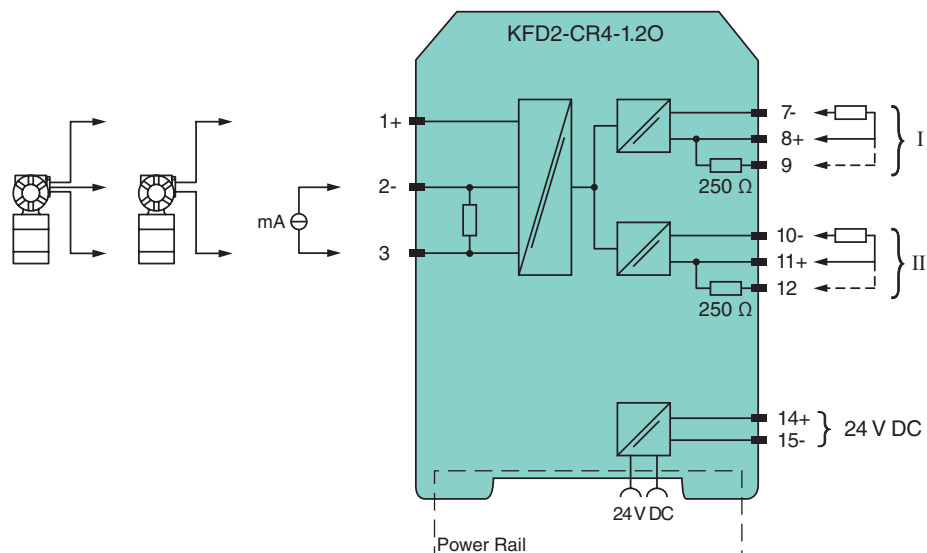

Release date 2013-08-07 15:41 Date of issue 2015-02-16 228758\_eng.xml

<b>General specifications</b>	
Signal type	Analog input
<b>Supply</b>	
Connection	Power Rail or terminals 14+, 15-
Rated voltage $U_n$	20 ... 32 V DC
Ripple	within the supply tolerance
Power loss	1.8 W
Power consumption	2.4 W
<b>Input</b>	
Connection	terminals 1, 2, 3
Input signal	0/4 ... 20 mA
Open circuit voltage/short-circuit current	terminals 1+, 3-: 22.7 V / 38 mA
Input resistance	terminals 2-, 3: $\leq 85 \Omega$
Available voltage	terminals 1+, 3: $\geq 16 V$ at 20 mA
Ripple	50 mV <sub>ss</sub> at 20 mA
<b>Output</b>	
Connection	terminals 7-, 8+,9; 10-, 11+,12
Load	0 ... 550 $\Omega$
Output signal	0/4 ... 20 mA
Ripple	$\leq 50 \mu A_{rms}$
<b>Transfer characteristics</b>	
Deviation	at 20 °C (68 °F), 0/4 ... 20 mA $\leq 10 \mu A$ incl. calibration, linearity, hysteresis, loads and fluctuations of supply voltage
Influence of ambient temperature	0.25 $\mu A/K$
Rise time	20 $\mu s$
Settling time	200 $\mu s$
De-energized delay	20 $\mu s$
<b>Electrical isolation</b>	
Input/Output	basic insulation according to IEC 61010-1, rated insulation voltage 300 V <sub>eff</sub>
Input/power supply	basic insulation according to IEC 61010-1, rated insulation voltage 300 V <sub>eff</sub>
Output/power supply	functional insulation, rated insulation voltage 50 V AC
Output/Output	functional insulation, rated insulation voltage 50 V AC
<b>Directive conformity</b>	
Electromagnetic compatibility	
Directive 2004/108/EC	EN 61326-1:2006
<b>Conformity</b>	
Electromagnetic compatibility	NE 21:2011
Degree of protection	IEC 60529:2001
Protection against electrical shock	EN 61010-1:2010
<b>Ambient conditions</b>	
Ambient temperature	-20 ... 60 °C (-4 ... 140 °F)
<b>Mechanical specifications</b>	
Degree of protection	IP20
Mass	approx. 150 g
Dimensions	20 x 119 x 115 mm (0.8 x 4.7 x 4.5 in) , housing type B2
Mounting	on 35 mm DIN mounting rail acc. to EN 60715:2001
<b>General information</b>	
Note	Both output loads must be connected to ensure complete and correct operation within the technical specification.
Supplementary information	Statement of Conformity, Declaration of Conformity, Attestation of Conformity and instructions have to be observed where applicable. For information see <a href="http://www.pepperl-fuchs.com">www.pepperl-fuchs.com</a> .

### Configuration active output (source)

If only one output of the two outputs is used, a jumper have to be set as follows.

Release date 2013-08-07 15:41 Date of issue 2015-02-16 228758\_eng.xml

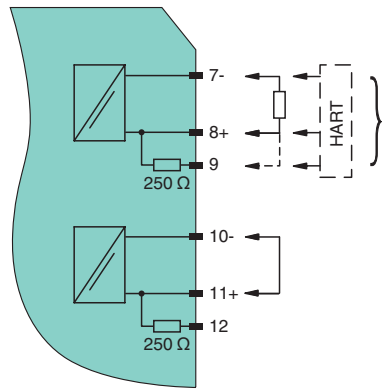

**Accessories**

**Power feed module KFD2-EB2**

The power feed module is used to supply the devices with 24 V DC via the Power Rail. The fuse-protected power feed module can supply up to 150 individual devices depending on the power consumption of the devices. Collective error messages received from the Power Rail activate a galvanically-isolated mechanical contact.

**Power Rail UPR-03**

The Power Rail UPR-03 is a complete unit consisting of the electrical insert and an aluminium profile rail 35 mm x 15 mm. To make electrical contact, the devices are simply engaged.

**Profile Rail K-DUCT with Power Rail**

The profile rail K-DUCT is an aluminum profile rail with Power Rail insert and two integral cable ducts for system and field cables. Due to this assembly no additional cable guides are necessary.



*Power Rail and Profile Rail must not be fed via the device terminals of the individual devices!*