

**Model Number**

**VOS412-BIS-60-WH-F119-4971**

Sheet inspection sensor for monitoring print by comparing stored images or barcode evaluation, right angle version

**Features**

- Automatic learning of the reference image
- Automatic search for optimum image section
- Integrated error image memory
- Integrated illumination
- Reliable detection at object speeds up to 4 m/s

**Function**

The sheet identification sensor from Pepperl+Fuchs enables fast and simple monitoring of the correct sheet sequence in collating, folding and binding machines. Sheets can be monitored either by using the image comparison method or reading in barcodes printed on the sheets.

The device can be operated locally, as a stand-alone unit or in a network where several sensors are connected together. The sensor includes a camera, illumination unit and evaluating computer with digital input and output signals as well as a network interface.

Typical areas of application are:

- Printing machines
- Folding machines
- Tying machines

**Indicating / Operating means**

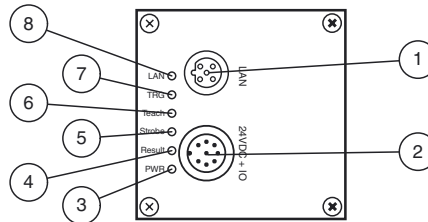

1	Socket LAN	
2	Plug 24VDC + IO	
3	Power	green
4	Result	green
5	Strobe	yellow
6	Teach	yellow
7	Trigger	yellow
8	LAN	yellow

**Electrical connection**

**LAN**



Pin	Signal
1	TX+ Ethernet
2	RX+ Ethernet
3	TX- Ethernet
4	RX- Ethernet

**24 V DC + I/O**

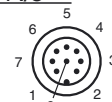

Pin	Signal
1	IN Encoder
2	+UB
3	OUT Result
4	OUT Strobe
5	IN Teach
6	IN TRG
7	GND
8	OUT Mode

**Technical data****General specifications**

Light type	Integrated LED lightning (white)
Object size	25 mm x 25 mm
Read distance	60 mm
Depth of focus	± 5 mm
Reading field	75 mm x 45 mm
Evaluation frequency	7 Hz
Target velocity	triggered ≤ 4 m/s

**Indicators/operating means**

Operating display	LED green: Ready for operation
-------------------	--------------------------------

**Electrical specifications**

Operating voltage	$U_B$	24 V DC ± 20 %
No-load supply current	$I_0$	max. 250 mA
Power consumption	$P_0$	6 W

**Interface 1**

Interface type	Ethernet
Protocol	TCP/IP
Transfer rate	100 MBit/s
Cable length	max. 30 m

**Input**

Input voltage	to be applied externally 24 V ± 15% PELV
Number/Type	2
Input current	approx. 3.5 mA at 24 V DC
Cable length	max. 30 m

**Output**

Number/Type	3 electronic outputs, PNP optically decoupled
Switching type	PNP optically decoupled , short-circuit/overload protected
Switching voltage	24 V
Switching current	max. 100 mA each output
Cable length	max. 30 m

**Ambient conditions**

Ambient temperature	0 ... 45 °C (32 ... 113 °F)
Storage temperature	-20 ... 60 °C (-4 ... 140 °F)

**Mechanical specifications**

Protection degree	IP65
Connection	M12 connector, 8-pin , 4-pin M12 socket
Material	
Housing	powder coated diecast zinc
Optical face	glass pane
Installation	2 x Threading M5
Mass	approx. 730 g

**Compliance with standards and directives**

Standard conformity	
Standards	EN 61326-1

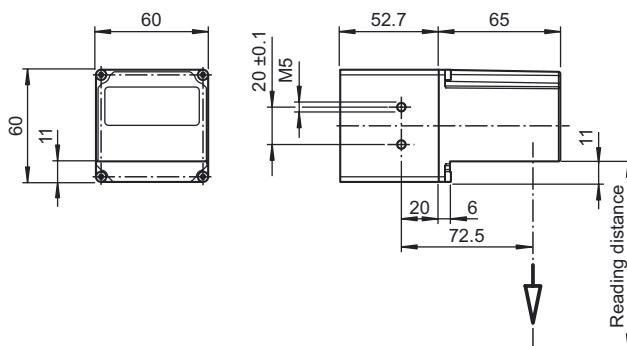
**Dimensions****Accessories****V1S-G**

Male cordset, M12, 4-pin, field attachable

**V1SD-G-2M-PUR-ABG-V45X-G**

Connection cable, M12 to RJ-45, PUR cable 4-pin, CAT5e

**V1SD-G-2M-PUR-ABG-V45-G**

Connection cable, M12 to RJ-45, PUR cable 4-pin, CAT5e

**V19-G-ABG-PG9**

Cable socket, M12, 8-pin, shielded, non pre-wired

**V19-G-2M-PUR-ABG**

Cable socket, M12, 8-pin, shielded, PUR cable

**BIS-VISUALIZER**

User-Interface "BIS Visualiser" for image display and basic parameters of the BIS devices

Other suitable accessories can be found at [www.pepperl-fuchs.com](http://www.pepperl-fuchs.com)