

Features

- 2-channel isolated barrier
- Universal usage at different power supplies
- Dry contact or NAMUR inputs
- Input frequency 1 mHz ... 1 kHz
- Current output 0/4 mA ... 20 mA
- Relay and transistor output
- Start-up override
- Configurable by **PACTware** or keypad
- Line fault detection (LFD)

Function

This isolated barrier is used for intrinsic safety applications. It analyzes 2 digital signals (NAMUR sensor/mechanical contact) from a hazardous area and functions as a rotation direction indicator, slip monitor, frequency monitor or synchronization monitor.

Each proximity sensor or switch controls a passive transistor output. The 2 relay outputs indicate if the input signal is above or below the trip value or the rotational direction.

The analog output can be programmed to be proportional to the input frequency or slip differential.

The unit is easily programmed by the use of a keypad located on the front of the unit or with the **PACTware™** configuration software.

Line fault detection of the field current is indicated by a red LED.

For additional information, refer to the manual and www.pepperl-fuchs.com.

Assembly

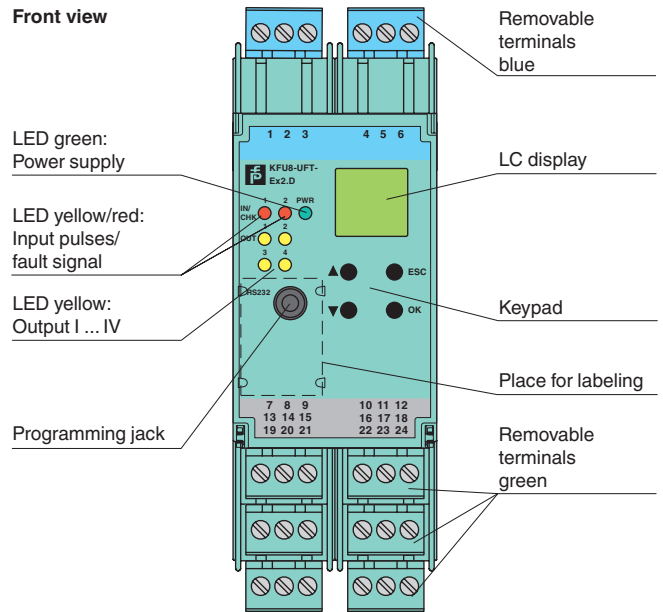

Connection

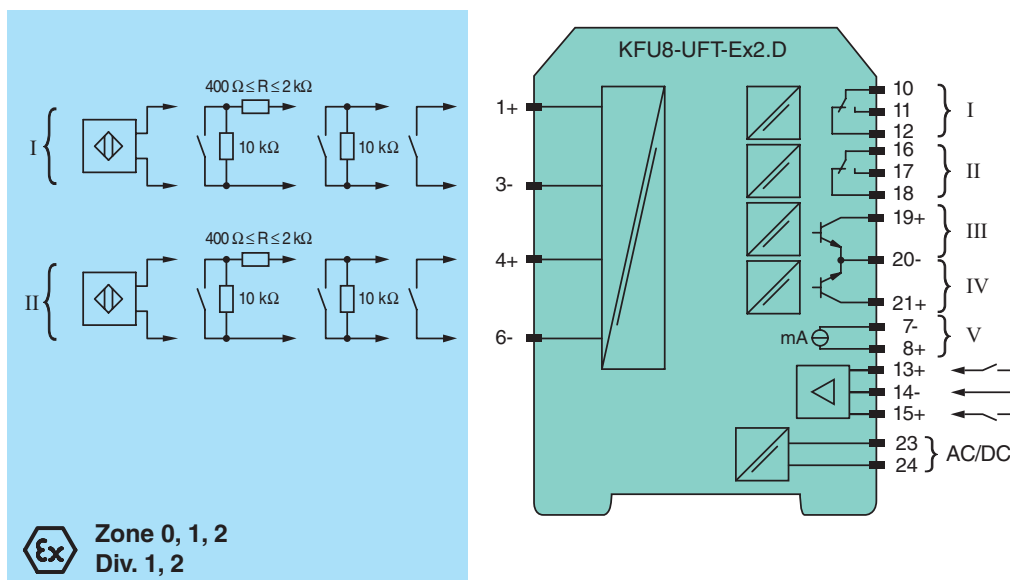

Release date 2014-08-19 09:56 Date of issue 2015-02-16 231202_eng.xml

Refer to "General Notes Relating to Pepperl+Fuchs Product Information".

Pepperl+Fuchs Group
www.pepperl-fuchs.com

USA: +1 330 486 0002
pa-info@us.pepperl-fuchs.com

Germany: +49 621 776 2222
pa-info@de.pepperl-fuchs.com

Singapore: +65 6779 9091
pa-info@sg.pepperl-fuchs.com

General specifications		
Signal type		Digital Input
Supply		
Connection		terminals 23, 24
Rated voltage	U_n	20 ... 90 V DC / 48 ... 253 V AC 50 ... 60 Hz
Rated current	I_n	approx. 130 mA
Power loss		2.2 W / 3.5 VA
Power consumption		2.5 W / 5 VA
Input		
Connection		input I: terminals 1+, 3- input II: terminals 4+, 6- input III: terminals 13+, 14- (control input 1) input IV: terminals 15+, 14- (control input 2)
Input III, IV		
Active/Passive		$I > 4 \text{ mA}$ (for min. 100 ms) / $I < 1.5 \text{ mA}$
Open circuit voltage/short-circuit current		18 V / 5 mA
Output		
Connection		output I: terminals 10, 11, 12 output II: terminals 16, 17, 18 output III: terminals 19+, 20- output IV: terminals 21+, 20- output V: terminals 7-, 8+
Output I, II		
Output I, II		signal , relay
Contact loading		250 V AC / 2 A / $\cos \phi \geq 0.7$; 40 V DC / 2 A
Mechanical life		5×10^7 switching cycles
Energized/De-energized delay		approx. 20 ms / approx. 20 ms
Output III and IV		
Output III and IV		signal , electronic output, passive
Contact loading		40 V DC
Signal level		1-signal: (L+) -2.5 V (50 mA, short-circuit/overload proof) 0-signal: switched off (off-state current $\leq 10 \mu\text{A}$)
Output V		
Output V		analog
Current range		0 ... 20 mA or 4 ... 20 mA
Open loop voltage		max. 24 V DC
Load		max. 650 Ω
Fault signal		downscale $I \leq 3.6 \text{ mA}$, upscale $I \geq 21.5 \text{ mA}$ (acc. NAMUR NE43)
Programming interface		
Connection		programming socket
Interface		RS 232
Transfer characteristics		
Input I and II		
Measurement range		0.001 ... 1000 Hz
Resolution		slip monitoring: 1% frequency measurement: 0,1% of measured value; but $>0.001\text{Hz}$
Accuracy		slip monitoring: 1% frequency measurement: 0.5% of measured value; but $>0.001\text{Hz}$
Measuring time		frequency measurement: $< 100 \text{ ms}$
Influence of ambient temperature		0.003 %/K (30 ppm)
Output I, II		
Response delay		$\leq 200 \text{ ms}$
Output V		
Resolution		$< 10 \mu\text{A}$
Accuracy		$< 30 \mu\text{A}$
Influence of ambient temperature		0.005 %/K (50 ppm)
Electrical isolation		
Input I, II/other circuits		reinforced insulation according to IEC/EN 61010-1, rated insulation voltage 300 V_{eff}
Input III, IV/power supply		reinforced insulation according to IEC/EN 61010-1, rated insulation voltage 300 V_{eff}
Output I, II/other circuits		reinforced insulation according to IEC/EN 61010-1, rated insulation voltage 300 V_{eff}
Mutual output I, II, III		reinforced insulation according to IEC/EN 61010-1, rated insulation voltage 300 V_{eff}
Mutual output I, II, IV		reinforced insulation according to IEC/EN 61010-1, rated insulation voltage 300 V_{eff}
Output III, IV/power supply		reinforced insulation according to IEC/EN 61010-1, rated insulation voltage 300 V_{eff}
Output III, IV/input III, IV		basic insulation according to IEC/EN 61010-1, rated insulation voltage 50 V_{eff}
Output III, IV/V		basic insulation according to IEC/EN 61010-1, rated insulation voltage 50 V_{eff}
Output V/power supply		reinforced insulation according to IEC/EN 61010-1, rated insulation voltage 300 V_{eff}
Interface/power supply		reinforced insulation according to IEC/EN 61010-1, rated insulation voltage 300 V_{eff}
Interface/output III, IV		basic insulation according to IEC/EN 61010-1, rated insulation voltage 50 V_{eff}
Directive conformity		
Electromagnetic compatibility		

Release date 2014-08-19 09:56 Date of issue 2015-02-16 231202_eng.xml

Refer to "General Notes Relating to Pepperl+Fuchs Product Information".

Pepperl+Fuchs Group
www.pepperl-fuchs.com

USA: +1 330 486 0002
pa-info@us.pepperl-fuchs.com

Germany: +49 621 776 2222
pa-info@de.pepperl-fuchs.com

Singapore: +65 6779 9091
pa-info@sg.pepperl-fuchs.com

Directive 2004/108/EC	EN 61326-1:2006
Low voltage	
Directive 2006/95/EC	EN 61010-1:2010
Conformity	
Electromagnetic compatibility	NE 21:2006
Degree of protection	IEC 60529:2001
Input	EN 60947-5-6:2000
Ambient conditions	
Ambient temperature	-20 ... 60 °C (-4 ... 140 °F)
Mechanical specifications	
Degree of protection	IP20
Mass	300 g
Dimensions	40 x 119 x 115 mm (1.6 x 4.7 x 4.5 in) , housing type C3
Mounting	on 35 mm DIN mounting rail acc. to EN 60715:2001
Data for application in connection with Ex-areas	
EC-Type Examination Certificate	TÜV 99 ATEX 1471 , for additional certificates see www.pepperl-fuchs.com
Group, category, type of protection	⊕ II (1)GD, I (M1) [Ex ia] IIC, [Ex iaD], [Ex ia] I (-20 °C ≤ T _{amb} ≤ 60 °C)
Supply	
Maximum safe voltage U _m	253 V AC / 125 V DC (Attention! U _m is no rated voltage.)
Input I and II	terminals 1+, 3-, 4+, 6- Ex ia IIC, Ex iaD
Voltage U _o	10.1 V
Current I _o	13.5 mA
Power P _o	34 mW (linear characteristic)
Input III and IV	terminals 13+, 14-, 15+, 14- non-intrinsically safe
Maximum safe voltage U _m	40 V (Attention! U _m is no rated voltage.)
Output I, II	terminals 10, 11, 12; 16, 17, 18 non-intrinsically safe
Maximum safe voltage U _m	253 V (Attention! The rated voltage can be lower.)
Contact loading	253 V AC/2 A/cos φ > 0.7; 40 V DC/2 A resistive load (TÜV 99 ATEX 1471)
Output III and IV	terminals 19, 20, 21 non-intrinsically safe
Maximum safe voltage U _m U _m	40 V (Attention! U _m is no rated voltage.)
Output V	terminals 8+, 7- non-intrinsically safe
Maximum safe voltage U _m U _m	40 V DC (Attention! U _m is no rated voltage.)
Interface	RS 232
Maximum safe voltage U _m	40 V (Attention! U _m is no rated voltage.)
Electrical isolation	
Input I, II/other circuits	safe electrical isolation acc. to IEC/EN 60079-11, voltage peak value 375 V
Directive conformity	
Directive 94/9/EC	EN 60079-0:2012 , EN 60079-11:2012 , EN 60079-15:2010 , EN 60079-26:2007
International approvals	
FM approval	
Control drawing	16-538FM-12
General information	
Supplementary information	EC-Type Examination Certificate, Statement of Conformity, Declaration of Conformity, Attestation of Conformity and instructions have to be observed where applicable. For information see www.pepperl-fuchs.com .

Release date 2014-08-19 09:56 Date of issue 2015-02-16 231202_eng.xml

Refer to "General Notes Relating to Pepperl+Fuchs Product Information".

Pepperl+Fuchs Group
www.pepperl-fuchs.com

USA: +1 330 486 0002
pa-info@us.pepperl-fuchs.com

Germany: +49 621 776 2222
pa-info@de.pepperl-fuchs.com

Singapore: +65 6779 9091
pa-info@sg.pepperl-fuchs.com

Function

The device processes two input frequencies up to a max. of 1 kHz. The following functions are provided by the device:

- Frequency measurement with freely adjustable trip value monitoring for high and low alarm as well as for frequency-current-conversion (0/4 mA ... 20 mA)
- Slip monitoring: The slip is calculated from the two input frequencies at channel I and II. If the freely parameterisable trip value is exceeded, the respective output switches.
- Rotation direction signalling: The rotation direction is evaluated from the two input signals with the same frequency and a phase shift of 90°. The corresponding outputs switch according to the direction of rotation.
- The frequency monitoring can be used in combination with rotation direction signalling or slip monitoring.
- Synchronisation monitor: The synchronisation monitor compares the pulse counts of the two inputs. If the measured difference in the pulses is greater than the programmed value the corresponding outputs are switching.

The two electronic outputs serve to repeat the input signals.

Accessories

PACT*ware*TM

Device-specific drivers (DTM)

Adapter K-ADP1

Programming adapter for parameterisation via the serial RS 232 interface of a PC/Notebook

For programming, please use the new version of adapter K-ADP1 (part no. 181953, connector length 14mm). When using the previous version K-ADP1 (connector length 18 mm) the plug is exposed by approx. 3 mm. The function is not affected.

Adapter K-ADP-USB

Programming adapter for parameterisation via the serial USB interface of a PC/Notebook