



Model Number

UC1500-F65-FE2R2-V15

Features

- Level indication
- Frequency output
- Programmable by means of Interface (see accessories) and SON-PROG
- Synchronization options
- Temperature compensation

Diagrams

Characteristic response curve

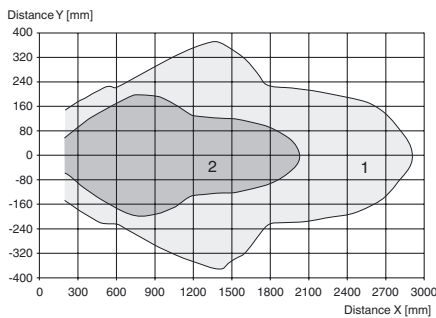

Curve 1: flat surface 100 mm x 100 mm
Curve 2: round bar, Ø 25 mm

Technical data

General specifications

Sensing range	200 ... 1500 mm
Adjustment range	200 ... 1500 mm
Unusable area	0 ... 200 mm
Standard target plate	20 mm x 20 mm
Transducer frequency	approx. 200 kHz

Nominal ratings

Time delay before availability t_v	250 ms
--------------------------------------	--------

Limit data

Permissible cable length	max. 300 m
--------------------------	------------

Indicators/operating means

LED green	Power on
LED yellow	solid: switching state switch output flashing: misadjustment

Electrical specifications

Rated operating voltage U_e	24 V DC
Operating voltage U_B	12 ... 30 V (including ripple) In supply voltage interval 12 ... 20 V reduced sensitivity by 20% ... 0%
Ripple	≤ 10 %
No-load supply current I_0	≤ 60 mA

Input

Input type	1 Function input
Input voltage	≤ Operating voltage
Level	low level : 0 ... 3 V high level : ≥ 15 V

Output

Output type	1 Frequency output
Rated operating current I_e	300 mA
Default setting	200 mm ... 1500 mm
Linearity	≤ 1.5 %
Output frequency	20 ... 150 Hz (200 ... 1500 Hz) , adjustable

Ambient conditions

Ambient temperature	-25 ... 70 °C (-13 ... 158 °F)
Storage temperature	-40 ... 85 °C (-40 ... 185 °F)
Shock resistance	30 g , 11 ms period
Vibration resistance	10 ... 55 Hz , Amplitude ± 1 mm

Mechanical specifications

Connection type	Connector M12 x 1 , 4-pin
Protection degree	IP65
Material	
Housing	PBT
Transducer	epoxy resin/hollow glass sphere mixture; polyurethane foam
Installation position	any position
Mass	500 g

Compliance with standards and directives

Standard conformity	
Standards	EN 60947-5-2:2007 IEC 60947-5-2:2007

Approvals and certificates

UL approval	cULus Listed, General Purpose
CSA approval	cCSAus Listed, General Purpose
CCC approval	CCC approval / marking not required for products rated ≤36 V

Release date: 2012-07-12 14:43 Date of issue: 2013-10-25 235151_eng.xml

Dimensions

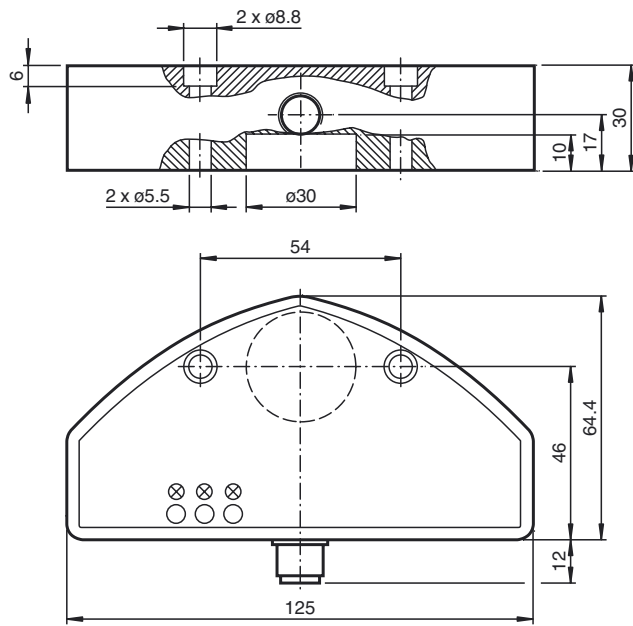

Electrical Connection

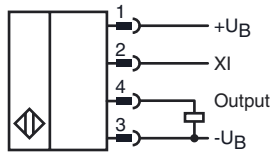

Pinout

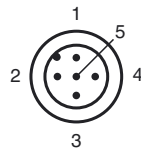

Wire colors in accordance with EN 60947-5-2

1	BN	(brown)
2	WH	(white)
3	BU	(blue)
4	BK	(black)
5	GY	(gray)

Additional Information

Function of the output

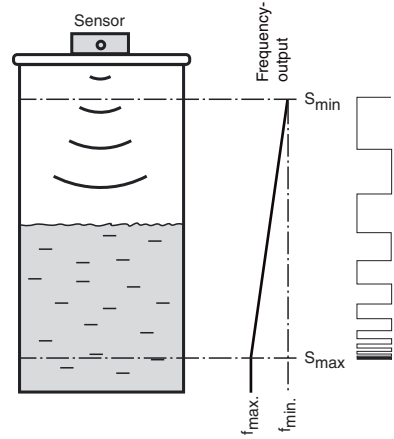

Accessories

V1-G-2M-PUR

Female cordset, M12, 4-pin, PUR cable

V1-G-2M-PVC

Female cordset, M12, 4-pin, PVC cable

V1-W-2M-PUR

Female cordset, M12, 4-pin, PUR cable

V1-W-2M-PVC

Female cordset, M12, 4-pin, PVC cable

3RX4000-PF

PC interface

Application ranges

The design and function of this ultrasonic sensor make it ideal for filling level applications in small containers. The device has a frequency output. The frequency of the output signal is a measure of the current filling level.

Assembly and connection

All components are contained in an encapsulated housing. The ultrasonic converter is in a slightly recessed position in the housing. The integrated circumferential seal allows the sensor to be used directly as a closure with integrated filling level measurement. The tank opening must have a diameter of 26 mm. It can be mounted on the tank using 2 M5 screws. The electrical connection is based on a 5-pin device connector, M12 x 1. The connections are protected against reverse polarity, short circuits and overloads. Shielded cables are recommended if there is electrical interference.

Setting

As delivered, the measuring range limits and the averaging are fixed (see Technical data). They can subsequently be adapted to the application via SONPROG using the interface (see Accessories).

SONPROG

The following parameters can be changed via SONPROG:

- Measuring range limits S_{min} and S_{max}
- Frequency range
- Blind zone
- Averaging

Special programming options are available on request.

Operation

The filling level of a container is detected within the detection range. Filling levels between the measuring range limits (S_{min} , S_{max}) are displayed in the form of a rectangular signal with variable frequency. The frequency output delivers the smallest frequency value at filling level S_{min} and the highest frequency at filling level S_{max} . The frequency characteristic between the two measuring range limits is linear.

Objects in the blind zone cause false signals. Install in such a way that the filling level cannot enter the blind zone.

Function input XI

The sensor is placed in standby mode by connecting a low level at the function input XI. The sensors then performs no measurements. The outputs retain the most recent status. As soon as function input XI is disconnected from the low level or a high level is connected, the sensor resumes its normal function.

The function input XI can be used during operation for the synchronisation of multiple sensors. This can be done by connecting external signals, e.g. from a controller (external synchronisation) or by simply connecting the function inputs of all sensors to be synchronised (internal synchronisation).