



Model Number

Safe Speed Monitor

Features

- **Monitoring of safe standstill, safe speed, and safe direction of rotation**
- **User-friendly configuration via PC software**
- **Satisfies technical safety requirements to SIL 3/PL_e with just one safety rotary encoder per rotational axis**
- **Can be extended to max. 40 rotational axes**

Description

The *Safe Speed Monitor* meets all safety requirements up to SIL 3 / PL e. It is a modular system and consists in the basic configuration of a compact safety control, a speed monitor module and a safe sine/cosine encoder. To monitor the drive shaft(s) the system provides 2 safe outputs for the functions "safe standstill", "safe speed" and "safe acceleration / deceleration ramp". Monitoring for a second shaft is already integrated in the basic unit. The *Safe Speed Monitor* is also equipped with 4 safety inputs and is expandable up to 40 shafts.

Technical data

Functional safety related parameters

Safety Integrity Level (SIL)	SIL 3
Performance level (PL)	PL e
Mission Time (T _M)	20 a
PFH _d	7.85 E-9

Indicators/operating means

LED AS-i M	Status of AS interface master, multicolored LED green: Master OK
LED SM	Status of safety monitor, multicolored LED green: Safety monitor OK
LED FAULT	error display; LED red red: communication error
LED S1 ... S8	Status of inputs S1 ... S8, yellow LED yellow: Contact open
LED AS-i	AS-Interface voltage; LED green
LED AUX	ext. auxiliary voltage U _{AUX} ; LED green
LED CONF	Off = Normal mode, yellow LED
LED O1, O2	Status of outputs, multicolored LED yellow: Output on
LED STATE	Status of rotary encoder, 2 yellow LEDs
LED FREQUENCY	Low frequency or halt, 2 LED yellow

Electrical specifications

Rated operational current I _e	≤ 350 mA / ≤ 4 A off AUX
--	--------------------------

Interface 1

Interface type	Chip card slot
----------------	----------------

Interface 2

Interface type	Micro USB
----------------	-----------

Input

Number/Type	2 inputs for incremental rotary encoders AMP mini-IO connector
Signal delay	100 ms at 1015 Hz < f _{limit} 140 ms at 45 Hz < f _{limit} < 1015 Hz 700 ms at f _{limit} < 45 Hz
Signal frequency	Parameterization range 25 Hz ... 200 kHz

Output

Number/Type	Output circuits 1 and 2 max. contact rating: 700 m A _{DC-13} at 24 V
-------------	---

Ambient conditions

Ambient temperature	0 ... 55 °C (32 ... 131 °F)
---------------------	-----------------------------

Mechanical specifications

Protection degree	IP20
Connection	removable terminals

Material

Housing	PA 66-FR
Mounting	DIN rail

General information

Scope of delivery	1 AS-Interface safety module VAS/M-2A8L-KE4-8SE-C1 1 AS-Interface safety module VBA-2E-KE4-ENC-S
-------------------	---

Dimensions

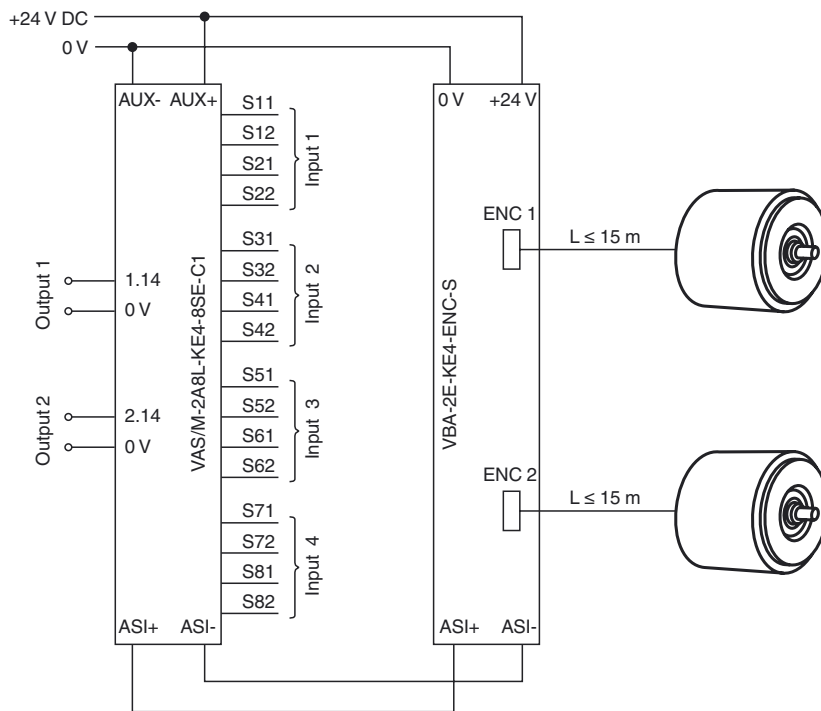
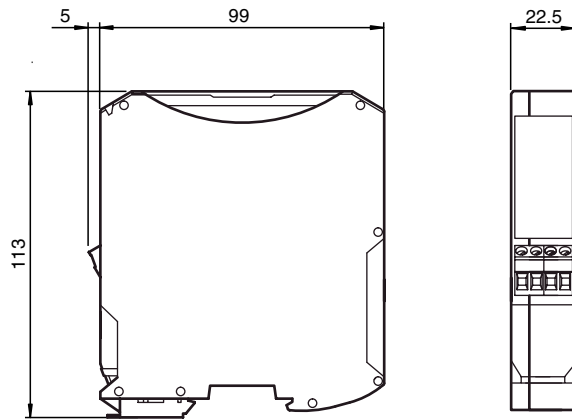
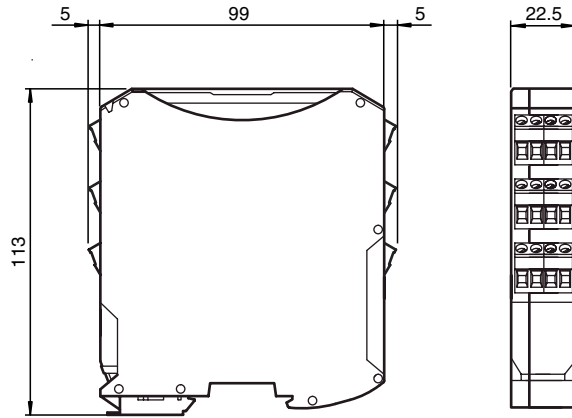

Release date: 2012-10-24 08:48 Date of issue: 2012-11-12 235505_eng.xml

Accessories

RVS58S-282YR4ZN-01024

safety incremental encoder

VAZ-SW-SIMON+

Software for configuration of K30 Master Monitors/K31 Safety Monitors

VAZ-ENC-1,5M-PVC

Connection cable for connecting encoders to a speed monitor

System description

The *Safe Speed Monitor* provides all the necessary safety functions while retaining existing conventional drive technology. This makes it ideal for plant refurbishments and retrofitting existing plants with safety functions. Using just a single rotary encoder per rotational axis, it satisfies all safety requirements to SIL 3/PL e. The effort and costs for redundant technology are therefore superfluous. You need neither an additional fail-safe PLC nor additional safety relays.

The system has a modular design. The simplest version comprises a compact safety control system, a rotation speed monitor module, and a safe sine/cosine rotary encoder with a 58 mm diameter and 1024 periods per revolution. Together with the integrated self-diagnostic capability, the latter forms the basis for the single-encoder solution. The device continuously verifies the plausibility of the encoder signals from the two tracks offset by 90 degrees. The supply voltage, temperature, LED activation, and checksum of the calibration data are also monitored.

Safe functions replace mechanical aids

To monitor the drive axis(es), the functions "safe standstill," "safe speed," and "safe direction of rotation" are available via two safe outputs. If one of the conditions is violated, e.g., the permissible speed is exceeded, the system immediately invokes the relevant countermeasures, such as an emergency stop. Numerous additional safety functions can be parameterized using the complete solution. These include emergency stop, stop categories 0 and 1, two-handed operation, door locking, external device monitoring, and restart interlock.

Parametrization without programming knowledge

The Safe Speed Monitor can be parameterized intuitively using PC software without special PLC programming knowledge. Keys enable the current speed to be conveniently programmed via the Teach-in procedure. The monitor offers options for both online and onsite diagnostics via LEDs. Machine documentation can be created automatically. Since the configurations are saved to a memory card, you can replace the programs at lightning speed, transfer to different hardware, or create a series of monitors with similar functionality. Standstills are minimized when replacing system components.

The monitor has four safe inputs that enable additional standard or safety peripherals to be connected directly to the device. The decentralized solution can be retrofitted with an impressive maximum expansion of 40 rotational axes by adding further rotation speed monitor modules. Monitoring for a second rotational axis is already integrated into the basic device. If necessary, the system can even be networked via com units with a superordinate fieldbus such as PROFINET or PROFIBUS-DP.

Economic and cost-efficient

With these attributes, the *Safe Speed Monitor* ensures cost efficiency and economy in many applications. The intelligent safety functions render numerous mechanical protective devices obsolete. They downsize protection areas, simplify set up mode, and reduce safety-related standstills. It is not always necessary to stop production to perform maintenance or retrofit work. Extending the requisite safety while retaining existing components and standard modules saves money and enables swift and uncomplicated proof of conformity.

Your benefits at a glance:

- Certified functional safety together with sin/cos rotary encoder
- Streamlined complete solution
- Optimum safety type with just one safety rotary encoder per rotational axis
- Monitoring of standstill, speed, and direction of rotation for two rotational axes, as well as additional safe inputs/outputs
- Integrated power supply for the rotary encoder
- Simplest modular modification/upgrade depending on the number of rotational axes with additional rotation speed monitor modules
- Affordable alternatives to expensive "safety integrated" drives
- Simple mounting as there are no redundant sensors, and only one rotary encoder is required
- Independent safety monitoring, separate from the application
 - no fail-safe PLC required
 - no change to the plant concept
 - established standard components retained
- Simple safety retrofit for existing machines
- Simplest component replacement without reparameterization via chip card

Indicators and operating means

SET = Service button
 CHIP CARD = Chip card

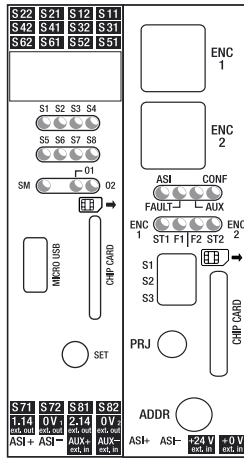

ENC 1 = Encoder 1
 ENC 2 = Encoder 2
 S1, S2, S3 = Function switch 1 ... 3
 CHIP CARD = Chip card
 PRJ = Configuration button
 ADDR = Addressing jack