

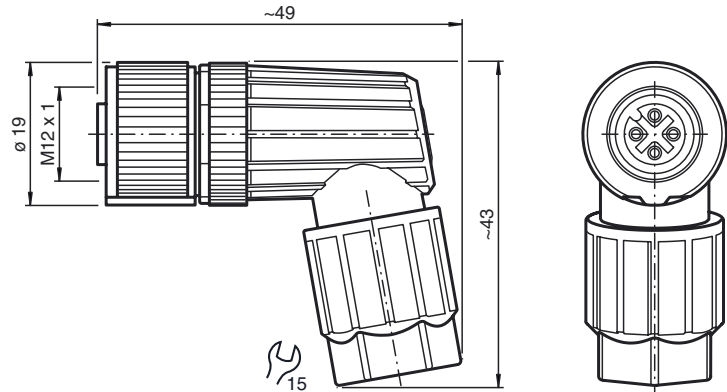

Dimensions



Model Number

V1-W-SC

Field attachable female cordset

Features

- Cage spring connection
- SPEEDCON technology

Technical data

General specifications

Number of pins	4
Connection 1	female connector
Construction type 1	right angle
Threading 1	M12

Electrical specifications

Operating voltage	U_B	max. 250 V AC/DC
Operating current		max. 4 A
Volume resistance		< 8 m Ω

Ambient conditions

Ambient temperature	-40 ... 85 °C (-40 ... 185 °F)
Pollution Degree	3

Mechanical specifications

Protection degree	IP67
Connection	1 x M12 right-angled socket Cage spring connection Conductor cross-section 0.14 ... 0.5 mm ² (26 ... 20 AWG)

Material

Contacts	CuSn
Contact surface	Ni/Au
Body	PA 66
Slotted nut	CuZn, nickel-plated
Seal	NBR

Cable

Sheath diameter	4 ... 8 mm
-----------------	------------

Electrical connection

