

Features

- 4-channel
- Inputs with plug-in Ex e terminals
- Power supply for 2-wire transmitters with 4 mA ... 20 mA
- Supply circuit 15 V (20 mA)
- Input from active signals of 4-wire transmitters
- Installation in suitable enclosures in Zone 1 or Zone 21
- HART communication via field bus or service bus
- Simulation mode for service operations (forcing)
- Line fault detection (LFD)
- Permanently self-monitoring
- Module can be exchanged under voltage (hot swap)

Function

The transmitter power supply feeds 2-wire transmitters. Active signals from separately powered field devices and 4-wire transmitters can be connected. Open and short-circuit line faults are detected. The device is supplied with plug-in Ex e terminals and protective cover. The input is galvanically isolated from the bus and the power supply.

Assembly

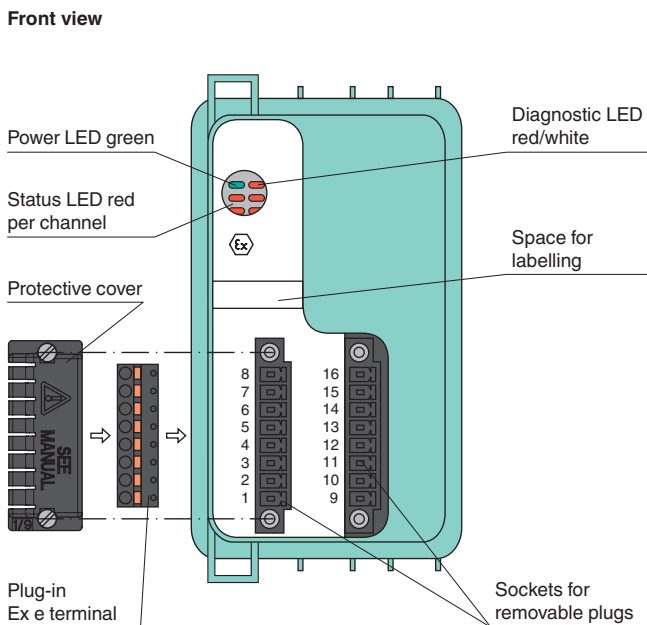

Connection

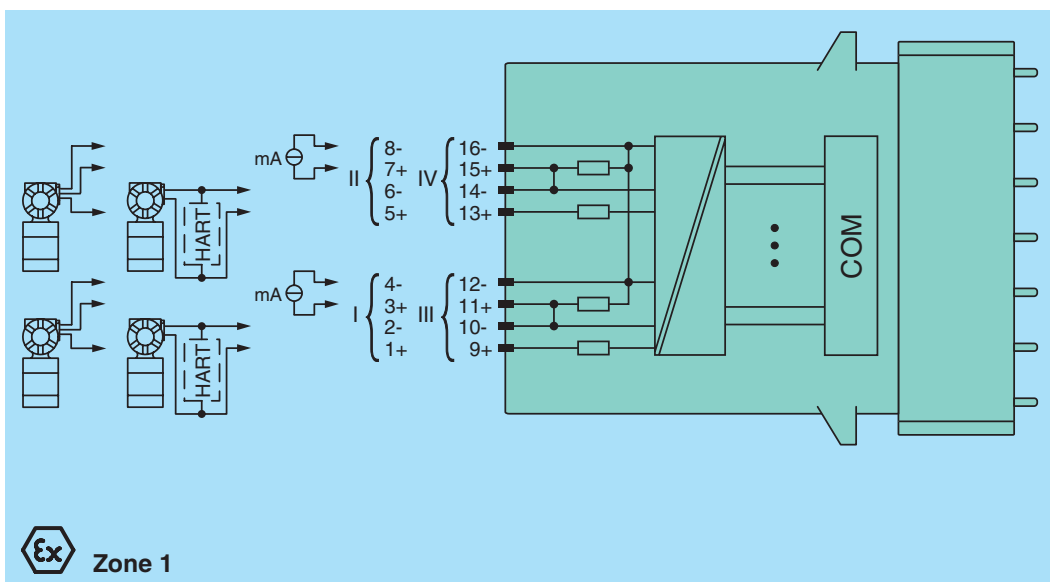

Release date 2015-03-24 14:00 Date of issue 2015-03-24 238487_eng.xml

Refer to "General Notes Relating to Pepperl+Fuchs Product Information".

Supply		
Connection		backplane bus
Rated voltage	U_n	12 V DC , only in connection with the power supplies FB92**
Power loss		1.5 W
Power consumption		3 W
Internal bus		
Connection		backplane bus
Interface		manufacturer-specific bus to standard com unit
Input		
Number of channels		4
Suitable field devices		transmitters for pressure, differential pressure, level, flow, temperature, etc.
Connection		2-wire transmitter (HART): supply circuit: channel I 1+, 2-, channel II 5+, 6-, channel III 9+, 10-, channel IV 13+, 14- 3-wire transmitter: supply circuit: channel I 1+, 4-, channel II 5+, 8-, channel III 9+, 12-, channel IV 13+, 16- measuring circuit: channel I 3+, 4-, channel II 7+, 8-, channel III 11+, 12-, channel IV 15+, 16- 4-wire transmitter (separately powered): measuring circuit: channel I 3+, 4-, channel II 7+, 8-, channel III 11+, 12-, channel IV 15+, 16-
Input resistance		15 Ω (channel I: 3, 4; channel II: 7, 8; channel III: 11, 12; channel IV: 15, 16)
Line fault detection		can be switched on/off for each channel via configuration tool , configurable via configuration tool
Short-circuit		Ex works settings: > 22 mA configurable between 0 ... 26 mA
Open-circuit		Ex works settings: < 1 mA configurable between 0 ... 26 mA
Transmitter supply voltage		15 V at 20 mA
Transfer characteristics		
Deviation		
After calibration		0.1 % of the signal range at 20 °C (68 °F)
Influence of ambient temperature		0.1 %/10 K of the signal range
Resolution		12 Bit (0 ... 26 mA)
Refresh time		100 ms
Indicators/settings		
LED indicator		Power LED (P) green: supply Diagnostic LED (I) red: module fault , red flashing: communication error , white: fixed parameter set (parameters from com unit are ignored) , white flashing: requests parameters from com unit Status LED (1-4) red: line fault (lead breakage or short circuit)
Coding		optional mechanical coding via front socket
Directive conformity		
Electromagnetic compatibility		
Directive 2004/108/EC		EN 61326-1:2006
Conformity		
Electromagnetic compatibility		
Degree of protection		IEC 60529:2000
Environmental test		EN 60068-2-14:2009
Shock resistance		EN 60068-2-27:2009
Vibration resistance		EN 60068-2-6:2008
Damaging gas		EN 60068-2-42:2003
Relative humidity		EN 60068-2-78:2001
Ambient conditions		
Ambient temperature		-20 ... 60 °C (-4 ... 140 °F)
Storage temperature		-25 ... 85 °C (-13 ... 185 °F)
Relative humidity		95 % non-condensing
Shock resistance		shock type I, shock duration 11 ms, shock amplitude 50 m/s ² , number of shock directions 6, number of shocks per direction 100
Vibration resistance		frequency range 5 ... 500 Hz, amplitude 5 ... 13.2 Hz \pm 1.5 mm, 13.2 ... 100 Hz 1g, sweep rate 1 octave/min, duration 10 sweeps 5 Hz - 100 Hz - 5 Hz
Damaging gas		for plugs: 21 days in 25 ppm SO ₂ , at 25 °C and 75 % rel. humidity, device G3
Mechanical specifications		
Degree of protection		IP20 (module) , a separate housing is required acc. to the system description
Connection		Ex e spring terminal with protective cover
Mass		approx. 750 g
Dimensions		57 x 107 x 132 mm (2.2 x 4.2 x 5.2 in)
Data for application in connection with Ex-areas		
EC-Type Examination Certificate		BVS 11 ATEX E 093 X , for additional certificates see www.pepperl-fuchs.com
Group, category, type of protection		 II 2 G Ex db eb IIC T4
Electrical isolation		
Input/power supply, internal bus		safe electrical isolation acc. to EN 60079-11:2007 , voltage peak value 375 V

Release date 2015-03-24 14:00 Date of issue 2015-03-24 238487_eng.xml

Refer to "General Notes Relating to Pepperl+Fuchs Product Information".

Directive conformity	
Directive 94/9/EC	EN 60079-0:2009 EN 60079-1:2007 EN 60079-7:2007
General information	
System information	The module has to be mounted in appropriate backplanes (FB92**) in Zone 1, 2, or outside hazardous areas. Here, the corresponding EC-Type Examination Certificate has to be observed.
Supplementary information	EC-Type Examination Certificate, Statement of Conformity, Declaration of Conformity, Attestation of Conformity and instructions have to be observed where applicable. For information see www.pepperl-fuchs.com .

Release date 2015-03-24 14:00 Date of issue 2015-03-24 238487_eng.xml

Refer to "General Notes Relating to Pepperl+Fuchs Product Information".

Pepperl+Fuchs Group
www.pepperl-fuchs.com

USA: +1 330 486 0002
pa-info@us.pepperl-fuchs.com

Germany: +49 621 776 2222
pa-info@de.pepperl-fuchs.com

Singapore: +65 6779 9091
pa-info@sg.pepperl-fuchs.com