

Features

- 4-channel
- Inputs Ex ia
- Power supply for 2-wire transmitters with 4 mA ... 20 mA
- Supply circuit 15 V (20 mA)
- Input from active signals of 4-wire transmitters
- Installation in Zone 2, Zone 22, Div. 2, or safe area
- Simulation mode for service operations (forcing)
- Line fault detection (LFD): one LED per channel
- Permanently self-monitoring
- Module can be exchanged under voltage

Function

The transmitter power supply feeds 2-wire transmitters. Active signals from separately powered field devices and 4-wire transmitters can be connected. Open and short-circuit line faults are detected. The intrinsically safe inputs are galvanically isolated from the bus and the power supply.

Assembly

Front view

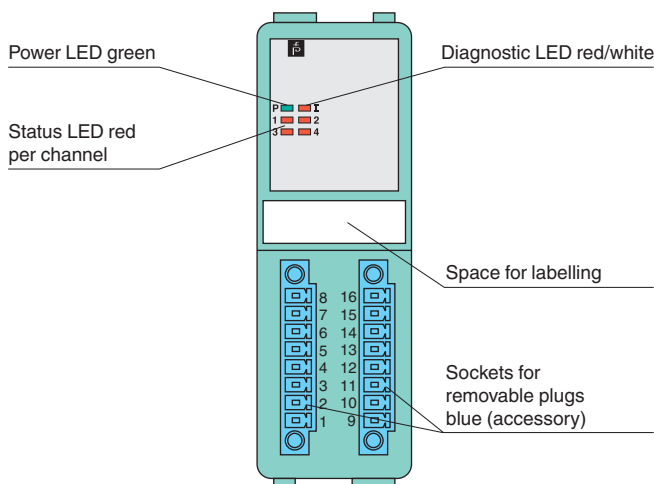

Connection

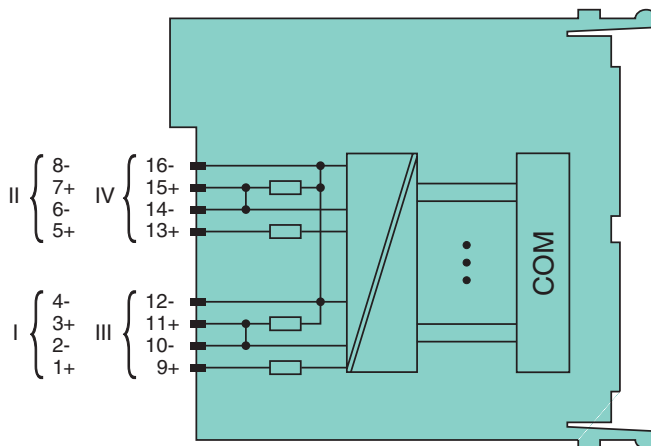
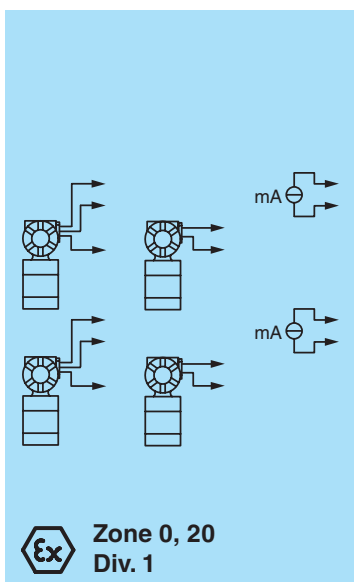

Zone 2 Div. 2

Release date 2015-03-10 13:36 Date of issue 2015-03-10 239076_eng.xml

Refer to "General Notes Relating to Pepperl+Fuchs Product Information".

Pepperl+Fuchs Group
www.pepperl-fuchs.com

USA: +1 330 486 0002
pa-info@us.pepperl-fuchs.com

Germany: +49 621 776 2222
pa-info@de.pepperl-fuchs.com

Singapore: +65 6779 9091
pa-info@sg.pepperl-fuchs.com

Supply		
Connection		backplane bus
Rated voltage	U _n	12 V DC , only in connection with the power supplies LB9***
Power loss		1.5 W
Power consumption		3 W
Internal bus		
Connection		backplane bus
Interface		manufacturer-specific bus to standard com unit
Input		
Number of channels		4
Suitable field devices		transmitters for pressure, differential pressure, level, flow, temperature, etc.
Connection		2-wire transmitter: supply circuit: channel I 1+, 2-, channel II 5+, 6-, channel III 9+, 10-, channel IV 13+, 14- 3-wire transmitter: supply circuit: channel I 1+, 4-, channel II 5+, 8-, channel III 9+, 12-, channel IV 13+, 16- measuring circuit: channel I 3+, 4-, channel II 7+, 8-, channel III 11+, 12-, channel IV 15+, 16- 4-wire transmitter (separately powered): measuring circuit: channel I 3+, 4-, channel II 7+, 8-, channel III 11+, 12-, channel IV 15+, 16-
Input resistance		15 Ω (channel I: 3, 4; channel II: 7, 8; channel III: 11, 12; channel IV: 15, 16)
Line fault detection		can be switched on/off for each channel via configuration tool , configurable via configuration tool
Short-circuit		Ex works settings: > 22 mA configurable between 0 ... 26 mA
Open-circuit		Ex works settings: < 1 mA configurable between 0 ... 26 mA
Transmitter supply voltage		15 V at 20 mA
Transfer characteristics		
Deviation		
After calibration		0.1 % of the signal range at 20 °C (68 °F)
Influence of ambient temperature		0.1 %/10 K of the signal range
Resolution		12 Bit (0 ... 26 mA)
Refresh time		100 ms
Indicators/settings		
LED indicator		Power LED (P) green: supply Diagnostic LED (I) red: module fault , red flashing: communication error , white: fixed parameter set (parameters from com unit are ignored) , white flashing: requests parameters from com unit Status LED (1-4) red: line fault (lead breakage or short circuit)
Coding		optional mechanical coding via front socket
Directive conformity		
Electromagnetic compatibility		
Directive 2004/108/EC		EN 61326-1:2006
Conformity		
Electromagnetic compatibility		
Degree of protection		IEC 60529:2000
Environmental test		EN 60068-2-14:2009
Shock resistance		EN 60068-2-27:2009
Vibration resistance		EN 60068-2-6:2008
Damaging gas		EN 60068-2-42:2003
Relative humidity		EN 60068-2-78:2001
Ambient conditions		
Ambient temperature		-20 ... 60 °C (-4 ... 140 °F)
Storage temperature		-25 ... 85 °C (-13 ... 185 °F)
Relative humidity		95 % non-condensing
Shock resistance		shock type I, shock duration 11 ms, shock amplitude 50 m/s ² , number of shock directions 6, number of shocks per direction 100
Vibration resistance		frequency range 5 ... 500 Hz, amplitude 5 ... 13.2 Hz ± 1.5 mm, 13.2 ... 100 Hz 1g, sweep rate 1 octave/min, duration 10 sweeps 5 Hz - 100 Hz - 5 Hz
Damaging gas		for plugs: 21 days in 25 ppm SO ₂ , at 25 °C and 75 % rel. humidity, device G3
Mechanical specifications		
Degree of protection		IP20 when mounted on backplane
Connection		removable front connector with screw flange (accessory) wiring connection via spring terminals (0.14 ... 1.5 mm ²) or screw terminals (0.08 ... 1.5 mm ²)
Mass		approx. 150 g
Dimensions		32 x 100 x 103 mm (1.26 x 3.9 x 4 in)
Data for application in connection with Ex-areas		
EC-Type Examination Certificate		BVS 12 ATEX E 024 X for additional certificates see www.pepperl-fuchs.com
Group, category, type of protection		Ⓔ II 3(1) G Ex nA [ia Ga] IIC T4 Gc Ⓔ I (M1) [Ex ia Ma] I Ⓔ II (1) D [Ex ia Da] IIIC

Release date 2015-03-10 13:36 Date of issue 2015-03-10 239076_eng.xml

Refer to "General Notes Relating to Pepperl+Fuchs Product Information".

Supply		
Voltage	U_o	27 V
Current	I_o	90 mA
Power	P_o	588 mW (linear characteristic)
Input		
Voltage	U_o	0.7 V
Current	I_o	2.78 mA
Power	P_o	2 mW (trapezoid characteristic curve)
Internal capacitance	C_i	242 nF
Internal inductance	L_i	0 mH
Electrical isolation		
Input/power supply, internal bus	safe electrical isolation acc. to EN 60079-11, voltage peak value 375 V	
Directive conformity		
Directive 94/9/EC	EN 60079-0:2009 EN 60079-11:2012 EN 60079-15:2010 EN 60079-26:2007 EN 50303:2000	
International approvals		
UL approval	E106378	
IECEx approval	BVS 12.0055X	
Approved for	Ex nA [ia Ga] IIC T4 Gc [Ex ia Da] IIIC [Ex ia Ma] I	
General information		
System information	The module has to be mounted in appropriate backplanes (LB9***) in Zone 2 or outside hazardous areas. Here, the corresponding declaration of conformity has to be observed. For use in hazardous areas (e. g. Zone 2, Zone 22 or Div. 2) the module must be installed in an appropriate enclosure.	
Supplementary information	EC-Type Examination Certificate, Statement of Conformity, Declaration of Conformity, Attestation of Conformity and instructions have to be observed where applicable. For information see www.pepperl-fuchs.com .	

Release date 2015-03-10 13:36 Date of issue 2015-03-10 239076_eng.xml