

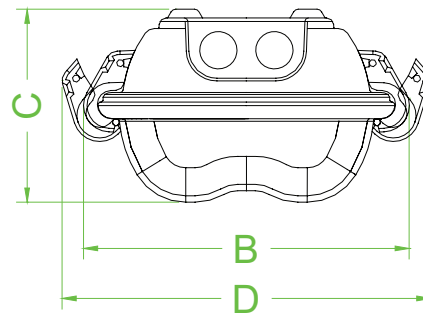

### Dimensions (mm)

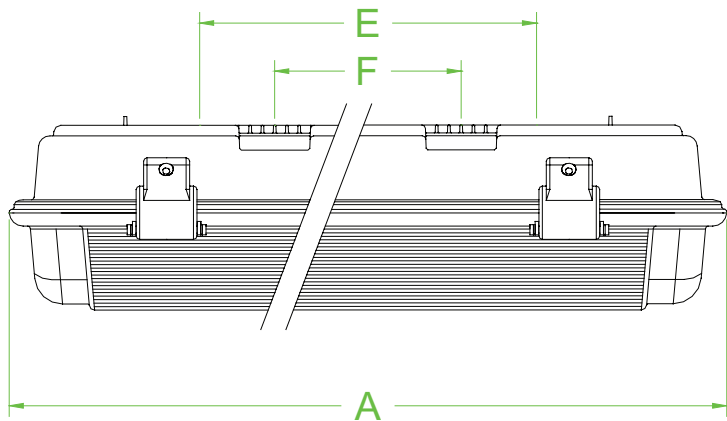

### Features

- Power 2 x 58 W
- Installation in Zone 2 and Zone 22
- Electronic HF control gear
- Suitable for 220-240V AC 50/60Hz operation
- Multiple locking points on diffuser that can be hinged from both sides
- Fast opening and closing of fitting via snap shut fasteners
- Anti-glare diffuser cover
- Stainless steel surface mounting brackets supplied as standard
- Minimum of 3 hour duration in emergency mode

### Technical data

#### Electrical specifications

Operating voltage	220 ... 240 V 50Hz / 60Hz
Operating current	0.51 A
Terminal capacity	2.5 mm <sup>2</sup> Connection block suitable for through wiring
Control gear	high frequency electronic ballast
Fitting type	Ceiling light fitting
Lamps	T26 bi-pin fluorescent tube
Number of lamps	2
Length	1500 mm ( 5 ft )
Power	2 x 58 W
Emergency operation	maintained
Operation time	3 h

#### Conformity

Protection degree	EN 60529
-------------------	----------

#### Ambient conditions

Ambient temperature	0 ... 30 °C (32 ... 86 °F)
---------------------	----------------------------

#### Mechanical specifications

Cover fixing	stainless steel snap shut fasteners
Protection degree	IP66
Cable entry	
Number of cable entries	4 x M20 2 at each end
Material	
Housing	Polycarbonate
Lamp cover	Polycarbonate
Reflector	0.6 mm Mild steel
Finish	Body: as moulded reflector: epoxy powder coated, white
Seal	polyurethane foam

Mass	approx. 5.3 kg
Dimensions	
A	1590 mm
B	173 mm
C	110 mm
D	230 mm
F	1000 mm
Mounting	2 x stainless steel removable mounting brackets
Grounding	Internal connection
<b>Data for application in connection with Ex-areas</b>	
EC-Type Examination Certificate	FTZU 05 ATEX 0200X
Group, category, type of protection, temperature class	⊕ II 3 GD Ex nA tD A II T5 T75°C
<b>International approvals</b>	
GOST-R approval	GOST-R B02432
<b>General information</b>	
Supplementary information	EC-Type Examination Certificate, Statement of Conformity, Declaration of Conformity, Attestation of Conformity and instructions have to be observed where applicable. For information see <a href="http://www.pepperl-fuchs.com">www.pepperl-fuchs.com</a> .
<b>Accessories</b>	
Designation	1 x nylon non-armoured Ex e cable gland 3 x nylon Ex e sealing plugs