



**Model Number**

**DK12-11-5215**

Print mark contrast sensor  
with 5-pin, M12 x 1 connector

**Features**

- Diffuse mode sensor for recording any print mark
- TEACH-IN, static and dynamic
- 50 µs response time, suitable for extremely rapid scanning processes

**Dimensions**

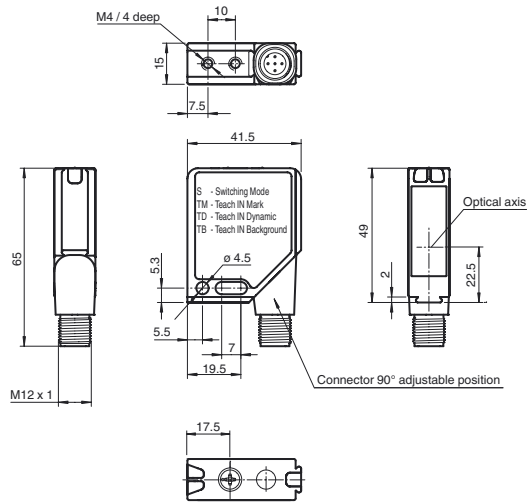

**Electrical connection**

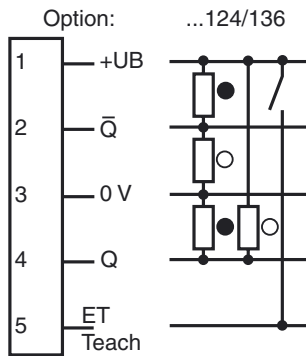

**Pinout**

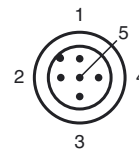

**Indicators/operating means**

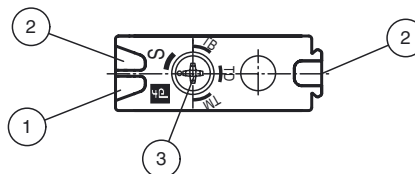

1	Operating display green
2	Switch state yellow
3	Teach-In switch

Release date: 2013-09-24 10:07 Date of issue: 2013-10-15 239510\_eng.xml

Refer to "General Notes Relating to Pepperl+Fuchs Product Information".

Pepperl+Fuchs Group  
www.pepperl-fuchs.com

USA: +1 330 486 0001  
fa-info@us.pepperl-fuchs.com

Germany: +49 621 776 4411  
fa-info@de.pepperl-fuchs.com

Singapore: +65 6779 9091  
fa-info@sg.pepperl-fuchs.com

**Technical data****General specifications**

Sensor range	11 mm ± 2 mm
Light source	LED
Light type	modulated visible red light , 660 nm
Light spot representation	0.7 mm (effective light spot diameter)
Angle deviation	max. ± 3°
Teach-In	static and dynamic Teach-In

**Functional safety related parameters**

MTTF <sub>d</sub>	750 a
Mission Time (T <sub>M</sub> )	20 a
Diagnostic Coverage (DC)	60 %

**Indicators/operating means**

Operation indicator	LED green, statically lit Power on , short-circuit : LED green flashing (approx. 4 Hz)
Function indicator	2 LEDs yellow, light up in case of detection
Teach-In indicator	Teach-In mark: LED green/yellow equiphase flashing; 2,5 Hz . Teach-In background: LED green/yellow non equiphase flashing; 2,5 Hz . Teach-In dynamic: LED green/yellow equiphase flashing; 1.0 Hz . Teach Error:LED green/yellow non equiphase flashing; 8.0 Hz .
Control elements	Teach-In rotary switch for Switching operation, Teach-In mark, Teach-In background and dynamic Teach-In

**Electrical specifications**

Operating voltage	U <sub>B</sub>	10 ... 30 V DC
Ripple		10 %
No-load supply current	I <sub>0</sub>	≤ 80 mA

**Input**

Function input	Ext. Teach-In input (ET)
----------------	--------------------------

**Output**

Switching type	light/dark on	
Signal output	2 push-pull (4 in 1) outputs, complementary, short-circuit proof, reverse polarity protected	
Switching voltage	max. 30 V DC	
Switching current	max. 100 mA	
Switching frequency	f	10 kHz
Response time		50 μs

**Ambient conditions**

Ambient temperature	-20 ... 60 °C (-4 ... 140 °F)
Storage temperature	-40 ... 75 °C (-40 ... 167 °F)

**Mechanical specifications**

Protection degree	IP67
Connection	Metal connector, M12, 5-pin, 90° rotatable
Material	
Housing	Frame: nickel plated, die cast zinc, Laterals: glass-fiber reinforced plastic PC
Optical face	Plastic pane
Mass	60 g

**Compliance with standards and directives**

Standard conformity	
Product standard	EN 60947-5-2:2007 IEC 60947-5-2:2007

**Approvals and certificates**

Protection class	II, rated voltage ≤ 250 V AC with pollution degree 1-2 according to IEC 60664-1
UL approval	cULus Listed , Class 2 power source
CCC approval	CCC approval / marking not required for products rated ≤36 V

**Curves/Diagrams**

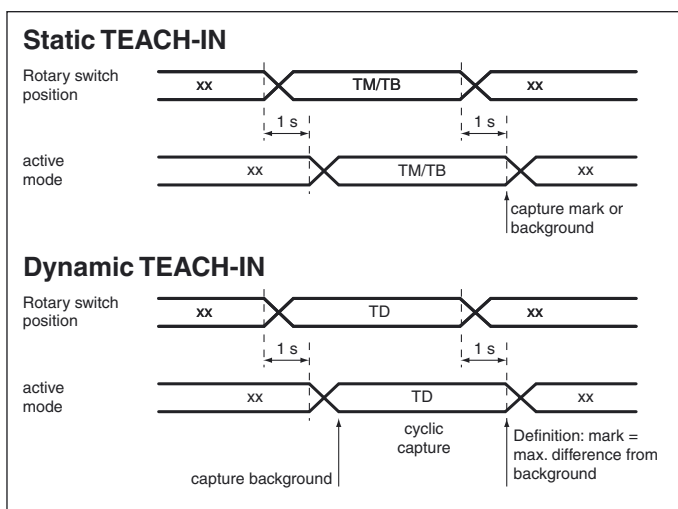
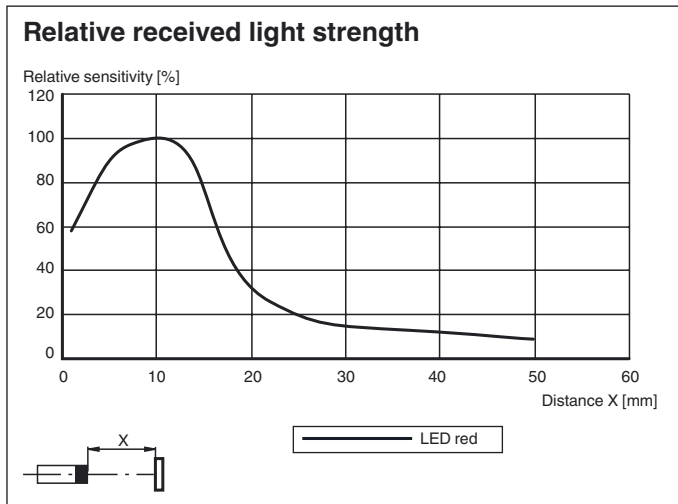

**Recommended setting**

1. Turn the Teach-In switch to position "S".
2. Position the light beam on the white part of the mark (W).



3. Turn the Teach-In switch to position "TM" and wait until the green and yellow LEDs start flashing simultaneously.
4. Turn the Teach-In switch to position "TB" and wait about 1 second.
5. Now position the light beam on the black part of the mark (B).
6. Turn the Teach-In switch to position "S" and wait about 1 second.

-> The mark is now taught in

More information about settings can be found in the "Setting information" section

**Adjustment**

In the case of reflecting or shiny object surfaces, the sensor must be tilted by approx. 10° against the material surface.

**Teach-In via rotary switch**

**Teach-In via rotary switch in four settings: Switch mode, Teach-In Mark, Teach-In Background and Dynamical Teach-In.**

A change of the switch setting needs to pass a 1 second time lock. That means that the switch must be for at least 1 second in the new position before the sensor accepts the required mode (indicated by the flashing sequence of the indication LEDs).

**Statical Teach-In**

Release date: 2013-09-24 10:07 Date of issue: 2013-10-15 239510\_eng.xml

Static Teach-In mode (TM/TB) allows the teach of mark and background at the same time (one after the other but independently of the order) or separately. There is no need to teach always both mark and background.

#### **Setting TM (Teach-In Mark)**

Teach-In starts with a continuous value capturing. The object's colour may change. When the switch position changes, the last captured value will be saved as the marks value. During the "Teach-In Mark" mode, the green and the yellow LEDs are flashing simultaneously ( $f = 2.5 \text{ Hz}$ ).

#### **Setting TB (Teach-In Background)**

Same function as described above (TM setting).

During the "Teach-In Background" mode the green and the yellow LEDs are flashing alternating ( $f = 2.5 \text{ Hz}$ ).

#### **Dynamical Teach-In**

##### **Setting TD (Teach-In Dynamic)**

The Teach-In procedure starts and a continuous value capturing is carried out. The first captured signals after entering the "Dynamical Teach-In" mode are interpreted by the sensor as the background. The maximum signal variation during the entire "Teach-In Dynamic" mode will be interpreted as the print mark.

During the "Teach-In Dynamic" mode the green and the yellow LEDs are flashing simultaneously ( $f = 1.0 \text{ Hz}$ ).

#### **Switch mode (normal operation)**

##### **Setting S (Switching Mode)**

This switch setting terminates the actual Teach-In mode. Signal evaluation for both mark and background is now performed.

- a.) Teach-In successfully finished --> switch mode:  
The switching level is set to the centre between mark and background signal.  
The switching outputs Q1/PNP and Q2/NPN are activated when the taught mark is detected.
- b.) Alarm function:  
In case of too weak contrast, the emitter will be deactivated. The yellow and the green LEDs are flashing alternating with a frequency of approx. 8.0 Hz. The sensor returns to the switch mode (normal operation) after 7 seconds without changing the saved values.

## **External Teach-In input**

The desired operating mode is set in switch position S by connecting a high pulse of a certain width:

Teach-In Dynamic (TD)	420 ms ... 450 ms
Teach-In Background (TB)	320 ms ... 350 ms
Teach-In Mark (TM)	220 ms ... 250 ms
Switching Mode (S)	120 ms ... 150 ms

The description of the individual operating modes corresponds to the Teach-In via rotary switch.

During the external Teach-In the function of the rotary switch is deactivated.

An external Teach-In procedure must be completed with a signal for requesting the Switching Mode (S).