



Model Number

ML4.2-54-G/40b/110/115

Retroreflective sensor
with 2 m fixed cable

Features

- High-precision sensors for complex applications
- Miniature design with very robust and versatile mounting options
- Optical surface made of scratch-resistant glass for areas that are prone to high levels of dirt
- Reliable recognition of reflective objects and clear glass
- Two machines in one: clear object detection or reflection operating mode with long range
- TEACH-IN switch for setting the contrast detection levels
- Automatic adjustment in case of soiling in contrast detection mode

Product information

The ML4.2 series is characterized by a robust, powerful and standard design in a miniature housing. The housing offers IP67/IP69K degree of protection, a scratch- and chemical-resistant lens, highly visible LEDs and robust all-metal bushings for mounting. Adjustable and tamper-proof sensors are available with a universal push-pull output and an electrical light ON/dark ON switch. The sensors have a high ambient light limit. Reflections from the background are suppressed. The unusually small, sharp light spot and the quick response time offer maximum switching precision on object edges.. Both red and infrared light sources are available. A high-performance fixed focus background suppressor is a useful feature. The sensors are suitable for precise object detection and open up a wide range of application fields.

Dimensions

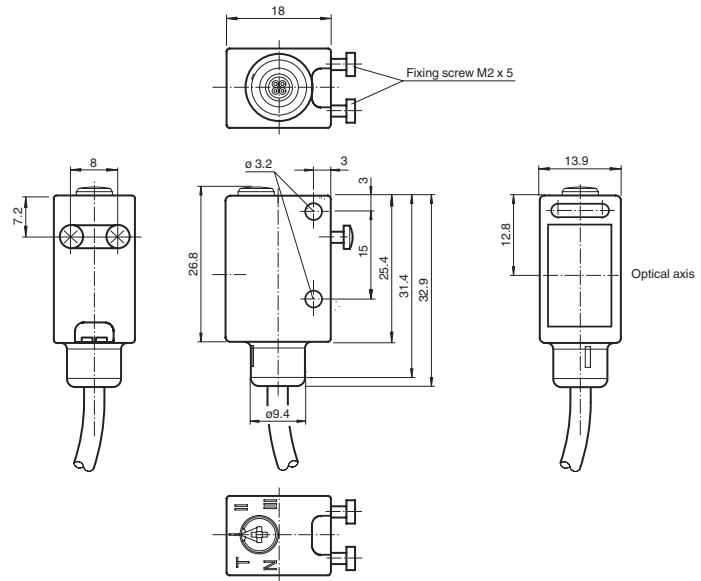

Electrical connection

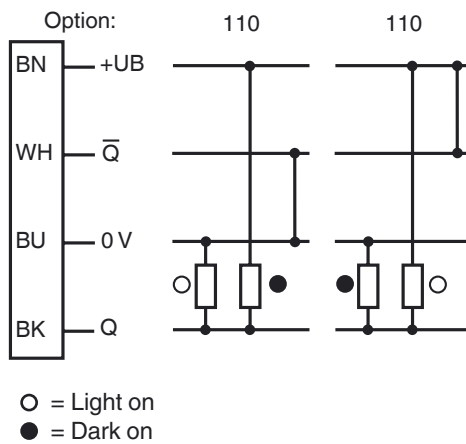

Indicators/operating means

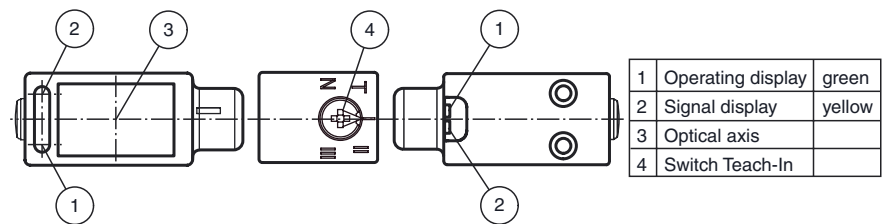

Release date: 2013-04-18 12:22 Date of issue: 2013-05-13 239664_eng.xml

Technical data**General specifications**

Effective detection range	0 ... 3.5 m in TEACH mode 0 ... 5 m at switch position "N"
Reflector distance	0 ... 3.5 m in TEACH mode 0 ... 5 m at switch position "N"
Threshold detection range	6 m
Reference target	H85-2 reflector
Light source	LED
Light type	modulated visible red light , 660 nm
Angle deviation	max. $\pm 1^\circ$
Diameter of the light spot	approx. 40 mm at detection range 1 m
Angle of divergence	1.7 °
Ambient light limit	
Continuous light	40000 Lux
Modulated light	5000 Lux

Functional safety related parameters

MTTF _d	980 a
Mission Time (T _M)	20 a
Diagnostic Coverage (DC)	0 %

Indicators/operating means

Operating display	LED green, statically lit Power on , Undervoltage indicator: Green LED, pulsing (approx. 0.8 Hz) , short-circuit : LED green flashing (approx. 4 Hz)
Function display	LED yellow: switching state ; Stability control ; Teach-In
Controls	5-step switch for setting the contrast detection levels.

Contrast detection levels	switch position I: 10 % - clean, water filled PET bottles switch position II: 18 % - clear glass bottles switch position III: 40 % - coloured glass or opaque materials adjustable due to TEACH-IN switch
---------------------------	---

Electrical specifications

Operating voltage	U _B	10 ... 30 V DC
Ripple		max. 10 %
No-load supply current	I ₀	< 15 mA at 24 V DC

Output

Switching type	light/dark on electrically switchable , Pin 2 open or at 0V = light switching, Pin 2 at +UB = dark switching	
Signal output	1 push-pull (4 in 1) output, short-circuit protected, reverse polarity protected	
Switching voltage	max. 30 V DC	
Switching current	max. 100 mA	
Voltage drop	U _d	≤ 2.5 V DC
Switching frequency	f	1 kHz
Response time		500 μs

Ambient conditions

Ambient temperature	-20 ... 60 °C (-4 ... 140 °F)
Storage temperature	-20 ... 75 °C (-4 ... 167 °F)

Mechanical specifications

Protection degree	IP67 / IP69K
Connection	2 m fixed cable
Material	
Housing	ABS
Optical face	glass pane
Cable	PUR
Mass	approx. 50 g

Compliance with standards and directives

Standard conformity	
Product standard	EN 60947-5-2:2007 IEC 60947-5-2:2007
Shock and impact resistance	IEC / EN 60068. half-sine, 40 g in each X, Y and Z directions
Vibration resistance	IEC / EN 60068-2-6. Sinus. 10 -2000 Hz, 10 g in each X, Y and Z directions

Approvals and certificates

CE conformity	yes
UL approval	cULus Listed
CCC approval	CCC approval / marking not required for products rated ≤36 V

Accessories**OMH-4.1**

Mounting Clamp

OMH-ML6

Mounting bracket

OMH-ML6-Z

Mounting bracket

OMH-ML6-U

Mounting bracket

OMH-11-02 Aperture-V-H 0.5 mm

Slit diaphragm can be affixed for detecting very small parts

OMH-11-04 Aperture-V-H 1.0 mm

Slit diaphragm can be affixed for detecting very small parts

OMH-11-06 Aperture-V-H 1.5 mm

Slit diaphragm can be affixed for detecting very small parts

OMH-11-08 Aperture-V-H 2.0 mm

Slit diaphragm can be affixed for detecting very small parts

REF-H85-2

Reflector, rectangular 84.5 mm x 84.5 mm, mounting holes

REF-C110-2Reflector, round \varnothing 84 mm, central mounting hole**REF-H60-2**

Reflector with mounting holes

REF-VR10

Reflector, rectangular 60 mm x 19 mm, mounting holes

OFR-100/100

Reflective tape 100 mm x 100 mm

REF-A17Reflector, round \varnothing 20.5 mm, self-adhesive**REF-A25**Reflector, round \varnothing 25 mm, self-adhesive**REF-MH23**

Reflector with Micro-structure, rectangular 23 mm x 13.8 mm, diagonal mounting hole

REF-CLIP50HTReflector, round \varnothing 50 mm, snap-in, high temperature applications**REF-H50HT**

Reflector, rectangular 50.9 mm x 50.9 mm, mounting holes, fixing strap

Other suitable accessories can be found at www.pepperl-fuchs.com

Curves/Diagrams

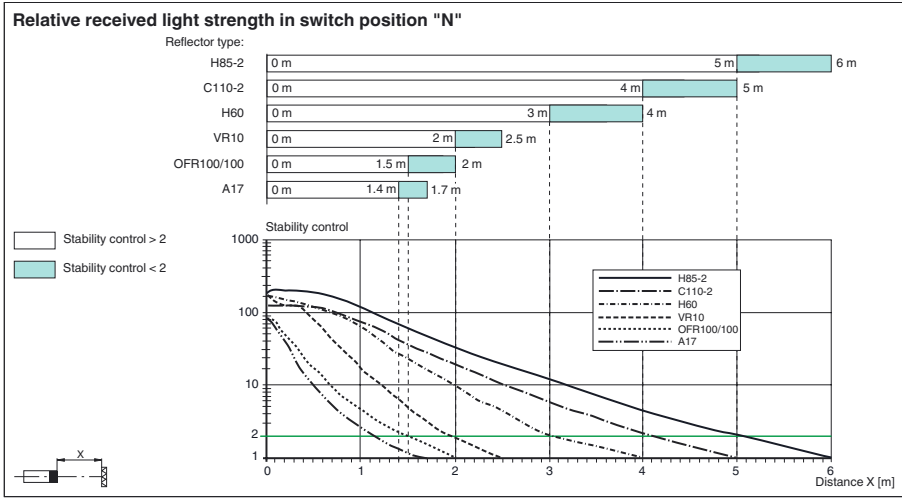
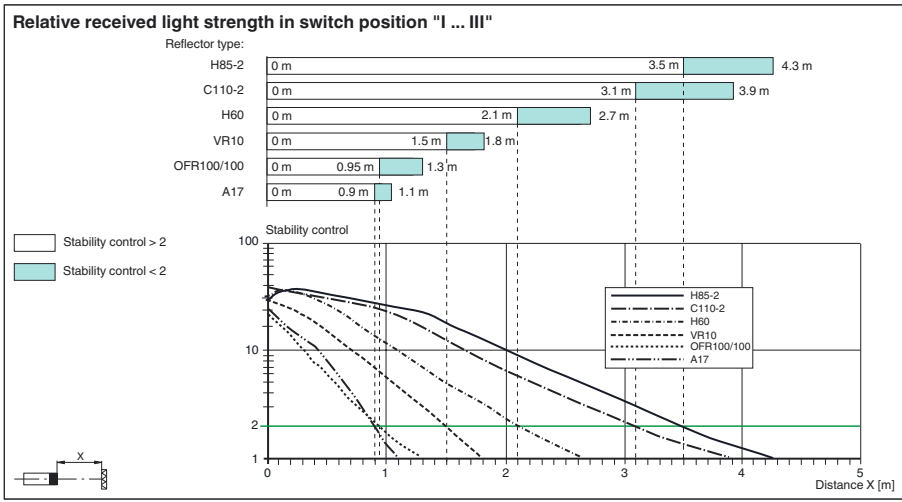
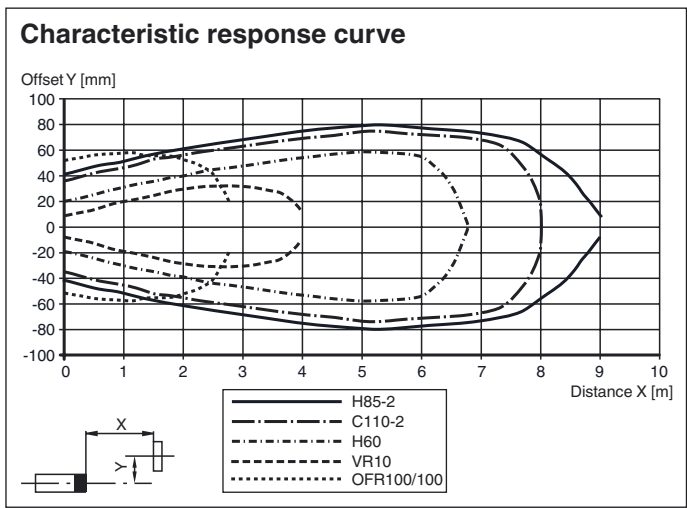

Release date: 2013-04-18 12:22 Date of issue: 2013-05-13 239664_eng.xml

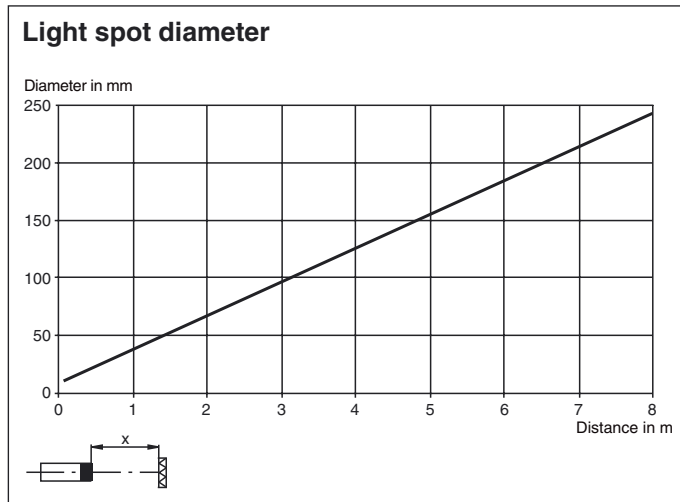

Additional information

Adjustment instructions for Teach-In operation:

Step	Switch position	LED green	LED yellow	Time/frequency	Explanations/comments
1	N	on	flashes	4/s	In switch position "N" directed towards reflector. Reflector detected without function reserve .
	N	on	on	-	In switch position "N" directed towards reflector. Reflector detected with function reserve (recommended).
2	T	off/on	on	200 ms	The selection of a new switch position is indicated by the green LED going out for a short time. This also applies to the selection of the other switch positions.
	T	flashes	flashes	2.5 s	<i>Slow</i> alternating flashing: Teach-In process has been performed correctly . Max. duration of the Teach-In process: 2 s
	T	flashes	flashes	8/s	<i>Quick</i> alternating flashing: Teach-In process has not been performed correctly . (e.g. receiver signal not sufficient, sensor not directed correctly towards reflector). Status is terminated by turning switch to position N.
3/1	I	on	on	-	Contrast detection 10 % is activated. (e.g. clean PET bottles filled with water)
3/2	II	on	on	-	Contrast detection 18 % is activated. (e.g. clear glass bottles)
3/3	III	on	on	-	Contrast detection 40 % is activated. (e.g. coloured glass or non-transparent materials)