

Features

- 2-channel signal conditioner
- 24 V DC supply (Power Rail)
- Dry contact or NAMUR inputs
- 2 passive transistor outputs
- Reversible mode of operation
- Line fault detection (LFD)
- Housing width 12.5 mm
- Connection via spring terminals
- Up to SIL2 acc. to IEC 61508

Function

This signal conditioner provides the galvanic isolation between field circuits and control circuits.

The device transfers digital signals (NAMUR sensors or dry contacts) from the field to the control system.

Each input controls a passive transistor output.

Via switches the mode of operation can be reversed and the line fault detection can be switched off.

A fault is signaled by LEDs acc. to NAMUR NE44 and a separate collective error message output.

Assembly

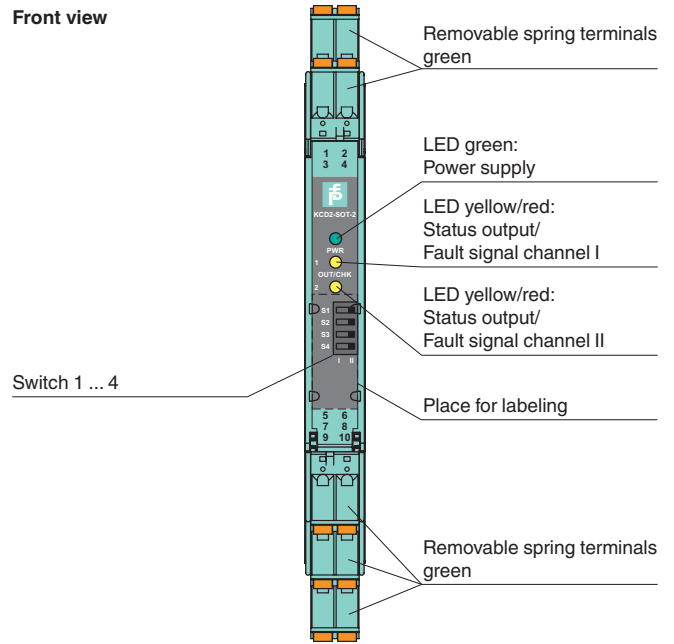

CE

SIL2

Connection

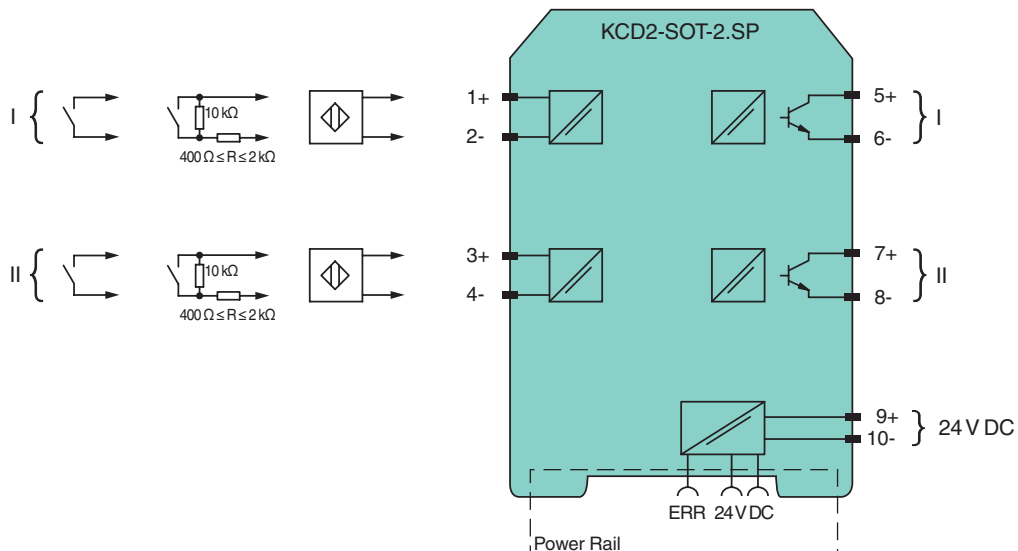

Release date 2013-08-07 17:26 Date of issue 2015-02-16 240648_eng.xml

Refer to "General Notes Relating to Pepperl+Fuchs Product Information".

Pepperl+Fuchs Group
www.pepperl-fuchs.com

USA: +1 330 486 0002
pa-info@us.pepperl-fuchs.com

Germany: +49 621 776 2222
pa-info@de.pepperl-fuchs.com

Singapore: +65 6779 9091
pa-info@sg.pepperl-fuchs.com

General specifications		
Signal type		Digital Input
Supply		
Connection		Power Rail or terminals 9+, 10-
Rated voltage	U_n	19 ... 30 V DC
Ripple		≤ 10 %
Rated current	I_n	30 ... 20 mA
Power loss		≤ 800 mW including maximum power dissipation in the output
Input		
Connection		terminals 1+, 2-; 3+, 4-
Rated values		acc. to EN 60947-5-6 (NAMUR)
Open circuit voltage/short-circuit current		approx. 10 V DC / approx. 8 mA
Switching point/switching hysteresis		1.2 ... 2.1 mA / approx. 0.2 mA
Line fault detection		breakage I ≤ 0.1 mA , short-circuit I ≥ 6.5 mA
Pulse/Pause ratio		≥ 100 μs / ≥ 100 μs
Output		
Connection		terminals 5, 6; 7, 8
Rated voltage	U_n	30 V DC
Rated current	I_n	50 mA
Response time		≤ 200 μs
Signal level		1-signal: (external voltage) - 3 V max. for 50 mA 0-signal: blocked output (off-state current ≤ 10 μA)
Output I		signal ; Transistor
Output II		signal ; Transistor
Collective error message		Power Rail
Transfer characteristics		
Switching frequency		≤ 5 kHz
Electrical isolation		
Input/Output		reinforced insulation acc. to EN 50178, rated insulation voltage 300 V _{eff}
Input/power supply		reinforced insulation acc. to EN 50178, rated insulation voltage 300 V _{eff}
Output/power supply		basic insulation according to EN 50178, rated insulation voltage 50 V _{eff}
Output/Output		basic insulation according to EN 50178, rated insulation voltage 50 V _{eff}
Directive conformity		
Electromagnetic compatibility		
Directive 2004/108/EC		EN 61326-1:2006
Conformity		
Electromagnetic compatibility		NE 21:2011
Degree of protection		IEC 60529:2001
Protection against electrical shock		IEC 61010-1:2010
Input		EN 60947-5-6:2000
Ambient conditions		
Ambient temperature		-20 ... 60 °C (-4 ... 140 °F)
Mechanical specifications		
Degree of protection		IP20
Mass		approx. 100 g
Dimensions		12.5 x 114 x 119 mm (0.5 x 4.5 x 4.7 in) , housing type A2
Mounting		on 35 mm DIN mounting rail acc. to EN 60715:2001
General information		
Supplementary information		Statement of Conformity, Declaration of Conformity, Attestation of Conformity and instructions have to be observed where applicable. For information see www.pepperl-fuchs.com .

Release date 2013-08-07 17:26 Date of issue 2015-02-16 240648_eng.xml

Configuration

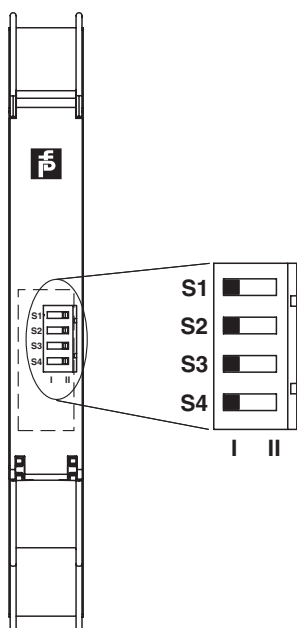

Switch settings

S	Function		Position
1	Mode of operation output I (active)	with high input current	I
		with low input current	II
2	Mode of operation output II (active)	with high input current	I
		with low input current	II
3	Line fault detection of the input I	ON	I
		OFF	II
4	Line fault detection of the input II	ON	I
		OFF	II

Operating status

Control circuit	Input signal
Initiator high impedance/contact opened	low input current
Initiator low impedance/contact closed	high input current
Lead breakage, lead short-circuit	Line fault

Factory settings: switch 1, 2, 3 and 4 in position I

Accessories

Power feed module KFD2-EB2

The power feed module is used to supply the devices with 24 V DC via the Power Rail. The fuse-protected power feed module can supply up to 150 individual devices depending on the power consumption of the devices. Collective error messages received from the Power Rail activate a galvanically-isolated mechanical contact.

Power Rail UPR-03

The Power Rail UPR-03 is a complete unit consisting of the electrical insert and an aluminium profile rail 35 mm x 15 mm. To make electrical contact, the devices are simply engaged.

Profile Rail K-DUCT with Power Rail

The profile rail K-DUCT is an aluminum profile rail with Power Rail insert and two integral cable ducts for system and field cables. Due to this assembly no additional cable guides are necessary.



Power Rail and Profile Rail must not be fed via the device terminals of the individual devices!