

Model Number

DK12-11-IO/A/92/136

Print mark contrast sensor with 4-pin, M12 x 1 connector

Features

- IO-link interface for service and process data
- Diffuse mode sensor for recording any print mark
- TEACH-IN, static and dynamic
- 40 µs response time, suitable for extremely rapid scanning processes
- 3 emitter colors: green, red and blue

Product information

The contrast sensor DK12 with an IO-Link interface makes continuous communication with the diagnosis system and the parameter assignment up to the sensor level available for the first time. That way it is ensured that the intelligence which is already integrated in each DK12-contrast sensor, is harnessed to the full. This will offer a number of special advantages during service (remedial action, maintenance and device exchange), commissioning (cloning, identification, configuration and localization) or during operation (change of job, continuous parameter monitoring und online diagnosis).

Release date: 2015-02-26 13:44 Date of issue: 2015-02-26 244277_eng.xml

Dimensions

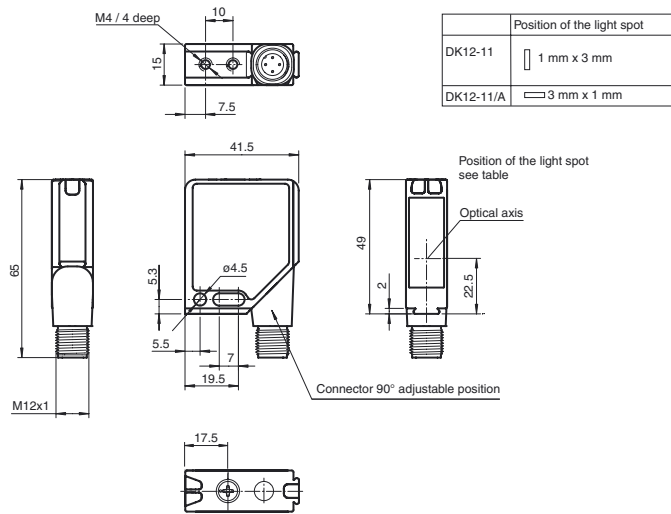

Electrical connection

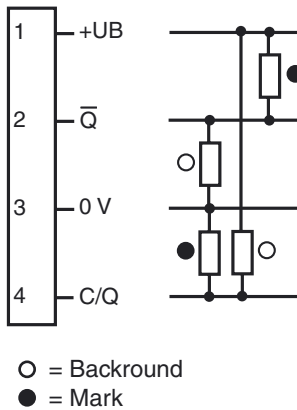

Pinout

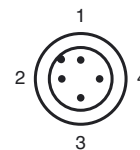

Indicators/operating means

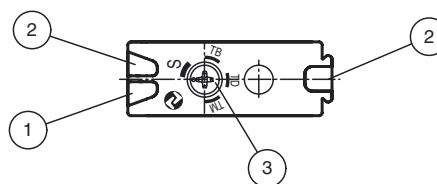

| | |
|---|-------------------------|
| 1 | Operating display green |
| 2 | Switch state yellow |
| 3 | Teach-In switch |

Technical data**General specifications**

| | |
|---------------------------|---|
| Sensor range | 11 mm ± 2 mm |
| Light source | 3 LEDs (R,G,B) |
| Light type | Visible green/red/blue, modulated light |
| Light spot representation | 3 mm x 1 mm , light spot perpendicular to housing |
| Angle deviation | max. ± 3° |
| Teach-In | static and dynamic Teach-In |

Indicators/operating means

| | |
|---------------------|---|
| Operation indicator | LED green, statically lit Power on , Undervoltage indicator: Green LED, pulsing (approx. 0.8 Hz) , short-circuit : LED green flashing (approx. 4 Hz) , IO link communication: green LED goes out briefly (1 Hz) |
| Function indicator | 2 LEDs yellow, light up in case of detection |
| Teach-In indicator | Teach-In mark: LED green/yellow equiphase flashing; 2,5 Hz . Teach-In background: LED green/yellow non equiphase flashing; 2,5 Hz . Teach-In dynamic: LED green/yellow equiphase flashing; 1.0 Hz . Teach Error:LED green/yellow non equiphase flashing; 8.0 Hz . |
| Control elements | Teach-In rotary switch for Switching operation, Teach-In mark, Teach-In background and dynamic Teach-In |

Electrical specifications

| | | |
|------------------------|-------|--|
| Operating voltage | U_B | 10 ... 30 V DC / when operating in IO-Link mode: 18 ... 30 V |
| Ripple | | 10 % |
| No-load supply current | I_0 | ≤ 60 mA at 24 V supply voltage |

Interface

| | |
|----------------|--------------------|
| Interface type | IO-Link |
| Protocol | IO-Link V1.0 |
| Mode | COM 2 (38.4 kBaud) |

Output

| | |
|---------------------|--|
| Switching type | light/dark on |
| Signal output | 2 push-pull (4 in 1) outputs, complementary, short-circuit proof, reverse polarity protected |
| Switching voltage | max. 30 V DC |
| Switching current | max. 100 mA |
| Switching frequency | f 12.5 kHz |
| Response time | 40 μs |

Ambient conditions

| | |
|---------------------|--------------------------------|
| Ambient temperature | -20 ... 60 °C (-4 ... 140 °F) |
| Storage temperature | -40 ... 75 °C (-40 ... 167 °F) |

Mechanical specifications

| | |
|----------------------|---|
| Degree of protection | IP67 |
| Connection | 4-pin, M12 metal connector , can be rotated 90° |
| Material | |
| Housing | Frame: nickel plated, die cast zinc, Laterals: glass-fiber reinforced plastic PC |
| Optical face | Plastic pane |
| Mass | 60 g |

Compliance with standards and directives

| | |
|---------------------|---|
| Standard conformity | |
| Product standard | EN 60947-5-2:2007 IEC 60947-5-2:2007 |

Approvals and certificates

| | |
|------------------|---|
| Protection class | II, rated voltage ≤ 250 V AC with pollution degree 1-2 according to IEC 60664-1 |
| UL approval | cULus Listed , Class 2 power source |
| CCC approval | CCC approval / marking not required for products rated ≤36 V |

Accessories**DK12-11 IODD**

IODD for communication with DK12-11-IO-Link sensors

IO-Link-Master-USB DTM

Communication DTM for use of IO-Link-Master

PACTware 4.X

FDT Framework

IODD Interpreter DTM

Software for the integration of IODDs in a frame application (e. g. PACTware)

IO-Link-Master02-USB

IO-Link master, supply via USB port or separate power supply, LED indicators, M12 plug for sensor connection

DK12-11-IO-Link DTM

Device DTM for communication with DK12-11-IO-Link sensors

Additional accessories can be found in the Internet.

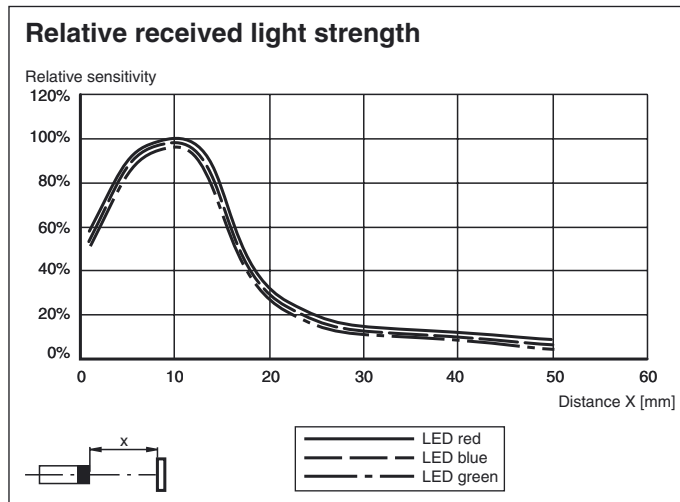

IO-Link Description

IO-Link is a standard for uniform linking of communications-capable sensors and switching devices to the control level by means of an economical point-to-point connection.

IO-Link provides a bidirectional point-to-point link between I/O modules and field device that combines serial communication in half-duplex mode for transferring process data, parameterization, diagnostic evaluation, and power supply. Communication is based on a master-slave structure in which the master controls the interface access to the slave (device) cyclically.

IO link function

The IO link operating mode is indicated by the green LED indicator with a short interruption ($f = 1$ Hz). IO link communication simultaneously provides process data (measurement data from the sensor) and access to requirement data.

The requirement data contains the following information:

Identification:

- Manufacturer information
- Product ID
- User-specific ID

Device parameters:

- Teach-in parameters
- Operating parameters
- Configuration parameters
- Device commands

Diagnostic messages and warnings

Setting information

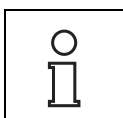

If the object surface is reflective or shiny, the sensor should be angled at approx. 10° to the surface of the material.

Teach-In using the rotary switch

Teach-In using the rotary switch in four positions - switching operation, Teach-In Mark, Teach-In Background and dynamic Teach-In.

To change the switch position, a time lock of approximately 2 seconds must be adhered to in each case. This means that the rotary switch must remain in a new position constantly for 2 seconds in order that the mode requested is accepted by the sensor (indicated by a change in the flashing function of the display LEDs).

Static Teach-In

The mark or the background can be taught-in in static Teach-In mode (TM/TB), either together (in any order) or separately. Therefore it is not mandatory to always teach-in the mark and the background.

TM position (Teach-In Mark)

For teaching-in the mark, when the rotary switch remains in the TM position constantly for 2 seconds. The green and the yellow display LEDs flash simultaneously after teach-in has been completed ($f = 2.5$ Hz).

TB position (Teach-In Background)

For teaching-in the background, when the rotary switch remains in the TB position constantly for 2 seconds. The green and the yellow display LEDs flash alternately after teach-in has been completed ($f = 2.5$ Hz).

Dynamic Teach-In

TD position (Teach-In Dynamic)

The dynamic Teach-In operation begins when the rotary switch remains in the TD position constantly for 2 seconds. Values are then transferred continually. The first signals received after changing to "Dynamic Teach-In" mode are interpreted by the sensor as background. The largest deviation from the background during the entire "Teach-In Dynamic" mode is interpreted as a mark.

During "Teach-In Dynamic" mode, the green and yellow display LEDs flash simultaneously at $f = 1$ Hz.

The dynamic Teach-In operation finishes when the rotary switch remains in a new position constantly for 2 seconds.

Switching mode**S position (Switching Mode)**

Ending the current Teach-In mode, evaluation of the received signals of all 3 transmitter light colors for mark and background.

a.) Teach-In successful --> switching mode

Selection of the most favorable transmitter light color for the taught-in contrast.

The switching threshold is set midway between the mark and the background.

The Q1/PNP and Q2/NPN outputs become active when the taught-in mark is detected.

b.) Alarm function

The taught-in contrast is too low for all 3 transmitter light colors. Automatically changes to switching mode with the last valid values for mark and background.

The yellow and green display LEDs flash alternately at $f = 8$ Hz for approx. 7 seconds.

For parameterization and diagnosis, the sensor can be addressed via the integrated IO link interface. This interface transmits process data in a cyclic manner, and diagnosis data acyclically. For this, connect the sensor to an IO link master and connect the relevant master port to the IO link device. When communication is established successfully, the green operation display LED flashes briefly every 1 s. The sensor can then be configured or diagnosed by the overlying application and send its process data.

The sensor parameters are device-specific and are described in the standardized IO Device Description file (IODD). The IODD can be read into different engineering tools using IODD support from different system providers. The sensor can then be configured or diagnosed using the relevant tool and a user interface generated from the IODD.

The IODD device description, FDT framework application and IODD interpreter are available in the corresponding product description under Software on our homepage, www.pepperl-fuchs.com.