

Features

- 1-channel signal conditioner
- 24 V DC supply (Power Rail)
- Thermocouple, RTD, potentiometer or voltage input
- Voltage output 0/1 V ... 5 V
- Configurable by **PACTware**
- Line fault (LFD) and sensor burnout detection
- Up to SIL2 acc. to IEC 61508/IEC 61511

Function

This signal conditioner is designed to connect RTDs, thermocouples, or potentiometers, and provide a proportional 0/1 V ... 5 V signal.

The barrier offers 3-port isolation between input, output, and power supply.

A removable terminal block K-CJC-** is available for thermocouples when internal cold junction compensation is desired.

A fault is indicated by a red flashing LED per NAMUR NE44 and user-configured fault outputs.

The unit is easily programmed with the **PACTware™** configuration software.

A unique collective error messaging feature is available when used with the Power Rail system.

For additional information, refer to the manual and www.pepperl-fuchs.com.

Assembly

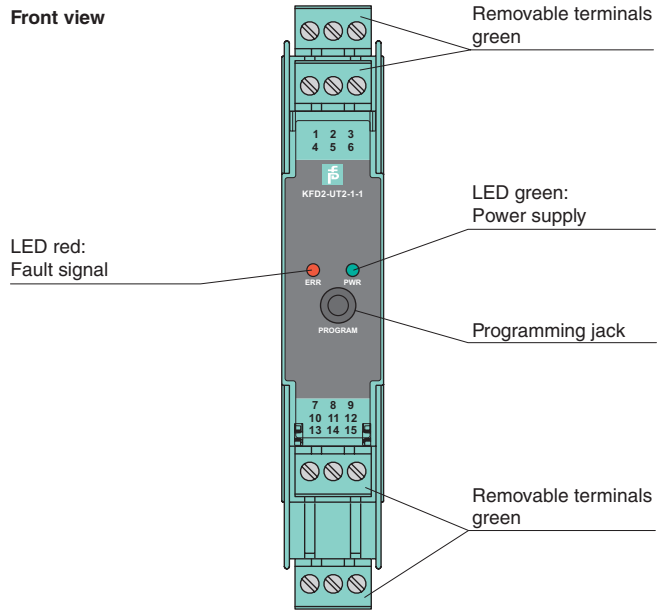

CE

SIL2

Connection

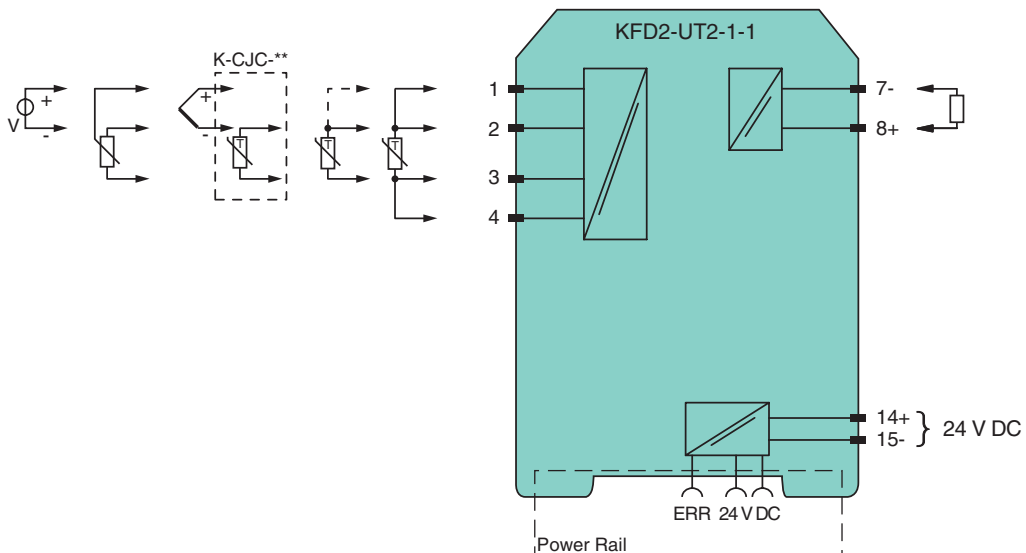

Release date 2014-04-30 14:09 Date of issue 2015-02-16 248760_eng.xml

Refer to "General Notes Relating to Pepperl+Fuchs Product Information".

General specifications	
Signal type	Analog input
Supply	
Connection	terminals 14+, 15- or power feed module/Power Rail
Rated voltage U_n	20 ... 30 V DC
Ripple	within the supply tolerance
Power loss/power consumption	$\leq 0.64 \text{ W} / 0.64 \text{ W}$
Input	
Connection	terminals 1, 2, 3, 4
RTD	type Pt10, Pt50, Pt100, Pt500, Pt1000 (EN 60751: 1995) type Pt10GOST, Pt50GOST, Pt100GOST, Pt500GOST, Pt1000GOST (6651-94) type Cu10, Cu50, Cu100 (P50353-92) type Ni100 (DIN 43760)
Measuring current	approx. 200 μA with RTD
Types of measuring	2-, 3-, 4-wire connection
Lead resistance	$\leq 50 \Omega$ per lead
Measuring circuit monitoring	sensor breakage, sensor short-circuit
Thermocouples	type B, E, J, K, N, R, S, T (IEC 584-1: 1995) type L (DIN 43710: 1985) type TXK, TXKH, TXA (P8.585-2001)
Cold junction compensation	external and internal
Measuring circuit monitoring	sensor breakage
Voltage	selectable within the range -100 ... 100 mV
Potentiometer	0 ... 20 k Ω (2-wire connection), 0.8 ... 20 k Ω (3-wire connection)
Input resistance	$\geq 1 \text{ M}\Omega$ (-100 ... 100 mV)
Output	
Voltage output	0 ... 5 V or 1 ... 5 V ; output resistance: $\leq 5 \Omega$; load: $\geq 10 \text{ k}\Omega$
Connection	terminals 7-, 8+
Fault signal	downscale 0 V or 0.5 V, upscale 5.375 V
Transfer characteristics	
Deviation	
After calibration	Pt100: $\pm (0.06 \%$ of measurement value in K + 0.1 K (4-wire connection)) thermocouple: $\pm (0.05 \%$ of measurement value in $^{\circ}\text{C}$ + 1 K (1.2 K for types R and S)) this includes $\pm 0.8 \text{ K}$ error of the cold junction compensation mV: $\pm 50 \mu\text{V}$ potentiometer: $\pm 0.05 \%$ of full scale, (excludes errors due to lead resistance) output: 1 to 5 V output: $\pm 4 \text{ mV}$ from 0 to 103.1 % of span; 0 to 5 V output: $\pm 4 \text{ mV}$ from 0.3 to 102.5 % of span
Influence of ambient temperature	deviation of CJC included: Pt100: $\pm (0.0015 \%$ of measurement value in K + 0.006 % of span)/K $\Delta T_{\text{amb}}^{\text{)}})$ thermocouple: $\pm (0.02 \text{ K} + 0.005 \%$ of measurement value in $^{\circ}\text{C}$ + 0.006 % of span)/K $\Delta T_{\text{amb}}^{\text{)}})$ mV: $\pm (0.01 \%$ of measurement value + 0.006 % of span)/K $\Delta T_{\text{amb}}^{\text{)}})$ potentiometer: $\pm 0.006 \%$ of span/K $\Delta T_{\text{amb}}^{\text{)}})$ $\text{)} \Delta T_{\text{amb}} = \text{ambient temperature change referenced to } 23 \text{ }^{\circ}\text{C} (296 \text{ K})$
Influence of supply voltage	$< 0.01 \%$ of span
Reaction time	worst case value (sensor breakage and/or sensor short circuit detection enabled) mV: 1 s, thermocouples with CJC: 1.1 s, thermocouples with fixed reference temperature: 1.1 s, 3- or 4-wire RTD: 920 ms, 2-wire RTD: 800 ms, Potentiometer: 2.05 s
Electrical isolation	
Input/Other circuits	basic insulation according to IEC 61010-1, rated insulation voltage 300 V _{eff}
Output/supply, programming input	functional insulation, rated insulation voltage 50 V AC There is no electrical isolation between the programming input and the supply. The programming cable provides galvanic isolation so that ground loops are avoided.
Directive conformity	
Electromagnetic compatibility	
Directive 2004/108/EC	EN 61326-1:2006
Conformity	
Electromagnetic compatibility	NE 21:2006
Degree of protection	IEC 60529:2001
Ambient conditions	
Ambient temperature	-20 ... 60 $^{\circ}\text{C}$ (-4 ... 140 $^{\circ}\text{F}$)
Mechanical specifications	
Degree of protection	IP20
Mass	approx. 130 g
Dimensions	20 x 119 x 115 mm (0.8 x 4.7 x 4.5 in) , housing type B2
Mounting	on 35 mm DIN mounting rail acc. to EN 60715:2001
General information	
Supplementary information	Statement of Conformity, Declaration of Conformity, Attestation of Conformity and instructions have to be observed where applicable. For information see www.pepperl-fuchs.com .

Release date 2014-04-30 14:09 Date of issue 2015-02-16 248760_eng.xml

Refer to "General Notes Relating to Pepperl+Fuchs Product Information".

Pepperl+Fuchs Group
www.pepperl-fuchs.com

USA: +1 330 486 0002
pa-info@us.pepperl-fuchs.com

Germany: +49 621 776 2222
pa-info@de.pepperl-fuchs.com

Singapore: +65 6779 9091
pa-info@sg.pepperl-fuchs.com

Accessories

Power feed module KFD2-EB2

The power feed module is used to supply the devices with 24 V DC via the Power Rail. The fuse-protected power feed module can supply up to 150 individual devices depending on the power consumption of the devices. A galvanically isolated mechanical contact uses the Power Rail to transmit collective error messages.

Power Rail UPR-03

The Power Rail UPR-03 is a complete unit consisting of the electrical inset and an aluminium profile rail 35 mm x 15 mm. To make electrical contact, the devices are simply engaged.

Profile Rail K-DUCT with Power Rail

The profile rail K-DUCT is an aluminum profile rail with Power Rail insert and two integral cable ducts for system and field cables. Due to this assembly no additional cable guides are necessary.



Power Rail and Profile Rail must not be fed via the device terminals of the individual devices!

K-CJC-**

This removable terminal block with integrated temperature measurement sensor is needed for internal cold junction compensation for thermocouples. One K-CJC-** is needed for each channel.

FACTware™

Device-specific drivers (DTM)

Adapter K-ADP-USB

Programming adapter for parameterisation via the serial USB interface of a PC/Notebook