



Model Number

OHV-CHARGER-B15

Charger for OHV200 with built-in Bluetooth modem

Function

The OHV-CHARGER-B15 charger allows you to charge the OHV200* handheld. The charger also includes a Bluetooth modem and a mini USB connection for transferring data.

Accessories

USB-G-1M-PVC-ABG-USBB-G

Adapter cable, USB to mini USB

ODZ-MAH-SUPPLY

Power supply

ODZ-MAH-5V-110V

Power supply

Dimensions

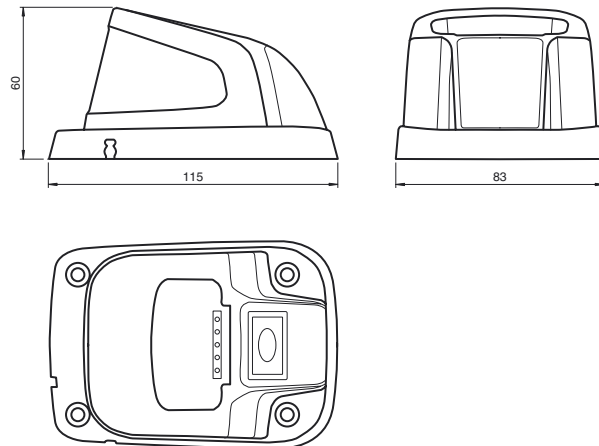

Technical data

General specifications

Transmitter frequency	2402 ... 2480 MHz
Emitted power	0.0007 W

Indicators/operating means

Operation indicator	LED green: supply
Function indicator	LED blue: Bluetooth connection
Switch	Bluetooth
Key	1 button

Electrical specifications

Operating voltage	U_B	5 V DC
Operating current		max. 1 A

Interface

Physical	Mini USB
----------	----------

Output

Output rated operating current	400 ... 1200 mA
Output voltage	5 V DC pulsing

Ambient conditions

Ambient temperature	-20 ... 55 °C (-4 ... 131 °F)
Storage temperature	-30 ... 65 °C (-22 ... 149 °F)

Mechanical specifications

Connection	Supply voltage: 5.5 mm hollow socket Interface : Mini USB
------------	--

Mass	approx. 139 g
Dimensions	115 mm x 83 mm x 60 mm

Compliance with standards and directives

Standard conformity

Electromagnetic compatibility	ETSI EN 301489-1:V1.9.2 ETSI EN 301489-17:V2.2.1 EN 61000-6-1:2007 EN 61000-6-2:2005/AC:2005 EN 61000-6-3:2007/A1:2011/AC:2012 EN 61000-6-4:2007/A1:2011
Safety	EN 60950-1:2006/A11:2009/A1:2010/A12:2011/AC:2011 EN 62311:2008
Radio spectrum	ETSI EN 300328:V1.7.1
Standards	EN 50581:2012

Approvals and certificates

FCC approval	FCC ID: QQ6-BTR11
--------------	-------------------