



$\lambda/4$  surge protection, N socket to N socket

### Features

- For broadband operation between 2 GHz and 6 GHz
- Space-saving, inline design
- N socket to N socket

### Dimensions

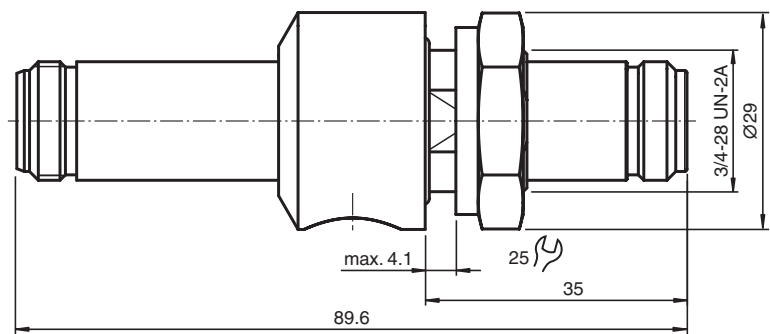

### Technical data

#### General specifications

Connection 1	socket
Construction type 1	straight
Threading 1	N
Connection 2	socket
Construction type 2	straight
Threading 2	N

#### Electrical specifications

Impedance	50 $\Omega$
Power loss	$\leq 0.2$ dB (at 2.4 GHz)
Operating frequency	2 ... 6 GHz

#### Standard conformity

Standards	IEC 61643-21
-----------	--------------

#### Ambient conditions

Operating temperature	-40 ... 85 °C (-40 ... 185 °F)
-----------------------	--------------------------------

#### Mechanical specifications

Protection degree	IP68 according to EN 60529
-------------------	----------------------------

#### Material

Contacts	CuBe alloy
Contact surface	gold-plated
Body	aluminum
Mass	80 g

### Mounting Instructions

The surge protector consists of a protected side and a non-protected side. The surge protector prevents surge currents from flowing from the non-protected area into the protected area.

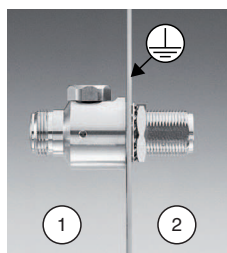

- 1 non-protected area
- 2 protected area

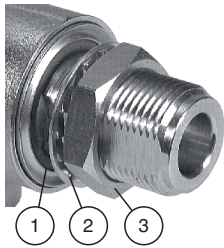
**Description:**

- 1 soft copper washer or O-ring
- 2 washer
- 3 mounting nut

According to IEC 62305 the integration of the surge protector is based on the lightning protection zone concept with bonding and shielding.

**Feed-Through Installation**

The protection zone principle favors the feed-through installation in a conductive and grounded panel, which is simultaneously the boundary to the higher protection zone containing the equipment to be protected. Note that if the panel is poorly grounded, additional grounding measures are necessary. We recommend that you place the surge protector at the line entrance into the structure or close to the equipment to be protected.

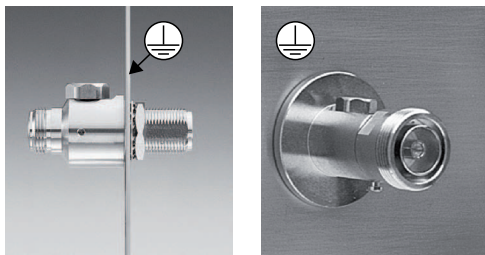
**Installation with Grounding Lug and Cable**

Alternatively, the surge protector can be connected to an equipotential bonding bar by means of a grounding lug and cable.

The grounding cable must meet the following requirements:

- min. cable size: AWG 6 / 16 mm<sup>2</sup>
- max. cable length: 0.5 m

**Mounting Torque for Mounting Nut**

- min. 35 Nm
- max. 44 Nm

**General Recommendations**

In order to keep the ground connection as short as possible, the surge protector should be grounded directly if possible.

All contact transitions must be clean and smooth.

Waterproof installations require suitable IEC / MIL conform counter connectors that must be tightened properly.

When tightening the cable connections, hold the surge protector using a spanner across the flats on the head of the surge protector.



Coupling nut torque must not exceed IEC standard or manufacturer specifications (IEC: max. 1.13 Nm). The bending moment created by connected cables must not exceed 1 Nm.

If exposed to extreme environmental conditions, especially icy conditions, or a polluted atmosphere, the surge protector should be covered with a self-vulcanising tape or a cold shrink tube.

If aluminum surge protectors are used with connectors made of copper-alloy base material and trimetal or nickel plating, the contact area must be taped to improve long-term durability.

When installing and grounding EMP protection components, the electrochemical potential between different metallic contacts should not exceed 250 mV (acc. to MIL-F-14072). If this value is exceeded, the contact area must be taped, coated, or sealed in order to minimize electrochemical corrosion.

Any liability or responsibility for the result of improper installation is disclaimed.

**Warning**

Disconnect or switch off in-line equipment during installation, maintenance, or disconnection of surge protectors. Keep back from such activities during thunderstorms.

Be aware that only a complete protection system according to IEC 62305-1 can protect your equipment and personnel.