

### Model Number

**IQC24-50F-T10**

Data carrier

### Features

- Operating frequency 13.56 MHz
- With extended temperature range up to 220 °C (428 °F)
- Conforms to ISO 15693
- 992 bytes memory freely available
- Readable and writable from both sides
- Protection degree IP67
- Mounting holes for simple installation

### Accessories

**ICZ-MH30-25-T10**

Spacers for code/data carrier

### Dimensions

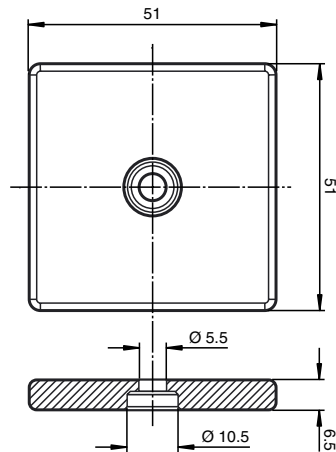

### Technical data

#### General specifications

Operating frequency	13.56 MHz
Transfer rate	26 kBit/s

#### Memory

Chip Type	my-d SRF 55V10P (Infineon)
Type/Size	EEPROM 992 Byte ROM 64 Bit
Read cycles	unlimited
Write cycles	> 100000
Data retention period	10 years at 55 °C (131 °F)

#### Ambient conditions

Ambient temperature	-40 ... 85 °C (-40 ... 185 °F)
Storage temperature	-40 ... 220 °C (-40 ... 428 °F)
Climatic conditions	100 % non-condensing

#### Mechanical specifications

Protection degree	IP67
Material	
Housing	PPS
Mass	25.7 g

#### Compliance with standards and directives

Directive conformity	
R&TTE Directive 1995/5/EC	EN 300330-2:2010 V1.5.1
Standard conformity	
Electromagnetic compatibility	EN 300330-1:2010 V1.7.1 EN 300330-2:2010 V1.5.1
Protection degree	EN 60529:2000
RFID	ISO/IEC 15693-1:2010 , ISO/IEC 15693-2:2006 , ISO/IEC 15693-3:2009 , ISO/IEC 18000-3:2010

### Notes

The transponder can be read and written from either side.

### Notes

High temperatures will cause the enclosure to stretch.

If the enclosure is assembled under mechanical stress, the resulting pressure may damage the data carrier.

Install the enclosure loosely to allow for expansion.