



Model Number

DoorScan-I

Sensor module, interface

Features

- Sensor module for configurable DoorScan® presence sensor
- Multi-function interface with full operation
- Complete system supply for the entire system for one door
- Can also be used to supply the emitter and receiver modules with power
- Single button commissioning with automatic Teach-in function
- SIL2, certified in accordance with DIN 18650/EN 16005
- Tool-free module mounting using snap-in mechanism
- Switchable NPN or PNP outputs

Dimensions

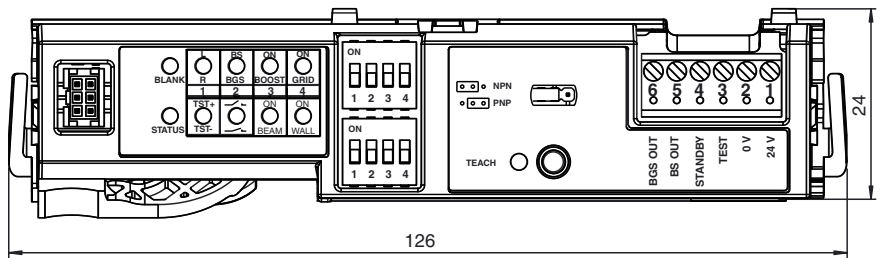

Electrical connection

1	BN	— 24V
2	BU	— 0V
3	GY	— TEST
4	PK	— STANDBY
5	BK	— BS OUT
6	WH	— BGS OUT

Indicators/operating means

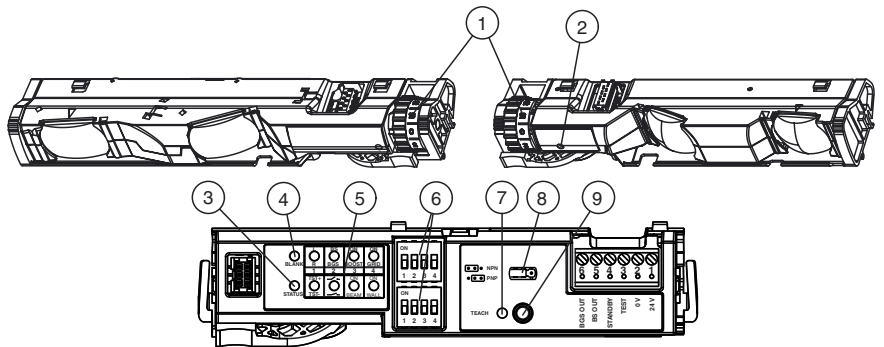

- | | |
|------------------------------|--------------------------------|
| 1 Einstellrad Neigungswinkel | 6 DIP-Schalter - Reihe 1 und 2 |
| 2 Anzeige Empfänger LED rot | 7 Teach-LED gelb |
| 3 Status-LED rot | 8 Jumper |
| 4 Blank-LED grün | 9 Teach-Taste |
| 5 DIP-LEDs grün | |

Release date: 2015-03-10 16:36 Date of issue: 2015-03-10 265644_eng.xml

Refer to "General Notes Relating to Pepperl+Fuchs Product Information".

Pepperl+Fuchs Group
www.pepperl-fuchs.com

USA: +1 330 486 0001
fa-info@us.pepperl-fuchs.com

Germany: +49 621 776 4411
fa-info@de.pepperl-fuchs.com

Singapore: +65 6779 9091
fa-info@sg.pepperl-fuchs.com

Technical data

General specifications

Operating mode	Background evaluation
----------------	-----------------------

Functional safety related parameters

Safety Integrity Level (SIL)	SIL 2
Performance level (PL)	PL d
Category	Cat. 2
MTTF _d	2716 a
Mission Time (T _M)	20 a
Diagnostic Coverage (DC)	90 %

Indicators/operating means

Function indicator	Interface: Red LED: detection, excess gain, fault code Yellow LED: teach status Green LED: blank status Green LED: DIP switch status
--------------------	---

Electrical specifications

Operating voltage	U _B	24 V DC +/- 20 %
No-load supply current	I ₀	30 mA

Input

Test input	high level ≥ 15 V low level ≤ 2 V
Control input	Standby active at U = 11 V DC at 30 V DC

Output

Switching type	light on
Signal output	switchable NPN or PNP , short-circuit protected
Switching voltage	max. 30 V DC
Switching current	max. 100 mA
Response time	≤ 52 ms ≤ 200 ms in boost operating mode

Ambient conditions

Ambient temperature	-30 ... 60 °C (-22 ... 140 °F)
---------------------	--------------------------------

Mechanical specifications

Mounting height	max. 3500 mm
Degree of protection	IP54 (iwhen mounted)
Connection	plug strip , 6-pin
Mass	approx. 30 g

Compliance with standards and directives

Directive conformity	
Machinery Directive 2006/42/EC	EN 12978:2003+A1:2009 EN ISO 13849-1:2008 + AC:2009 EN 16005:2012 Chapter 4.6.8
EMC Directive 2004/108/EC	EN 61000-6-2:2005 EN 61000-6-3:2007+A1:2011
Standard conformity	
Standards	EN 61508-1:2010 DIN 18650-1:2010 Chapter 5.7.4 BS 7036-1:1996 Chapter 7.3.2 BS 7036-2:1996 Chapter 8.1

Approvals and certificates

CCC approval	CCC approval / marking not required for products rated ≤36 V
--------------	--

Accessories

DoorScan Cable BS/BGS

Connecting cable for transition from hinge side to leading edge side

DoorScan Transfer Loop

Door transition cable to door controller for DoorScan® sensor, including cable sheathing and strain relief

DoorScan Connection Cable 5p

Connecting cable with 5 plug-in connections for DoorScan®-I/-T/-R modules

DoorScan Adapter

Adapter module for installation in the DoorScan® and TopScan sensor profile, multifunction interface module

DoorScan Cable Adapter

Adapter module for installation in the DoorScan® and TopScan sensor profile, multifunction interface module

Other suitable accessories can be found at www.pepperl-fuchs.com

Release date: 2015-03-10 16:36 Date of issue: 2015-03-10 265644_eng.xml

Additional Information

Layout of the sensor system for a door (door hinge side/hinge opposite side)

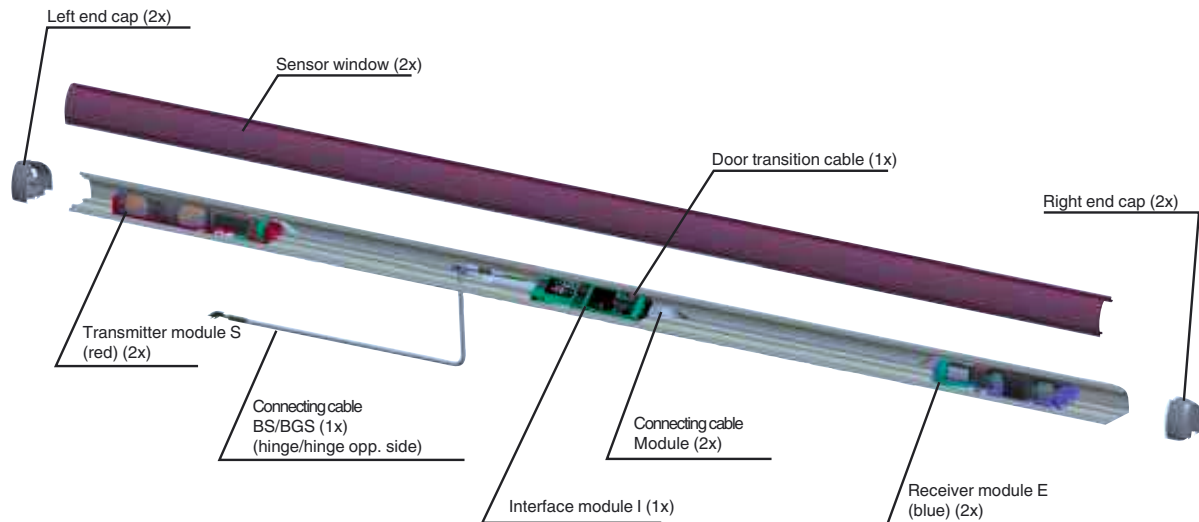

Standby

When the supply voltage is applied, the sensor is put into standby; the energy consumption is reduced to less than 80% in this state. Once the signal is deactivated, the sensor is immediately ready for operation and enables the signal outputs within 52 ms and/or 200 ms (in boost operating mode) if the detection field is free.

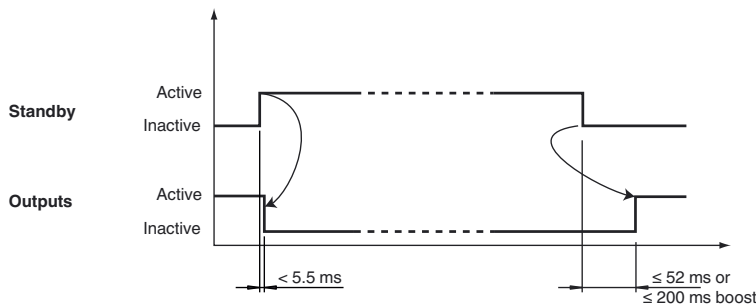

Test input circuit

DoorScan test input circuit

Test Function	Test inactive	Test active	Interface, bottom row, Dip switch 1 and 2
High active			
Low active			
High inactive			
Low inactive			

Test signal

The signal outputs enable crossed circuit detection. To do so, the outputs carry out a delayed shutoff from each other (see signal curve).

Release date: 2015-03-10 16:36 Date of issue: 2015-03-10 265644_eng.xml

**Note!**

The test signal must be in contact with the test input for at least 9 ms!

The duration of the test signal must not exceed 0.5 s, otherwise this will deactivate the sensor.

Operating modes**Boost operating mode**

Activation with dark floors, even at high installation heights (increased sensitivity). In these cases, the response time of the sensor is increased from 50 ms to 200 ms. If necessary, the speed of the door must be adjusted to the response time.

Grid operating mode

Activation in the event of faults due to metal grating on the ground. Used where metal grating and shafts are present in the detection field.

BEAM

Off: outer beams normal

On: outer beams at an angle (factory setting)

You can switch off the beams extending beyond the emitter modules manually to avoid detection of deep door jambs.

WALL

Off: automatic wall suppression not active

On: automatic wall suppression active (factory setting)

If the door panel does not open against a wall, you can switch off wall suppression to accelerate the commissioning process. Metal grating mode is improved if receiver modules are used from device version V.03 onward.