

Model Number

LAGERBOCK AIR16

Pedestal for the sensor module AIR16

Dimensions

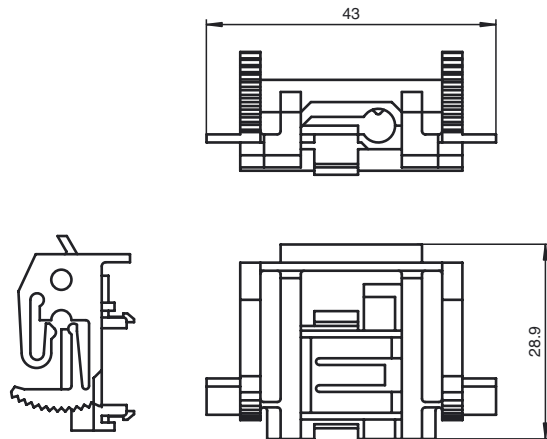

Technical data

Mechanical specifications

| | |
|----------|-------------|
| Material | plastic |
| Mass | approx. 5 g |

Suitable series

| | |
|--------|---------|
| Series | TopScan |
|--------|---------|

Indicators / operating means

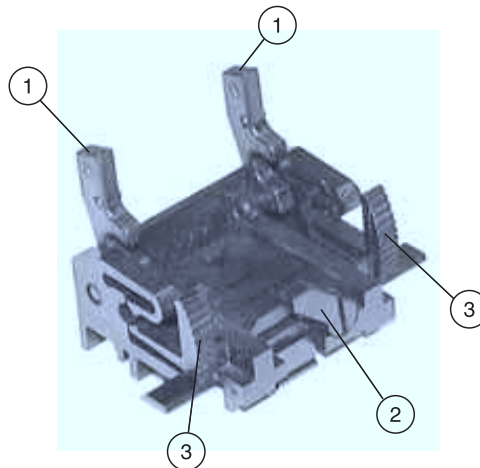

- 1 Locking mechanism for replacing and fastening the AIR16 sensor module
- 2 Locking mechanism for positioning and fastening in the Topscan aluminium profile
- 3 Adjuster for stepless angle adjustment of the sensor monitoring edge

Replacing AIR16 sensors for Topscan device

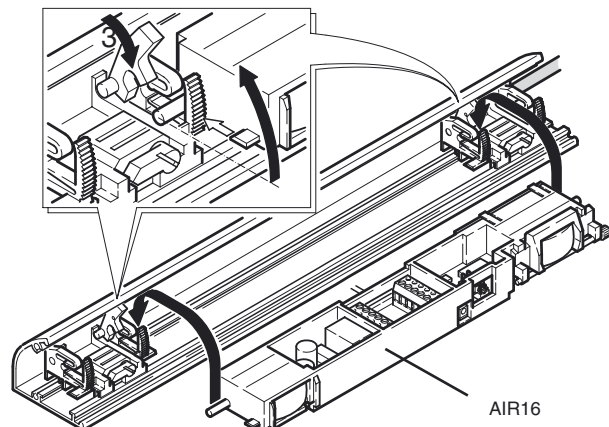

Sensors can be replaced faster and more easily with the locking mechanism on the print holder.

Release date: 2013-09-24 09:48 Date of issue: 2013-09-24 406730_eng.xml

