



Model Number

UP-Einbaurahmen

Mounting frame for sensors in the AIR30 and PROSCAN series

Dimensions

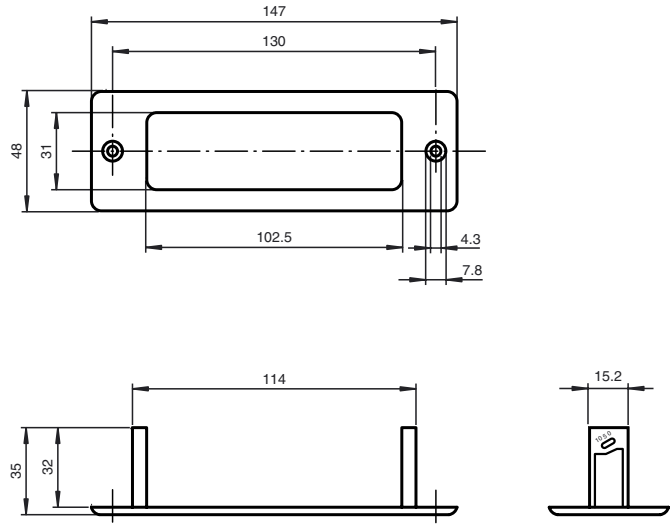

Technical data

Mechanical specifications

Material	plastic
Mass	approx. 15 g

Suitable series

Series	AIR30 Proscan
--------	------------------

Mechanical arrangement

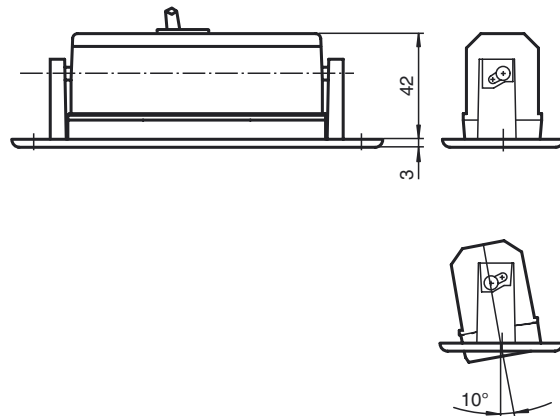

Release date: 2012-03-07 09:32 Date of issue: 2012-03-07 413567_eng.xml

Subject to modifications without notice

Pepperl+Fuchs Group
www.pepperl-fuchs.com

USA: +1 330 486 0001
fa-info@us.pepperl-fuchs.com

Germany: +49 621 776-4411
fa-info@pepperl-fuchs.com

Copyright Pepperl+Fuchs
Singapore: +65 6779 9091
fa-info@sg.pepperl-fuchs.com