

Model Number

PROSCAN/38a

Active infrared scanner
with fixed cable

Features

- Fan-shaped detection field with up to 12 beams
- Closing safety monitoring over the complete door width
- Adjustable detection fields for different door widths
- Automatic drift compensation

Product information

The compact ProScan energetic light scanner operates using an integrated source of infrared light and creates a fan-shaped detection field consisting of a maximum of 12 independent light beams. Since the beam intensifies toward the center of the fan, the area around the closing edges in particular is monitored virtually seamlessly. The sensors are self-programming and automatically adapt to any environment, learn the environment, and even automatically adapt to subsequent changes. Other notable features include the high level of sensitivity, ambient light immunity and compensation of long-term drift. This function guarantees reliable long-term use, even in dirty, rainy or snowy conditions.

Release date: 2012-05-30 16:33 Date of issue: 2012-08-03 419564_eng.xml

Dimensions

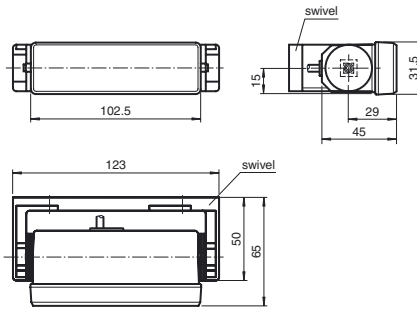

Mounting dimensions for swivel

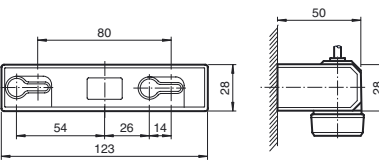

Mounting dimensions with mounting bracket set AIR30

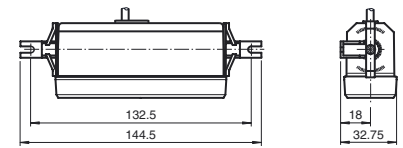

Electrical connection

Option:

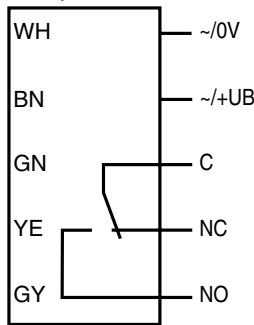

Indicators/operating means

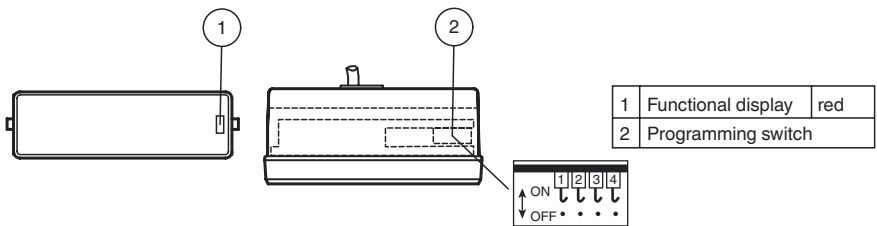

Technical data

General specifications

| | |
|----------------------|--|
| Detection field | total field: 2300 mm x 80 mm left/right field: 1150 mm x 80 mm center field: 1000 mm x 80 mm II (installation height: 2 m) |
| Light source | 12 x IRED |
| Light type | modulated infrared light |
| Teach-in time | approx. 4 s |
| Open time | 3 min/10 s, programmable |
| Accessories provided | Swivel bracket, Mounting bracket |

Functional safety related parameters

| | |
|--------------------------------|-------|
| MTTF _d | 780 a |
| Mission Time (T _M) | 20 a |
| Diagnostic Coverage (DC) | 60 % |

Indicators/operating means

| | |
|------------------|--|
| Function display | LED red: on for object detection, flashes during teaching phase |
| Controls | Programmable switch for switching type, open time, detection field |

Electrical specifications

| | | |
|------------------------|----------------|---------------------------------|
| Operating voltage | U _B | 12 ... 38 V DC / 12 ... 28 V AC |
| Ripple | | 10 % |
| No-load supply current | I ₀ | 100 mA |
| Power consumption | P ₀ | 3 VA |

Output

| | | |
|--------------------|---------------------------------------|--------|
| Switching type | Output active / inactive programmable | |
| Signal output | Relay, 1 alternator | |
| Switching voltage | 48 V DC | |
| Switching current | 1 A at 24 V DC | |
| Response time | < 50 ms | |
| De-energized delay | t _{off} | 200 ms |

Ambient conditions

| | |
|---------------------|-------------------------------|
| Ambient temperature | -20 ... 60 °C (-4 ... 140 °F) |
| Storage temperature | -20 ... 70 °C (-4 ... 158 °F) |

Mechanical specifications

| | |
|-------------------|------------------|
| Mounting height | 1000 ... 2500 mm |
| Protection degree | IP52 |
| Connection | 5 m fixed cable |
| Material | |
| Housing | ABS |
| Optical face | PMMA |
| Mass | approx. 100 g |

Curves/Diagrams

Timing diagram Proscan

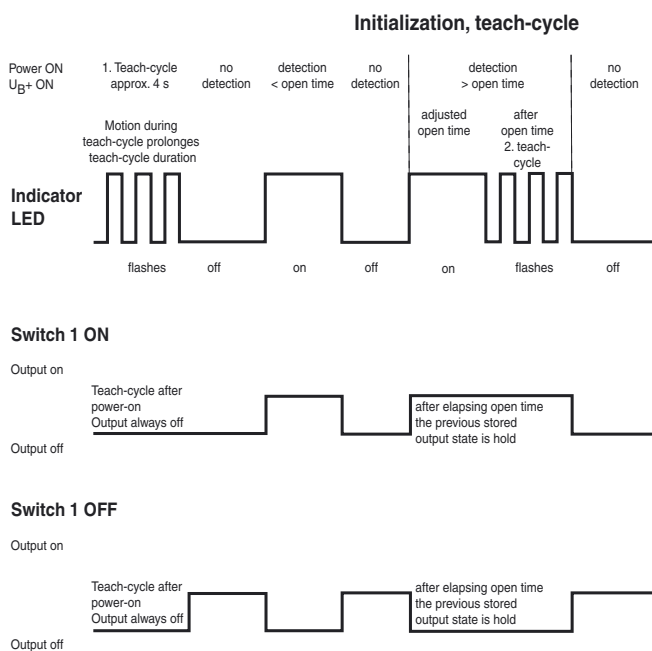

Typical applications

- Closing edge protection on automatic sliding doors, for example sliding doors in shopping centers, public buildings and office buildings
- Version T with e1 approval: Closing edge protection on automatic doors on public transport vehicles, such as buses and trains
- Threshold monitoring on revolving doors

Detection area

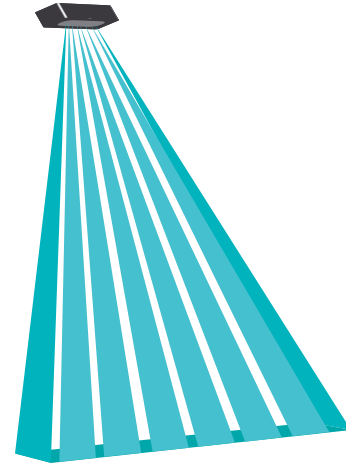

Accessories

UP-Einbaurahmen

Mounting frame for sensors in the AIR30 and PROSCAN series

Other suitable accessories can be found at www.pepperl-fuchs.com

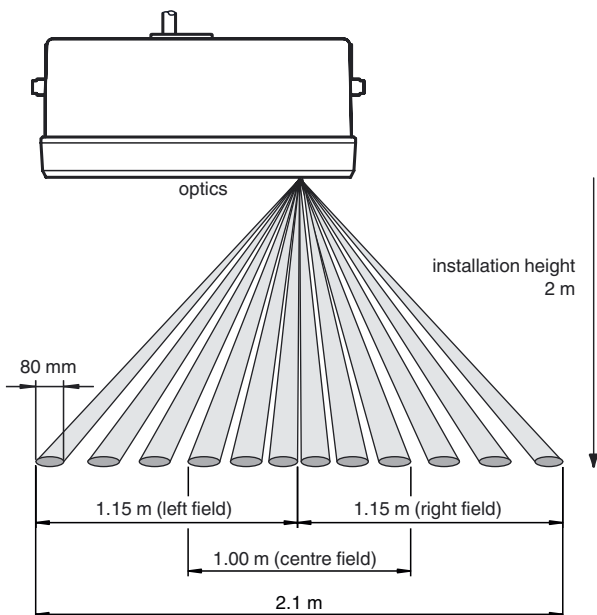

Functional principle

The ProScan is a 12-beam energetic light scanner based on the principles of active infrared. The beams, which are switched independently, enable the sensor to fan out across an extremely wide and narrow detection field in the area of the door.

The clearly defined, fan-shaped detection field on the ProScan can be set manually in four areas: half fan to the right, half fan to the left, central fan and full detection field.

Immediately after being switched on for the first time, the ProScan programs the reflected pattern of the detected background as the reference signal. During this process, the ProScan automatically adapts to the relevant installation and assembly environment. Since each of the individual light beams on the ProScan independently programs its specific reception level, there is no need to manually configure complex sensitivity settings.

Once the programming phase is complete, the light reflected from each of the 12 light beams is evaluated. Each time there is a difference between the reflected value of an individual light beam and the reference signal, a switching process is initiated.

"Open Time" Function

The ProScan is a self-programming device, and automatically adjusts to changes in its environment. If the ProScan detects a stationary object that does not correspond to the programmed reference signal (for example, a suitcase), ProScan interprets this as a permanent change in the environment and initiates a new self teach-in process after a preset time (referred to as "Open Time") has elapsed. Open Time can be adjusted to meet customer application requirements.

"Suitcase" Function

After a background has been changed, the ProScan "Suitcase" function allows the reference to be adjusted back to the original background. Once a self-taught object, such as a suitcase, is removed from the detection field again, ProScan returns to the original reference. A new learning process is not required.

Compensating for long-term drifts

The ProScan is able to compensate for long-term drifts. Using this function, changes to the ground reflectance (for example, caused by rain or snow), as well as temperature fluctuations and dirt on the optical surface or ground are automatically compensated for.

Test input (optional)

Using the integrated test input, the overall function of the ProScan can be reliably checked by testing all 12 light beams simultaneously.

Programming options

The programming switch can be accessed by gently pulling the lens assembly away from the housing. A small flat-head screwdriver can be used to gently push the cover off by the slots located at the sides of the cover.

Each switch is activated when the pin is connected to the hook (ON); if the pin is not connected to the hook, the switch is deactivated (OFF).

The programming options are listed in the following table.

| Switches | Output active during detection | Output inactive during detection | Open Time 10 seconds | Open Time PROSCAN 3 min PROSCAN-T 3 seconds |
|----------|--------------------------------|----------------------------------|----------------------|--|
| 1 | ON | OFF | | |
| 2 | | | ON | OFF |

Release date: 2012-05-30 16:33 Date of issue: 2012-08-03 419564_eng.xml



| Detecting field at installation height of 2000 mm | | | | |
|---|-------------------------------|-------------------------------|--------------------------------|---------------------------------|
| Switches | 2300 mm x 80 mm Full field | 1150 mm x 80 mm Left field | 1150 mm x 80 mm Right field | 1000 mm x 80 mm Center field |
| 3 | OFF | OFF | ON | ON |
| 4 | OFF | ON | OFF | ON |

Release date: 2012-05-30 16:33 Date of issue: 2012-08-03 419564_eng.xml