

**Model Number**

**PROSCAN-2597/38a/76a**

Active infrared scanner  
with fixed cable

**Features**

- Fan-shaped detection field with up to 12 beams
- Closing safety monitoring over the complete door width
- Adjustable detection fields for different door widths
- Automatic drift compensation
- Version with test input
- Version with increased sensitivity in midfield
- Version with a single automatic teach

**Product information**

The compact ProScan energetic light scanner operates using an integrated source of infrared light and creates a fan-shaped detection field consisting of a maximum of 12 independent light beams. Since the beam intensifies toward the center of the fan, the area around the closing edges in particular is monitored virtually seamlessly. The sensors are self-programming and automatically adapt to any environment, learn the environment, and even automatically adapt to subsequent changes. Other notable features include the high level of sensitivity, ambient light immunity and compensation of long-term drift. This function guarantees reliable long-term use, even in dirty, rainy or snowy conditions.

**Dimensions**

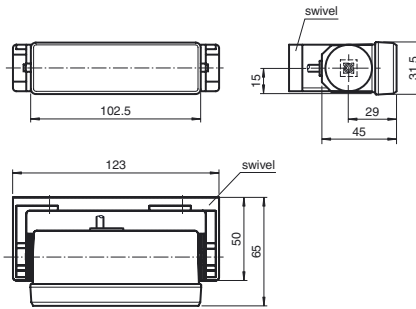

Mounting dimensions for swivel

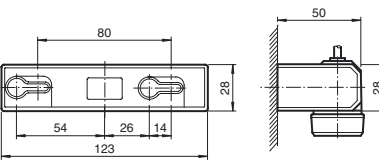

Mounting dimensions with mounting bracket set AIR30

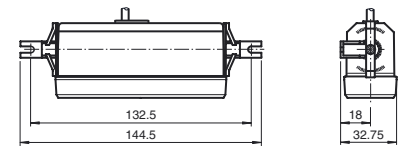

**Electrical connection**

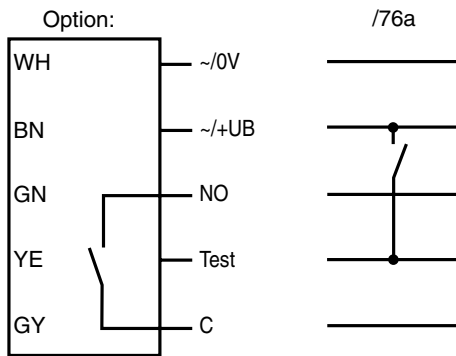

**Note:**  
Test input can not be used, if sensor is supplied with AC voltage!

**Indicators/operating means**

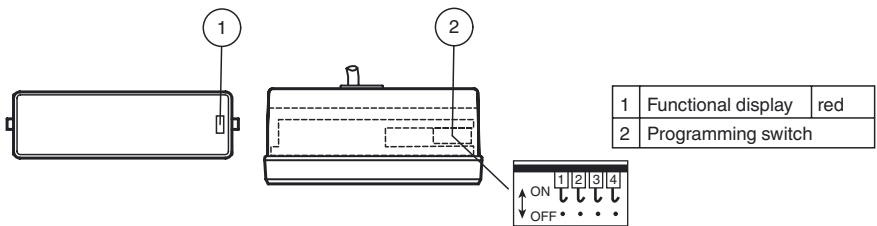

Release date: 2012-05-30 16:32 Date of issue: 2012-08-03 420852\_eng.xml

Subject to modifications without notice

Pepperl+Fuchs Group  
www.pepperl-fuchs.com

USA: +1 330 486 0001  
fa-info@us.pepperl-fuchs.com

Germany: +49 621 776-4411  
fa-info@pepperl-fuchs.com

Copyright Pepperl+Fuchs  
Singapore: +65 6779 9091  
fa-info@sg.pepperl-fuchs.com

## Technical data

### General specifications

Detection field	total field: 2300 mm x 80 mm left/right field: 1150 mm x 80 mm center field: 1000 mm x 80 mm II (installation height: 2 m)
Light source	12 x IRED
Light type	modulated infrared light
Teach-in time	approx. 4 s
Accessories provided	Swivel bracket, Mounting bracket

### Functional safety related parameters

MTTF <sub>d</sub>	780 a
Mission Time (T <sub>M</sub> )	20 a
Diagnostic Coverage (DC)	60 %

### Indicators/operating means

Function display	LED red: on for object detection, flashes during teaching phase
Controls	Programmable switch for switching type and detection field

### Electrical specifications

Operating voltage	U <sub>B</sub>	12 ... 38 V DC
Ripple		10 %
No-load supply current	I <sub>0</sub>	100 mA
Power consumption	P <sub>0</sub>	3 VA

### Input

Test input	emitter deactivation with +U <sub>B</sub>
------------	---

### Output

Switching type	Output active / inactive programmable	
Signal output	relay, 1 NO	
Switching voltage	48 V DC	
Switching current	1 A at 24 V DC	
Response time	< 50 ms	
De-energized delay	t <sub>off</sub>	200 ms

### Ambient conditions

Ambient temperature	-20 ... 60 °C (-4 ... 140 °F)
Storage temperature	-20 ... 70 °C (-4 ... 158 °F)

### Mechanical specifications

Mounting height	1000 ... 2500 mm
Protection degree	IP52
Connection	5 m fixed cable
Material	
Housing	ABS
Optical face	PMMA
Mass	approx. 100 g

## Curves/Diagrams

### Timing diagram Proscan

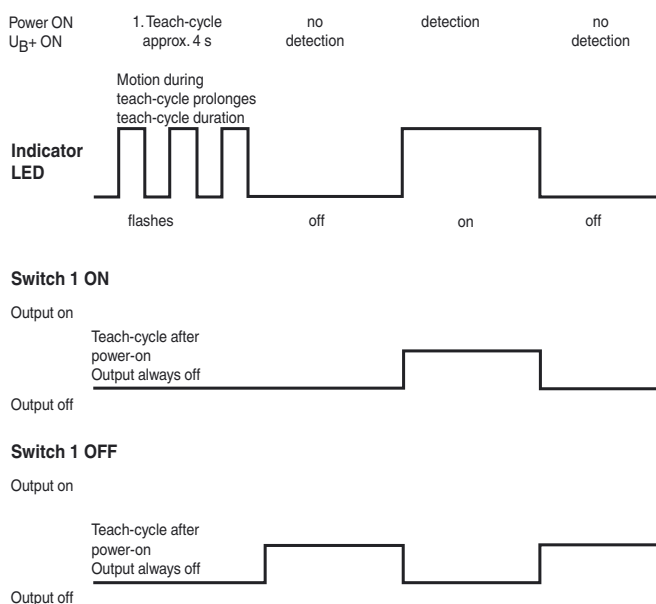

## Typical applications

- Closing edge protection on automatic sliding doors, for example sliding doors in shopping centers, public buildings and office buildings
- Version T with e1 approval: Closing edge protection on automatic doors on public transport vehicles, such as buses and trains
- Threshold monitoring on revolving doors

## Detection area



## Accessories

### UP-Einbaurahmen

Mounting frame for sensors in the AIR30 and PROSCAN series

Other suitable accessories can be found at [www.pepperl-fuchs.com](http://www.pepperl-fuchs.com)

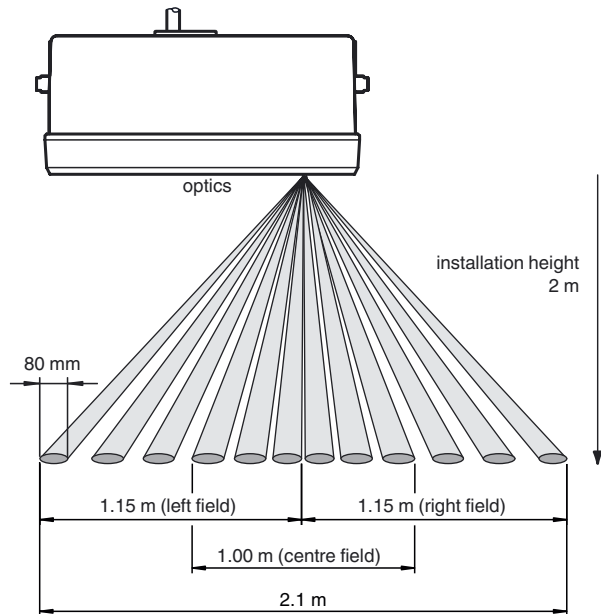

### Functional principle

The ProScan is a 12-beam energetic light scanner based on the principles of active infrared. The beams, which are switched independently, enable the sensor to fan out across an extremely wide and narrow detection field in the area of the door.

The clearly defined, fan-shaped detection field on the ProScan can be set manually in four areas: half fan to the right, half fan to the left, center fan and full detection field.

Immediately after being switched on for the first time, the ProScan programs the light pattern of the detected background as the reference signal. During this process, the ProScan automatically adapts to the application environment. As each of the individual light beams on the ProScan stores its specific received light level automatically, there is no need to configure complex manual sensitivity settings.

Once the programming phase is complete, the light reflected from each of the 12 light beams is evaluated. Each time there is a difference between the reflected value of an individual light beam and the reference signal, a switching process is initiated.

#### Compensating for Long-Term Drifts

The ProScan is able to compensate for long-term drifts. Using this function, changes to the ground reflectance, caused by rain or snow for example, as well as temperature fluctuations and dirt on the optical surface or ground are automatically compensated for.

#### Test Input (Optional)

Using the integrated test input, the overall function of the ProScan can be reliably checked by testing all 12 light beams simultaneously.

### Programming options

The programming switch can be accessed by gently pulling the lens assembly away from the housing. A small flat-head screwdriver can be used to gently push the cover off by the slots located at the sides of the cover.

Each switch is activated when the pin is connected to the hook (ON); if the pin is not connected to the hook, the switch is deactivated (OFF).

The programming options are listed in the following table.

Switches	Output active during detection		Output inactive during detection	
1	ON		OFF	
<b>Detecting field at installation height of 2000 mm</b>				
Switches	2300 mm x 80 mm Full field	1150 mm x 80 mm Left field	1150 mm x 80 mm Right field	1000 mm x 80 mm Center field
3	OFF	OFF	ON	ON
4	OFF	ON	OFF	ON

Release date: 2012-05-30 16:32 Date of issue: 2012-08-03 420852\_eng.xml