

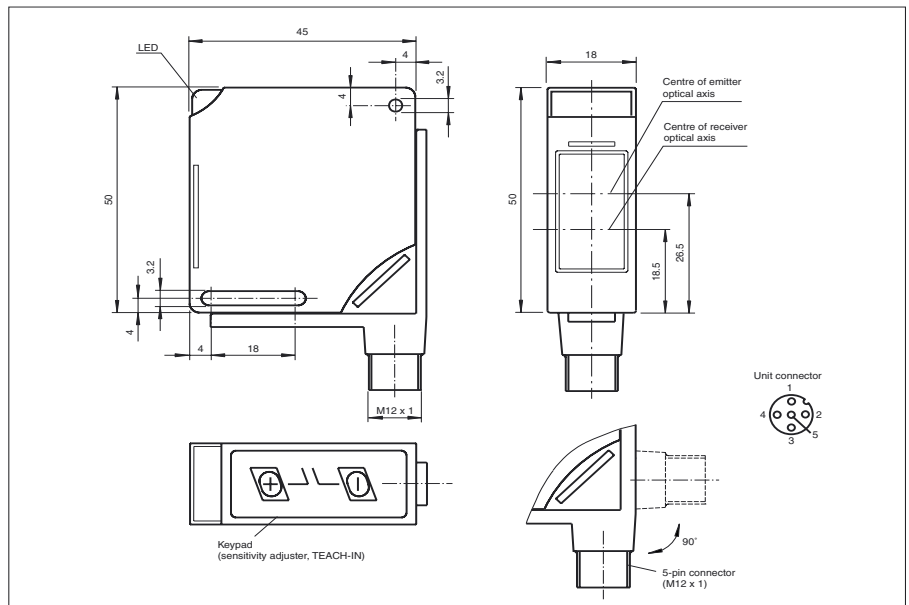

## Dimensions



## Model Number

### MLV11-54-G/47/112

Retro-reflective sensor with polarisation filter for glass detection with 5-pin M12 connector, 90° adjustable position

## Features

- Detection range up to 3 m
- Detection of transparent objects, i.e. clear glass, PET and transparent foils
- Glare protected with polarisation filter
- Visible red light
- Pre-fault indication and output (dynamic and static)
- Automatic adjustment of sensitivity per Teach-In
- Parameterisation via optical communication link (e.g. optional time increments)
- Protection degree IP68
- All materials approved for food industry applications
- Multifunction input

## Electrical connection

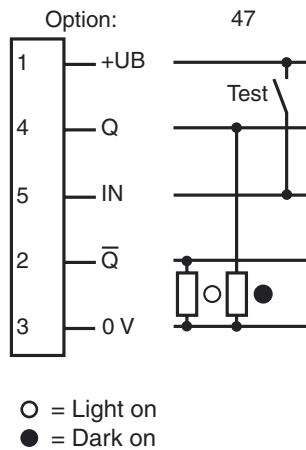

**Technical data****General specifications**

Effective detection range	0.1 ... 2 m
Reflector distance	600 ... 3000 mm
Threshold detection range	3 m
Light source	LED
Approvals	CE
Reference target	H60 reflector
Light type	red, modulated light
Diameter of the light spot	100 mm at a distance of 3000 mm
Ambient light limit	10000 Lux

**Indicators/operating means**

Operating display	LED green
Function display	Teach-In: LED green flashing switching state: LED yellow pre-fault indicator: LED red flashing
Operating elements	membrane keys for setting sensitivity and Teach-In

**Electrical specifications**

Operating voltage	10 ... 30 V DC
Ripple	10 %
No-load supply current	$I_0 \leq 25 \text{ mA}$
Time delay before availability	$t_v \leq 80 \text{ ms}$

**Input**

Test input	inactive: $\leq 3 \text{ V}$ or unwired; active: $\geq 7 \text{ V}$
------------	---

**Output**

Output of the pre-fault indication	pnp, dynamic/static configurable
Switching type	light/dark switching
Signal output	2 switch outputs pnp, parameterisable as - NO/NC (antivalent) - NO and pre-fault indication - NC and pre-fault indication
Switching voltage	max. 30 V DC
Switching current	max. 200 mA
Voltage drop	$U_d \leq 2.5 \text{ V}$
Switching frequency	$f \leq 1000 \text{ Hz}$
Response time	$\leq 0.5 \text{ ms}$
Timer function	parameterisable

**Standard conformity**

Standards	EN 60947-5-2
-----------	--------------

**Ambient conditions**

Ambient temperature	-25 ... 70 °C (248 ... 343 K)
Storage temperature	-40 ... 70 °C (233 ... 343 K)

**Mechanical specifications**

Protection degree	IP68
Connection	5-pin M12 x 1 connector, 90° adjustable position
Material	
Housing	PBT
Optical face	scratch resistant plastic pane
Mass	60 g

**Curves/Diagrams**