



### Model Number

AVS58N-011YYRYGN-0014

### Features

- Industrial standard housing Ø58 mm
- 14 Bit singleturn
- Hardware encoder
- Data transfer up to 2 MBaud
- Optically isolated RS 422 interface
- Clamping flange

### Description

This singleturn absolute encoder with modern fast technology transmits a position value corresponding to the shaft setting via the SSI interface (Synchronous Serial Interface). The resolution of the AVS58 is maximum 16384 steps per revolution.

In contrast to the AVS58 series the encoder does not have a microcontroller. Thus, it is a pure hardware encoder.

The control module sends a clock bundle to the absolute encoder to obtain the position data. The rotary encoder then sends the position data synchronous to the cycles of the control module.

This singleturn absolute encoder is available in clamp flange design with a shaft diameter of 10 mm x 20 mm. The electrical connection is made by a 12-pin round plug connector.

### Technical data

#### Functional safety related parameters

MTTF <sub>d</sub>	170 a
Mission Time (T <sub>M</sub> )	20 a
L <sub>10h</sub>	1.9 E+11 at 6000 rpm and 20/40 N axial/radial shaft load
Diagnostic Coverage (DC)	0 %

#### Electrical specifications

Operating voltage U <sub>B</sub>	5 V DC
No-load supply current I <sub>0</sub>	max. 120 mA
Linearity	± 2 LSB at 14 Bit, ± 1 LSB at 13 Bit, ± 0,5 LSB at 12 Bit
Output code	Gray code
Code course (counting direction)	cw descending (clockwise rotation, code course descending)

#### Interface

Interface type	SSI
Monoflop time	20 ± 10 µs
Resolution	
Single turn	up to 14 Bit
Overall resolution	up to 14 Bit
Transfer rate	0.1 ... 2 MBit/s
Standard conformity	RS 422

#### Connection

Connector	type 9416L, 12-pin
-----------	--------------------

#### Standard conformity

Protection degree	DIN EN 60529, IP65
Climatic testing	DIN EN 60068-2-3, no moisture condensation
Emitted interference	EN 61000-6-4:2007
Noise immunity	EN 61000-6-2:2005
Shock resistance	DIN EN 60068-2-27, 100 g, 3 ms
Vibration resistance	DIN EN 60068-2-6, 10 g, 10 ... 2000 Hz

#### Ambient conditions

Operating temperature	-40 ... 85 °C (-40 ... 185 °F)
Storage temperature	-40 ... 85 °C (-40 ... 185 °F)

#### Mechanical specifications

Material	housing: powder coated aluminium flange: aluminium shaft: stainless steel
Mass	approx. 460 g
Rotational speed	max. 12000 min <sup>-1</sup>
Moment of inertia	50 gcm <sup>2</sup>
Starting torque	< 5 Ncm
Shaft load	
Axial	40 N
Radial	110 N

**Dimensions**

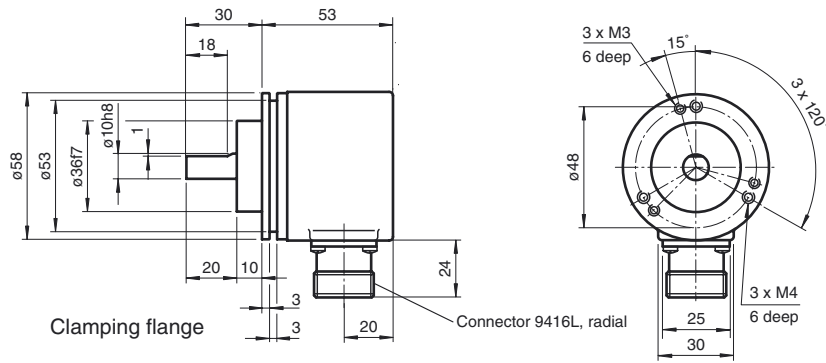

**Accessories**

**9416L**  
Cable connector

## Electrical connection

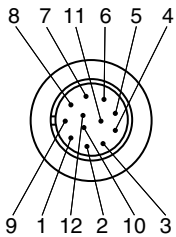
Signal	Connector 9416L, 12-pin	Explanation	Pinout
GND (encoder)	12	Power supply	
U <sub>b</sub> (encoder)	10	Power supply	
Clock (+)	2	Positive cycle line	
Clock (-)	1	Negative cycle line	
Data (+)	3	Positive transmission data	
Data (-)	4	Negative transmission data	
Reserved	11	Not wired, reserved	
Reserved	5	Not wired, reserved	
Reserved	9	Not wired, reserved	
Reserved	8	Not wired, reserved	
Reserved	6	Not wired, reserved	
Reserved	7	Not wired, reserved	

## Description

The Synchronous Serial Interface was specially developed for transferring the output data of an absolute encoder to a control device. The control module sends a clock bundle and the absolute encoder responds with the position value.

Thus only 4 lines are required for the clock and data, no matter what the resolution of the rotary encoder is. The RS 422 interface is optically isolated from the power supply.

## SSI signal course Standard

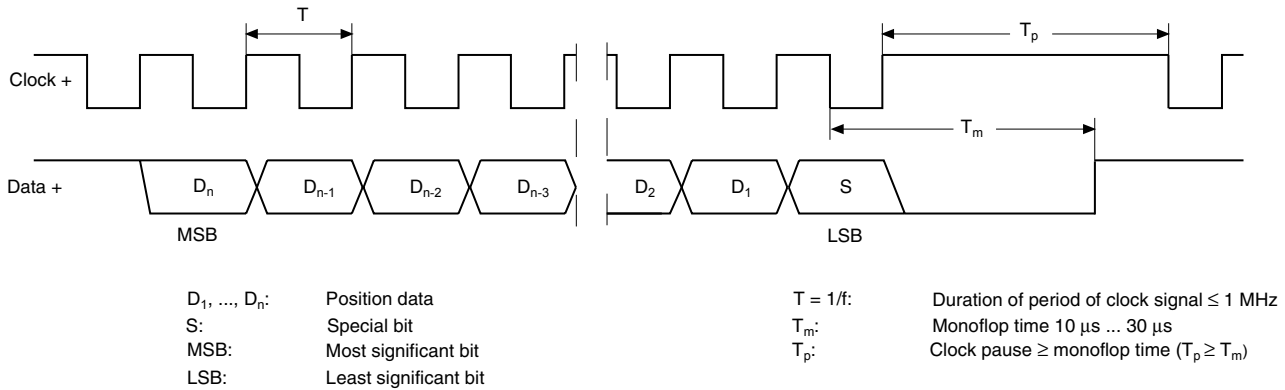

## SSI output format Standard

- At idle status signal lines "Data +" and "Clock +" are at high level (5 V).
- The first time the clock signal switches from high to low, the data transfer in which the current information (position data ( $D_n$ ) and special bit (S)) is stored in the encoder is introduced.
- The highest order bit (MSB) is applied to the serial data output of the encoder with the first rising pulse edge.
- The next successive lower order bit is transferred with each following rising pulse edge.
- After the lowest order bit (LSB) has been transferred the data line switches to low until the monoflop time  $T_m$  has expired.
- No subsequent data transfer can be started until the data line switches to high again or the time for the clock pause  $T_p$  has expired.
- After the clock sequence is complete, the monoflop time  $T_m$  is triggered with the last falling pulse edge.
- The monoflop time  $T_m$  determines the lowest transmission frequency.

## SSI output format ring slide operation (multiple transmission)

- In ring slide operation, multiple transmission of the same data word over the SSI interface makes it possible to offer the possibility of detecting transmission errors.
- In multiple transmission, 25 bits are transferred per data word in standard format.
- If the clock change is not interrupted after the last falling pulse edge, ring slide operation automatically becomes active. This means that the information that was stored at the time of the first clock change is generated again.
- After the first transmission, the 26<sup>th</sup> pulse controls data repetition. If the 26<sup>th</sup> pulse follows after an amount of time greater than the monoflop time  $T_m$ , a new current data word will be transmitted with the following pulses.



If the pulse line is exchanged, the data word is generated offset.  
Ring slide operation is possible up to max. 13 bits.

**Block diagram**

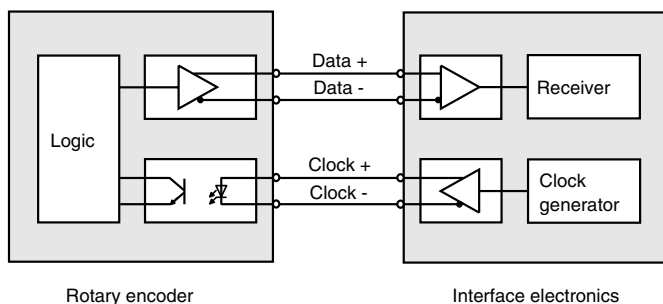

**Line length**

Line length in m	Baudrate in kHz
< 50	< 400
< 100	< 300
< 200	< 200
< 400	< 100

**Accessories**

Accessories	Name/defining feature	Order code
Couplings	D1: Ø10 mm, D2: Ø10 mm	9401
	D1: Ø10 mm, D2: Ø10 mm	9404
	D1: Ø10 mm, D2: Ø10 mm	9409
	D1: Ø10 mm, D2: Ø10 mm	KW
Measurement wheels with circumference of 500 mm	Plastic	9101, 10
	Pimpled rubber	9102, 10
	Knurled aluminium	9103, 10
	Knurled plastic	9112, 10
Measurement wheels with circumference of 200 mm	Plastic	9108, 10
	Pimpled rubber	9109, 10
	Knurled aluminium	9110, 10
	Knurled plastic	9113, 10
Mounting aids	Mounting bracket	9203
	Mounting bracket	9213
Connectors	Cable socket	9416
	Cable socket	9416L

For additional information on the accessories, please see the "Accessories" section.

Release date: 2012-01-27 14:56 Date of issue: 2012-01-27 515017\_eng.xml

Order code

**A V S 5 8 N - 0 1 1 Y Y R Y G N - 0 0 1 4**

