



**Model Number**

**BB10-P-F1/33/35/59/102/115-7m**

Thru-beam sensor  
with fixed cable

**Features**

- Single-beam miniature photoelectric sensor, ideal for installing in frames or contours
- Integrated circuit
- Plug-in style housing for 13 mm hole
- Narrow opening angle, suitable for mounting in pairs
- Various frequencies for avoiding mutual interference (cross-talk immunity)
- Dark on version

**Product information**

There is no simpler way of installing a sensor: drill the hole, clip in the sensor and you're done. What's more, the BB10 plug-in sensors for doors and turnstiles offer top performance at an extremely attractive price. The switching mechanism is integrated in the compact, self-contained and temperature-stable housing, making the BB10 suitable even for extremely cold regions with temperatures as low as -40°C.

Release date: 2014-10-30 07:55 Date of issue: 2014-10-30 809334\_eng.xml

**Dimensions**

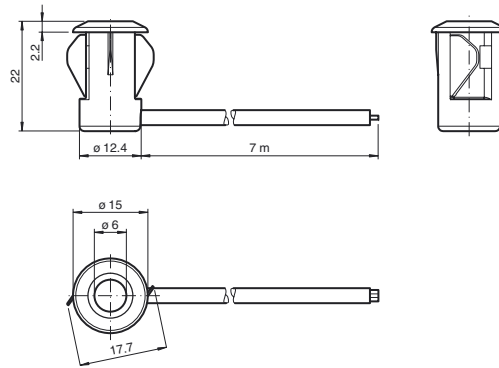

**Electrical connection**

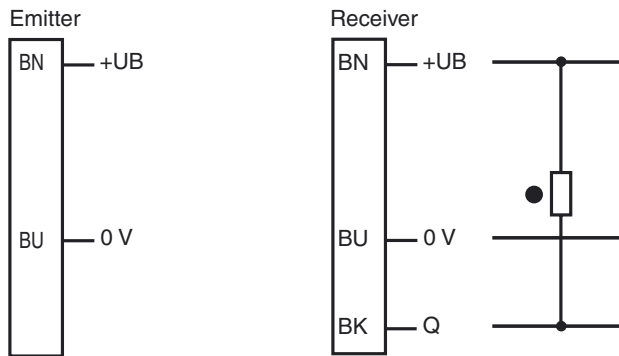

- = Light on
- = Dark on

**Indicators/operating means**

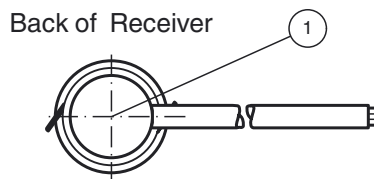

|   |                |     |
|---|----------------|-----|
| 1 | Signal display | red |
|---|----------------|-----|

**Technical data****System components**

|          |                               |
|----------|-------------------------------|
| Emitter  | BB10-T-F1/33/35/115-7m        |
| Receiver | BB10-R-F1/33/35/59/102/115-7m |

**General specifications**

|                            |   |
|----------------------------|---|
| Effective detection range  | 0 ... 3 m   |
| Threshold detection range  | 4 m   |
| Light source               | IREL  |
| Light type                 | modulated infrared light , 880 nm                         |
| Diameter of the light spot | approx. 250 mm at a distance of 1 m                       |
| Angle of divergence        | Emitter: +/- 3 ° Receiver: +/- 10 °                       |
| Optical face               | frontal   |
| Ambient light limit        | halogen light 100000 Lux ; according to EN 60947-5-2:2007 |

**Functional safety related parameters**

|                                |       |
|--------------------------------|-------|
| MTTF <sub>d</sub>              | 795 a |
| Mission Time (T <sub>M</sub> ) | 20 a  |
| Diagnostic Coverage (DC)       | 0 %   |

**Indicators/operating means**

|                    |  |
|--------------------|--|
| Function indicator | LED red: lights up when receiving the light beam ; flashes when falling short of the stability control; OFF when light beam is interrupted |
|--------------------|--|

**Electrical specifications**

|                        |                |                                       |
|------------------------|----------------|---------------------------------------|
| Operating voltage      | U <sub>B</sub> | 10 ... 30 V DC                        |
| No-load supply current | I <sub>0</sub> | Emitter: ≤ 20 mA<br>Receiver: ≤ 10 mA |

**Output**

|                     |   |            |
|---------------------|---|------------|
| Switching type      | dark on   |            |
| Signal output       | 1 NPN output, short-circuit protected, reverse polarity protected, open collector |            |
| Switching voltage   | max. 30 V DC  |            |
| Switching current   | max. 100 mA   |            |
| Voltage drop        | U <sub>d</sub>  | ≤ 1.5 V DC |
| Switching frequency | f   | 100 Hz     |
| Response time       |   | 5 ms       |

**Ambient conditions**

|                     |   |
|---------------------|---|
| Ambient temperature | -40 ... 60 °C (-40 ... 140 °F) , fixed<br>-20 ... 60 °C (-4 ... 140 °F) , movable |
| Storage temperature | -40 ... 70 °C (-40 ... 158 °F)  |
| Relative humidity   | 90 % , noncondensing  |

**Mechanical specifications**

|                      |  |
|----------------------|--|
| Degree of protection | IP67   |
| Connection           | 7 m fixed cable<br>Receiver: grey ; Emitter: black |
| Material             |  |
| Housing              | PC , black   |
| Optical face         | Plastic pane                                       |
| Mass                 | approx. 100 g per device                           |

**Compliance with standards and directives**

|                           |   |
|---------------------------|---|
| Directive conformity      |   |
| EMC Directive 2004/108/EC | EN 60947-5-2:2007                       |
| Standard conformity       |   |
| Product standard          | EN 60947-5-2:2007<br>IEC 60947-5-2:2007 |

**Approvals and certificates**

|                               |  |
|-------------------------------|--|
| CCC approval                  | CCC approval / marking not required for products rated ≤36 V |
| UN/ECE Regulation No. 10 (E1) | Type-approval number: 036938                                 |

**Typical applications**

- Monitoring function for turnstiles
- Activation function for restarting escalators
- Monitoring of industrial gates
- Person detection for automatic doors and gates

**Detection area**

**Curves/Diagrams**

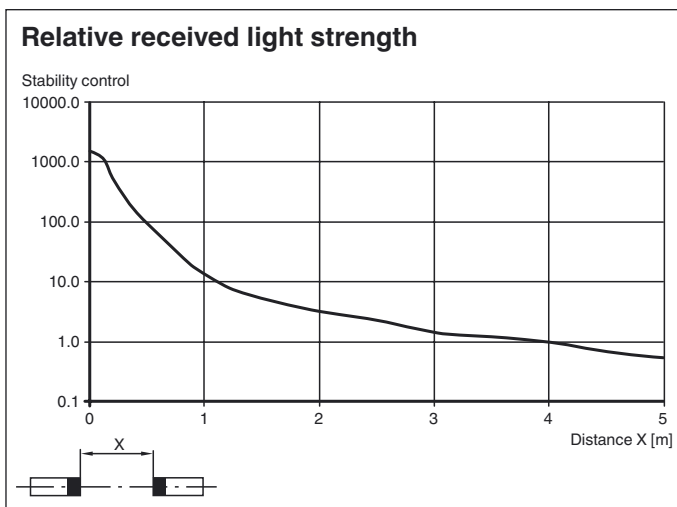
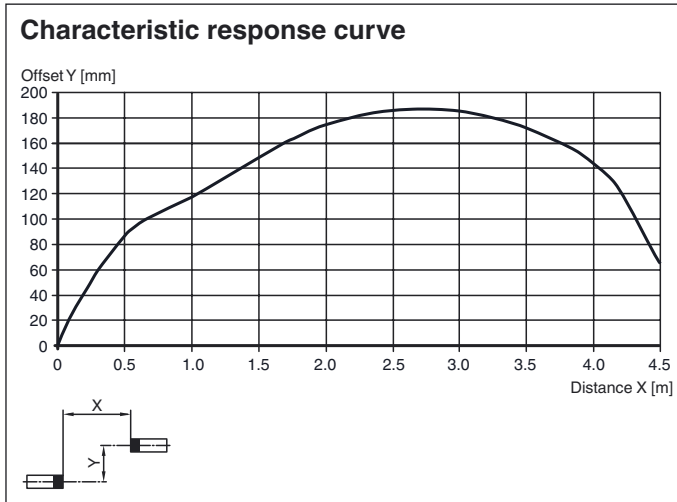

**Operating principle**

The thru-beam sensor requires two devices for operation; a light source and a light receiver. The light source and receiver must be optically aligned with one another in a single line. The infrared light emitted from the source is recorded by the receiver and evaluated. The sensor detects both people and objects for as long as an object interrupts the detection beam, regardless of movement and surface structure.

**Function**

**Static detection:**

The sensor detects both people and objects for as long as an object interrupts the detection beam, regardless of movement and surface structure.

|              |                               | Electronic output |
|--------------|-------------------------------|-------------------|
| Light ON /25 | Person located within beam    | Inactive          |
|              | No people located within beam | Active            |
| Dark ON /59  | Person located within beam    | Active            |
|              | No people located within beam | Inactive          |

**Optics:**

The relatively wide opening angles allow the sensors to be mounted quickly without any alignment issues. Function is maintained even if mounting profiles are slightly distorted.

**Mounting:**

Thanks to its compact dimensions, the sensor fits in U profiles or behind any covers.

Release date: 2014-10-30 07:55 Date of issue: 2014-10-30 809334\_eng.xml

| Sheet thickness [mm] | Hole diameter [mm] |    |
|----------------------|--------------------|----|
|                      |                    | 13 |
| 1                    | OK                 | X  |
| 2                    | OK                 | OK |
| 3                    | OK                 | OK |

X = mounting not possible  
 OK = mounting possible

**Mounting for dual-beam protection:**

For dual-beam versions, two light sources and receivers are required.  
 When using thru-beam sensors with two different transmission frequencies (F1 and F2), it is not necessary to observe a minimum beam distance between the thru-beam sensors.  
 When using thru-beam sensors with the same transmission frequency:  
 Ensure that the minimum beam distance is 20 cm and that the transmitter and receiver are arranged in a cross formation.

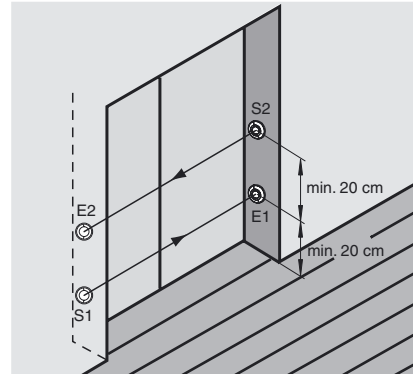

Release date: 2014-10-30 07:55 Date of issue: 2014-10-30 809334\_eng.xml