



**Model Number**

**BB10-P/25/33/76b/103/115e**

Thru-beam sensor  
with fixed cable

**Features**

- Single-beam miniature photoelectric sensor, ideal for installing in frames or contours
- Integrated circuit
- Plug-in style housing for 13 mm hole
- Narrow opening angle, suitable for mounting in pairs
- Light on version
- Version with test input

**Product information**

There is no simpler way of installing a sensor: drill the hole, clip in the sensor and you're done. What's more, the BB10 plug-in sensors for doors and turnstiles offer top performance at an extremely attractive price. The switching mechanism is integrated in the compact, self-contained and temperature-stable housing, making the BB10 suitable even for extremely cold regions with temperatures as low as -40°C.

Release date: 2014-06-23 14:03 Date of issue: 2014-06-23 811260\_eng.xml

**Dimensions**

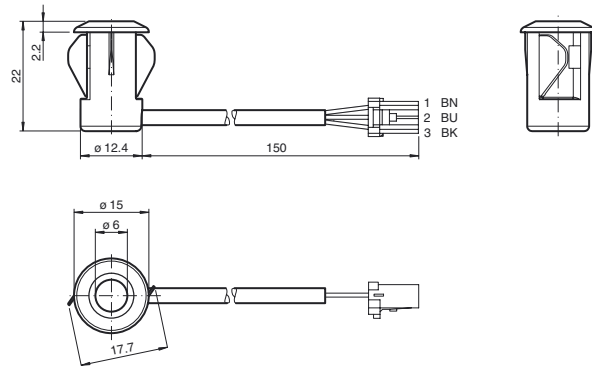

**Electrical connection**

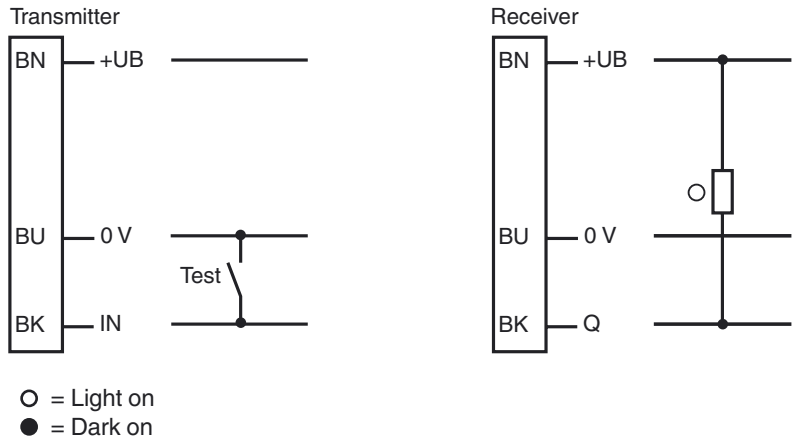

**Indicators/operating means**

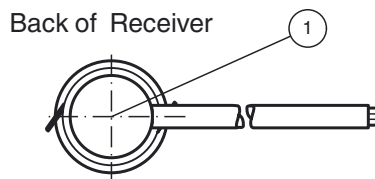

1	Signal display	red
---	----------------	-----

**Technical data****System components**

Emitter	BB10-T/33/76b/115e
Receiver	BB10-R/25/33/103/115e

**General specifications**

Effective detection range	0 ... 6 m
Threshold detection range	8 m
Light source	IREL
Light type	modulated infrared light , 880 nm
Diameter of the light spot	approx. 1300 mm at a distance of 6 m
Angle of divergence	Emitter: +/- 8 ° Receiver: +/- 10 °
Optical face	frontal
Ambient light limit	halogen light 100000 Lux ; according to EN 60947-5-2:2007
Accessories provided	7 m PVC cable with 3-pin JST connector

**Functional safety related parameters**

MTTF <sub>d</sub>	795 a
Mission Time (T <sub>M</sub> )	20 a
Diagnostic Coverage (DC)	0 %

**Indicators/operating means**

Function indicator	LED red: lights up when receiving the light beam ; flashes when falling short of the stability control; OFF when light beam is interrupted
--------------------	--

**Electrical specifications**

Operating voltage	U <sub>B</sub>	10 ... 30 V DC
No-load supply current	I <sub>0</sub>	Emitter: ≤ 20 mA Receiver: ≤ 10 mA

**Input**

Test input	emitter deactivation at 0 V
------------	-----------------------------

**Output**

Switching type	light on	
Signal output	1 PNP output, short-circuit protected, reverse polarity protected, open collector	
Switching voltage	max. 30 V DC	
Switching current	max. 100 mA	
Voltage drop	U <sub>d</sub>	≤ 1.5 V DC
Switching frequency	f	62.5 Hz
Response time	8 ms	

**Ambient conditions**

Ambient temperature	-40 ... 60 °C (-40 ... 140 °F) , fixed -20 ... 60 °C (-4 ... 140 °F) , movable
Storage temperature	-40 ... 70 °C (-40 ... 158 °F)
Relative humidity	90 % , noncondensing

**Mechanical specifications**

Degree of protection	IP67
Connection	0.15 m cable with 3-pin JST connector Receiver: grey ; Emitter: black
Material	
Housing	PC , black
Optical face	Plastic pane
Mass	approx. 25 g per device

**Compliance with standards and directives**

Directive conformity	
EMC Directive 2004/108/EC	EN 60947-5-2:2007
Standard conformity	
Product standard	EN 60947-5-2:2007 IEC 60947-5-2:2007

**Approvals and certificates**

CCC approval	CCC approval / marking not required for products rated ≤36 V
UN/ECE Regulation No. 10 (E1)	Type-approval number: 036938

**Typical applications**

- Monitoring function for turnstiles
- Activation function for restarting escalators
- Monitoring of industrial gates
- Person detection for automatic doors and gates

**Detection area**

**Curves/Diagrams**

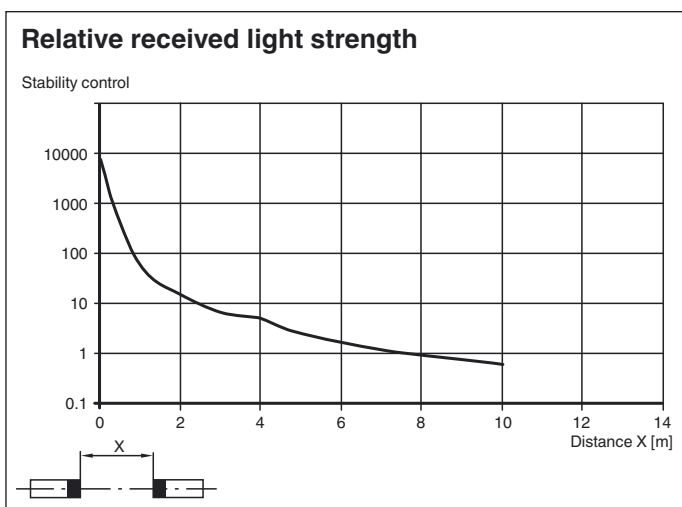
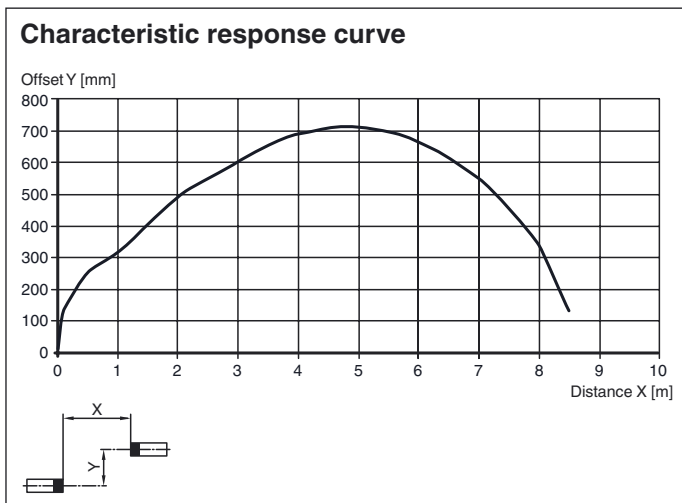

**Operating principle**

The thru-beam sensor requires two devices for operation; a light source and a light receiver. The light source and receiver must be optically aligned with one another in a single line. The infrared light emitted from the source is recorded by the receiver and evaluated. The sensor detects both people and objects for as long as an object interrupts the detection beam, regardless of movement and surface structure.

**Function**

The Series BB10 thru-beam sensor requires a pair of devices for operation, comprising a light transmitter and a light receiver. The transmitter and receiver must be arranged in optical alignment with each other. The infrared light from the transmitter is detected by the receiver and evaluated.

**Static detection:**

The thru-beam sensor detects persons and objects independently of movement and surface structure for as long as the object breaks the detection beam.

		Electronic output
Light detection /25	Person in the beam	Inactive
	No person in the beam	Active
Dark detection /59	Person in the beam	Active
	No person in the beam	Inactive

**Installation:**

Thanks to its small dimensions, the light beam can be fitted in a U-profile or behind a face panel.

Sheet thickness [mm]	Hole diameter [mm]	
		13
1	OK	X
2	OK	OK
3	OK	OK

X = Mounting not possible

Release date: 2014-06-23 14:03 Date of issue: 2014-06-23 811260\_eng.xml

Refer to "General Notes Relating to Pepperl+Fuchs Product Information".

OK = Mounting possible

**Installation of twin-beam arrangement:**

A twin-beam version requires 2 transmitters and receivers.

When using thru-beam sensors with the same transmission frequency:

Ensure that the minimum beam distance is 20 cm and that the light source and receiver are arranged in a cross formation.

