

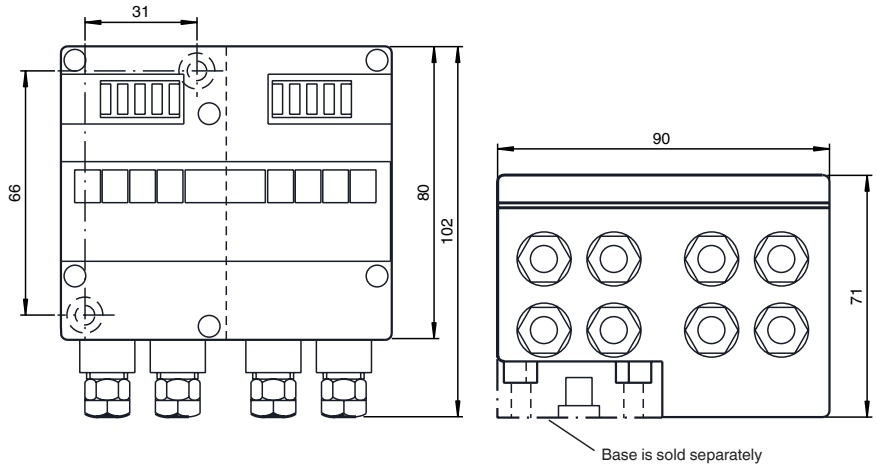

**Dimensions**

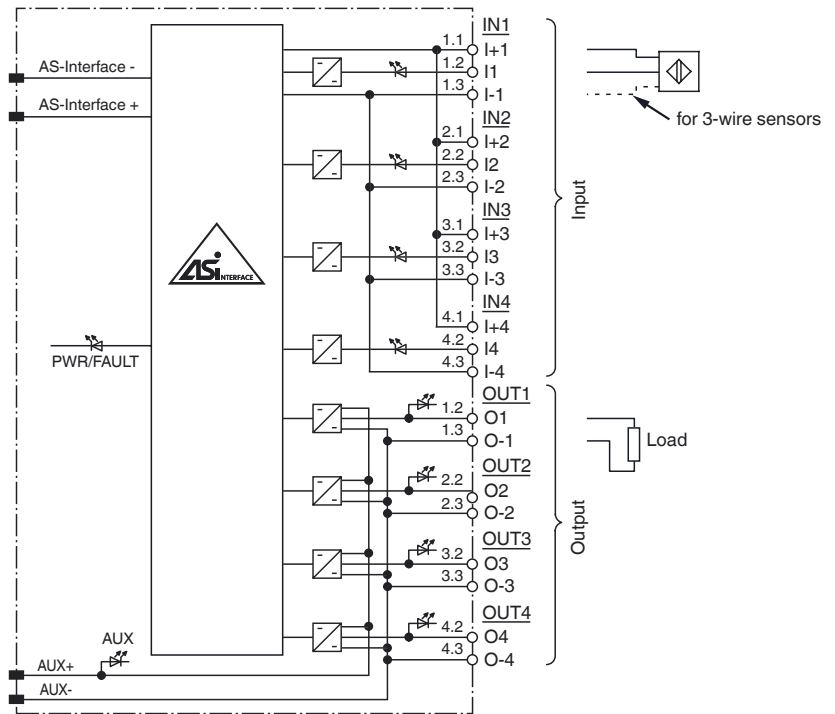

**Electrical connection**



**Model number**

**VAA-4E4A-G4-ZE/E2-Y909711**

G4 module IP65  
4 inputs (PNP) and 4 electronic outputs

**Features**

- Protection degree IP65
- Flat or round cable connection (via standardized EEMS base, not included with delivery)
- Cable piercing method for flat cable
- Communication monitoring, turn-off
- Inputs for 2- and 3-wire sensors
- Power supply of outputs from the external auxiliary voltage
- Power supply of inputs from the module
- Function display for bus, ext. auxiliary voltage, inputs and outputs
- Monitoring of sensor overloads
- Hot glue added for additional circuit board stability in high vibration applications

**Indicating / Operating means**

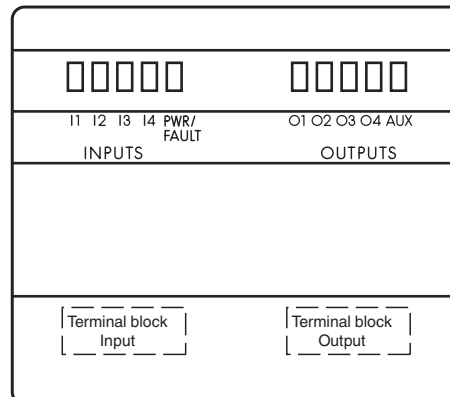

Release date: 2010-04-27 22:41 Date of issue: 2014-01-13 909711\_eng.xml

**Technical data****General specifications**

Slave type	Standard slave
AS-Interface specification	V3.0
Required master specification	≥ V2.0
UL File Number	E87056

**Indicators/operating means**

LED PWR/FAULT	dual LED green/red green: AS-Interface voltage red: communication error or address 0 green/red flashing: overload sensor supply or outputs
LED AUX	ext. auxiliary voltage $U_{AUX}$ ; LED green
LED IN	switching state (input); 4 LED yellow
LED OUT	Switching state (output); 4 LED yellow

**Electrical specifications**

Auxiliary voltage (output)	$U_{AUX}$	24 V DC ± 15 % PELV
Rated operating voltage	$U_e$	26.5 ... 31.6 V from AS-Interface
Rated operating current	$I_e$	≤ 30 mA (without sensors) / max. 230 mA
Protection class		III

**Input**

Number/Type	4 inputs for 2- or 3-wire sensors (PNP), DC
Supply	from AS-Interface
Voltage	21 ... 31 V
Current loading capacity	≤ 200 mA ( $T_B \leq 40 \text{ }^\circ\text{C}$ ), ≤ 160 mA ( $T_B \leq 60 \text{ }^\circ\text{C}$ ), short-circuit protected
Input current	≤ 9 mA (limited internally)
Switching point	according to DIN EN 61131-2 (Type 2)
0 (unattenuated)	≤ 3 mA
1 (attenuated)	≥ 5 mA

**Output**

Number/Type	4 electronic outputs, PNP, overload and short-circuit proof
Supply	from external auxiliary voltage $U_{AUX}$
Current	1 A per output, 4 A total
Voltage	≥ ( $U_{AUX} - 0.5 \text{ V}$ )

**Programming instructions**

Profile	S-7.0
IO code	7
ID code	0
ID1 code	F
ID2 code	E

Data bits (function via AS-Interface)	input	output
D0	IN1	OUT1
D1	IN2	OUT2
D2	IN3	OUT3
D3	IN4	OUT4

**Parameter bits (programmable via AS-i) function**

P0	communication monitoring P0 = 1 (basic setting), monitoring = ON, i.e. if communication fails, the outputs are de-energised P0 = 0, monitoring = OFF, if communication fails, the outputs maintain their condition
P1	not used
P2	not used
P3	not used

**Ambient conditions**

Ambient temperature	-25 ... 60 °C (-13 ... 140 °F)
Storage temperature	-25 ... 85 °C (-13 ... 185 °F)

**Mechanical specifications**

Protection degree	IP65
Connection	cable piercing method or terminal compartment yellow flat cable/black flat cable or standard round cable inputs/outputs: M12 x 1.5 cable glands and cage tension spring terminals
Material	
Housing	PA 6 GF30
Mass	350 g
Mounting	DIN rail or screw mounting

**Compliance with standards and directives**

Directive conformity	
EMC Directive 2004/108/EC	EN 61000-6-2:2001, EN 61000-6-4:2001, EN 50295:1999
Standard conformity	
Noise immunity	EN 61000-6-2:2001
Emitted interference	EN 61000-6-4:2001
Input	EN 61131-2:2007
Protection degree	EN 60529:2000
Fieldbus standard	EN 50295:1999, IEC 62026-2:2006

**Function**

The AS-Interface Module VAA-4E4A-G4-ZE/E2 has 4 inputs and 4 outputs. Both 2-wire and 3-wire sensors and also mechanical contacts can be connected to the inputs. The sensors are supplied from the module. The outputs are electronic, which can be loaded to a max. 24 V DC and 1 A per output.

the G4 Module is particularly suitable for harsh field conditions. The connections to the sensors/actuators are made via cable glands and cage spring terminals. This makes the installation particularly user-friendly. Pre-addressing can be carried out by plugging the module directly into the VBP-HH1 hand-held programming device adapter.

An LED is provided for each channel on the top of the module to indicate the current switching status. Communication monitoring is integrated in the module. In the event of faults on the bus the monitoring system switches off the current to the outputs.

Connection the AS-Interface transfer cable and the external 24 V DC supply can be achieved by means of flat or round cable. If the AS-Interface flat cable is used, the U-G1FF base component is required. The contact with the two cables is made via the AS-Interface-standardised EEMS interface, i. e. by means of the insulation penetration technique.

If a round cable is used, the U-G1PP base component is required. This base also provides the option of connecting both the AS-Interface cable and the external power supply.

**Note:**

The device features communication monitoring. When this is active, it switches off the power to the outputs when no communication has occurred on the AS-Interface cable for more than 40 ms.

In the event of overloading of the internal input power supply or output supply, a signal is communicated to the AS-Interface master via the "Peripheral error" function. Communication via the AS-Interface remains uninterrupted.

**Accessories****VAZ-G4-B1**

Blind plug M12

**Matching system components****U-G1FF**

AS-Interface module mounting base for connection to flat cable (AS-Interface and external auxiliary power)

**U-G1FFA**

AS-Interface module mounting base with addressing jack for connection to flat cable (AS-Interface and external auxiliary power)

**U-G1PP**

AS-Interface module mounting base for connection to round cable (AS-Interface and external auxiliary power)

**Notes**

Do not connect inputs and outputs, which are supplied via the module from AS-interface or via auxiliary power, with power supply and signal circuits with external potentials.