

Model Number

AVM78E

Features

- Up to 30 Bit multiturn
- ATEX approval
- IECEx approval
- Flameproof enclosure
- Removable connection cap
- Galvanically isolated RS 422 interface

Description

This absolute rotary encoder returns a position value corresponding to the shaft position via the SSI interface.

In order to obtain the position data, the controller sends a start sequence to the absolute rotary encoder. The encoder then responds synchronously to the pulses from the controller with the position data. The modular design enables you to order the absolute rotary encoder so that it fulfills your requirements. A listing of the part options can be found in the ordering information.

You can select the counting direction via 2 functional inputs and set the zero position.

Technical data

General specifications

Detection type	photoelectric sampling
Device type	Multiturn absolute encoder

Functional safety related parameters

MTTF _d	30 a
Mission Time (T _M)	20 a
L _{10h}	7.7 E+9 at 3000 rpm
Diagnostic Coverage (DC)	0 %

Electrical specifications

Operating voltage U _B	10 ... 30 V DC
No-load supply current I ₀	max. 90 mA
Linearity	± 2 LSB at 16 Bit, ± 1 LSB at 13 Bit, ± 0,5 LSB at 12 Bit
Output code	Gray code, binary code
Code course (counting direction)	see input 1

Interface

Interface type	SSI
Monoflop time	20 ± 10 μs

Resolution

Single turn	up to 16 Bit
Multiturn	up to 14 Bit
Overall resolution	up to 30 Bit
Transfer rate	0.1 ... 2 MBit/s
Standard conformity	RS 422

Input 1

Input type	Selection of counting direction (cw/ccw)
Signal voltage	
High	10 ... 30 V or open input cw descending (clockwise rotation, code course descending)
Low	0 ... 2 V cw ascending (clockwise rotation, code course ascending)
Input current	< 6 mA
Switch-on delay	< 10 ms

Input 2

Input type	zero-set (PRESET)
Signal voltage	
High	10 ... 30 V
Low	0 ... 2 V
Input current	< 6 mA
Signal duration	≥ 100 ms
Switch-on delay	< 10 ms

Connection

Cable	Ø 10.2 mm, Radox 9 x 0.5 mm ²
Terminal compartment	see ordering information

Standard conformity

Degree of protection	DIN EN 60529, IP66
Climatic testing	DIN EN 60068-2-3, no moisture condensation
Emitted interference	EN 61000-6-4:2007
Noise immunity	EN 61000-6-2:2005
Shock resistance	DIN EN 60068-2-27, 100 g, 3 ms
Vibration resistance	DIN EN 60068-2-6, 10 g, 10 ... 2000 Hz

Ambient conditions

Operating temperature	-40 ... 70 °C (-40 ... 158 °F)
Storage temperature	-40 ... 85 °C (-40 ... 185 °F)

Mechanical specifications

Material	
Combination 1	housing: anodized aluminum flange: aluminum, blank shaft: Stainless steel 1.4401 / AISI 316
Combination 2 (Inox)	housing: Stainless steel 1.4404 / AISI 316L flange: Stainless steel 1.4404 / AISI 316L shaft: Stainless steel 1.4401 / AISI 316
Mass	approx. 2600 g (combination 1) approx. 3900 g (combination 2)
Rotational speed	max. 3000 min ⁻¹
Moment of inertia	180 gcm ²
Starting torque	≤ 4 Ncm
Shaft load	
Axial	60 N
Radial	80 N

Data for application in connection with

Ex-areas	
EC-Type Examination Certificate	TÜV 11 ATEX 084272X IECEX TUN 11.0017X
Group, category, type of protection	(Ex) II 2G Ex d IIC T5 Gb (Ex) II 2D Ex tb IIIC T100°C Db IP6X
Directive conformity	
Directive 94/9/EC	IEC 60079-0:2007 EN 60079-0:2009 IEC 60079-1:2007 EN 60079-1:2007 IEC 60079-31:2008 EN 60079-31:2009

Dimensions

Encoder length L

Version		Length L
Radial cable exit	Clamping flange	118 mm
	Servo flange	118 mm
Axial cable exit	Clamping flange	134 mm
	Servo flange	134 mm

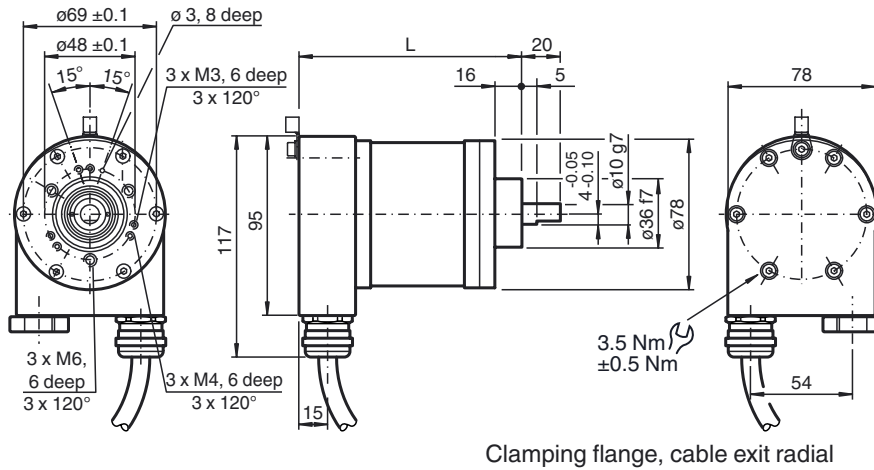

Clamping flange, cable exit radial

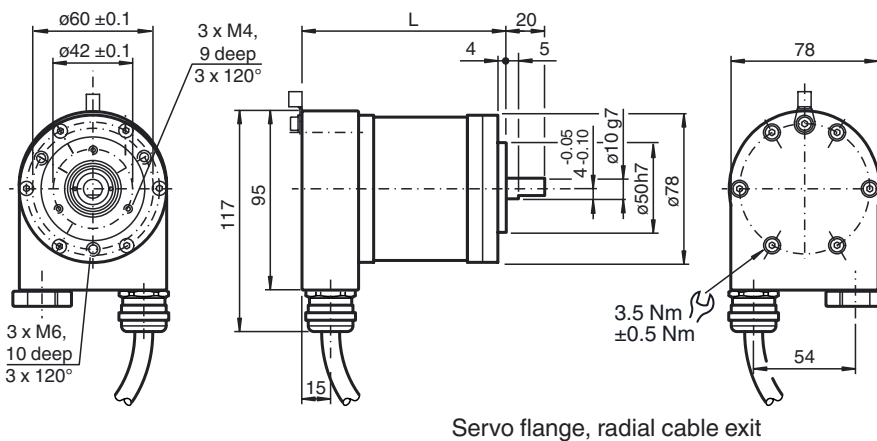

Servo flange, radial cable exit

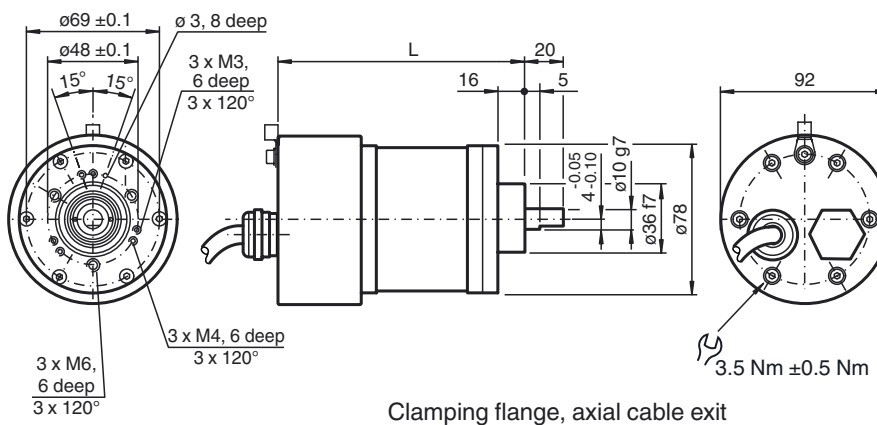

Clamping flange, axial cable exit

Release date: 2014-04-15 10:07 Date of issue: 2014-04-15 1157829_eng.xml

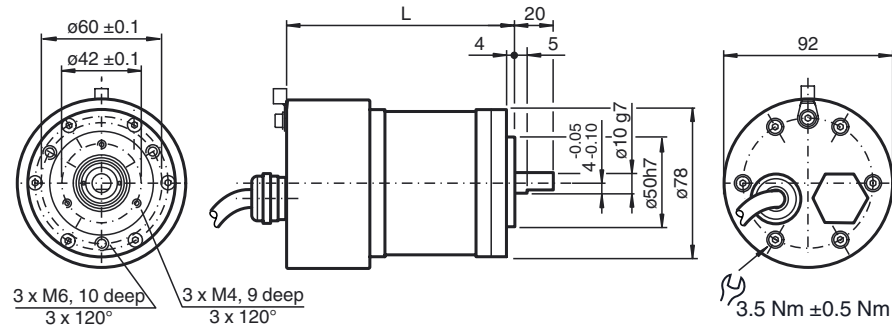

Servo flange, axial cable exit

Shaft 12 mm

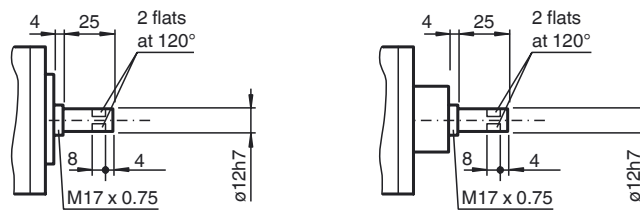

Electrical connection

Signal	Cable	Terminal compartment
Ground wire	green-yellow	Grounding terminal
GND (rotary encoder)	1	1
+U _b (rotary encoder)	2	2
Pulse (+)	3	5
Pulse (-)	4	6
Data (+)	5	8
Data (-)	6	7
Preset	7	4
Counting direction	8	3

Release date: 2014-04-15 10:07 Date of issue: 2014-04-15 t157829_eng.xml

Description

The Synchronous Serial Interface was specially developed for transferring the output data of an absolute encoder to a control device. The control module sends a clock bundle and the absolute encoder responds with the position value.

Thus only 4 lines are required for the clock and data, no matter what the resolution of the rotary encoder is. The RS 422 interface is optically isolated from the power supply.

SSI signal course Standard

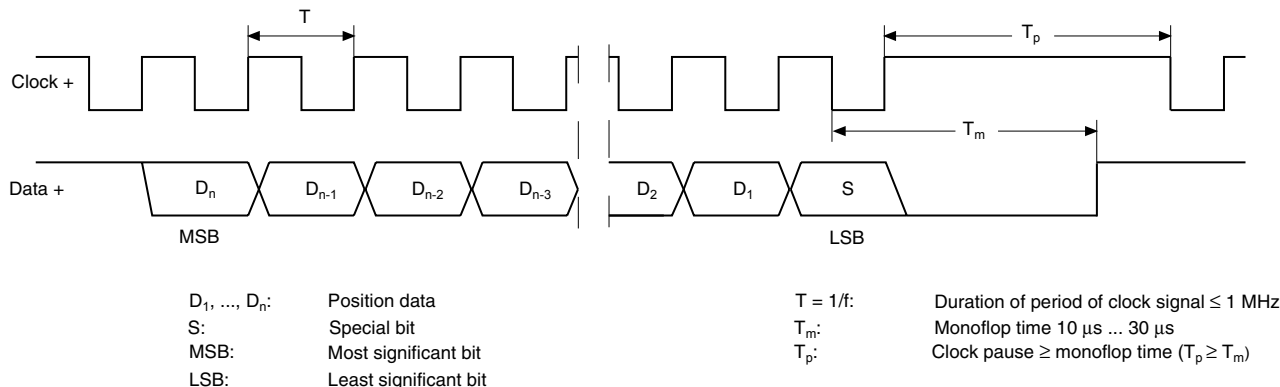

SSI output format Standard

- At idle status signal lines "Data +" and "Clock +" are at high level (5 V).
- The first time the clock signal switches from high to low, the data transfer in which the current information (position data (D_n) and special bit (S)) is stored in the encoder is introduced.
- The highest order bit (MSB) is applied to the serial data output of the encoder with the first rising pulse edge.
- The next successive lower order bit is transferred with each following rising pulse edge.
- After the lowest order bit (LSB) has been transferred the data line switches to low until the monoflop time T_m has expired.
- No subsequent data transfer can be started until the data line switches to high again or the time for the clock pause T_p has expired.
- After the clock sequence is complete, the monoflop time T_m is triggered with the last falling pulse edge.
- The monoflop time T_m determines the lowest transmission frequency.

SSI output format ring slide operation (multiple transmission)

- In ring slide operation, multiple transmission of the same data word over the SSI interface makes it possible to offer the possibility of detecting transmission errors.
- In multiple transmission, 25 bits are transferred per data word in standard format.
- If the clock change is not interrupted after the last falling pulse edge, ring slide operation automatically becomes active. This means that the information that was stored at the time of the first clock change is generated again.
- After the first transmission, the 26th pulse controls data repetition. If the 26th pulse follows after an amount of time greater than the monoflop time T_m , a new current data word will be transmitted with the following pulses.



If the pulse line is exchanged, the data word is generated offset. Ring slide operation is possible up to max. 13 bits.

Block diagram

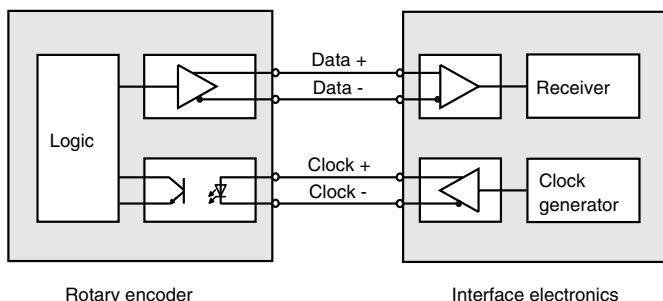

Line length

Line length in m	Baudrate in kHz
< 50	< 400
< 100	< 300
< 200	< 200
< 400	< 100

Inputs

The selection of the counting direction input (cw/ccw) is activated with 0-level. The zero-set input (PRESET 1) is activated with 1-level.

zero-set input (PRESET 1)

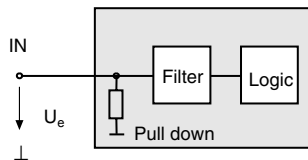

Input for selection of counting direction (cw/ccw)

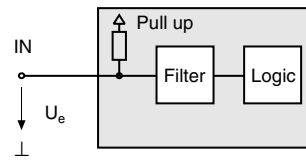

Ordering information

A	V	M	7	8	E	-	0													
											Number of singleturn bits		12 4096		16 65536					
											Number of multiturn bits		12 4096		14 16384					
											Housing material									
											N Aluminum									
											I Stainless steel 1.4404 (AISI 316L)									
											Output code									
											B Binary									
											G Gray									
											Option 2									
											0 Zeroing (preset) and counting direction (F/R)									
											Exit position									
											A axial									
											R radial									
											Connection type									
											K2 Cable, 9 strands, 2 m									
											K5 Cable, 9 strands, 5 m									
											KR Terminal compartment, 1 cable gland, 1 stopping plug									
											Flange version									
											1 Clamping flange									
											2 Servo flange									
											Shaft dimension									
											01 Shaft Ø10 mm x 20 mm									
											02 Shaft Ø12 mm x 25 mm									
											Option 1									
											E Explosion-proof, standard IP66									
											Functional principle									
											M Multiturn									
											Type of shaft									
											V Solid shaft									
											Data format									
											A SSI interface									

Release date: 2014-04-15 10:07 Date of issue: 2014-04-15 t157829_eng.xml