

Model Number

EVS58-PZ

Features

- Industrial standard housing Ø58 mm
- Ethernet interface with Powerlink
- 16 Bit singleturn
- Two Ethernet connectors with built in hub
- Servo or clamping flange

Description

Absolute rotary encoders deliver an absolute step value for each angle setting.

On account of the high number of measuring steps, this type of absolute rotary encoder can be used to divide very long linear distances into small measuring steps.

The Ethernet interface of this absolute encoder supports the Powerlink V2 protocol. An integrated hub allows wiring in a line structure (daisy chain). In addition to various functions like resolution adjustment, rotation direction, node number setting or limit switch adjustment, the following operation modes can be selected:

- Polled mode
- Multiplexed mode
- Poll response chaining

The device is designed for shaft assembly and is available in servo flange or clamping flange design.

Technical data

General specifications

Detection type	photoelectric sampling
Device type	Singleturn absolute encoder

Functional safety related parameters

MTTF _d	130 a
Mission Time (T _M)	20 a
L _{10h}	1.9 E+11 at 6000 rpm and 20/40 N axial/radial shaft load
Diagnostic Coverage (DC)	0 %

Electrical specifications

Operating voltage U _B	10 ... 30 V DC , safe galvanic isolation per EN 50178
Power consumption P ₀	max. 3 W
Linearity	± 0.5 LSB (12 Bit) , ± 2 LSB (16 Bit)
Output code	binary code
Code course (counting direction)	programmable, cw ascending (clockwise rotation, code course ascending) cw descending (clockwise rotation, code course descending)

Interface

Interface type	Ethernet Powerlink
Resolution	
Single turn	up to 16 Bit
Overall resolution	up to 16 Bit
Physical	Ethernet
Transfer rate	100 MBit/s

Connection

Connector	Ethernet: 2 sockets M12 x 1, 4-pin, D-coded Supply: 1 plug M12 x 1, 5-pin, A-coded
-----------	---

Standard conformity

Degree of protection	DIN EN 60529, shaft side: IP64 (without shaft seal)/IP66 (with shaft seal) housing side: IP65
Climatic testing	DIN EN 60068-2-3, no moisture condensation
Emitted interference	EN 61000-6-4:2007
Noise immunity	EN 61000-6-2:2005
Shock resistance	DIN EN 60068-2-27, 100 g, 6 ms
Vibration resistance	DIN EN 60068-2-6, 10 g, 10 ... 2000 Hz

Ambient conditions

Operating temperature	-40 ... 85 °C (-40 ... 185 °F)
Storage temperature	-40 ... 85 °C (-40 ... 185 °F)
Relative humidity	98 % , no moisture condensation

Mechanical specifications

Material	housing: powder coated aluminum flange: aluminum shaft: stainless steel
Mass	approx. 550 g
Rotational speed	max. 12000 min ⁻¹
Moment of inertia	30 gcm ²
Starting torque	≤ 3 Ncm (version without shaft seal)
Shaft load	
Axial	40 N
Radial	80 N

Approvals and certificates

UL approval	cULus Listed, General Purpose, Class 2 Power Source
CCC approval	CCC approval / marking not required for products rated ≤36 V

Dimensions

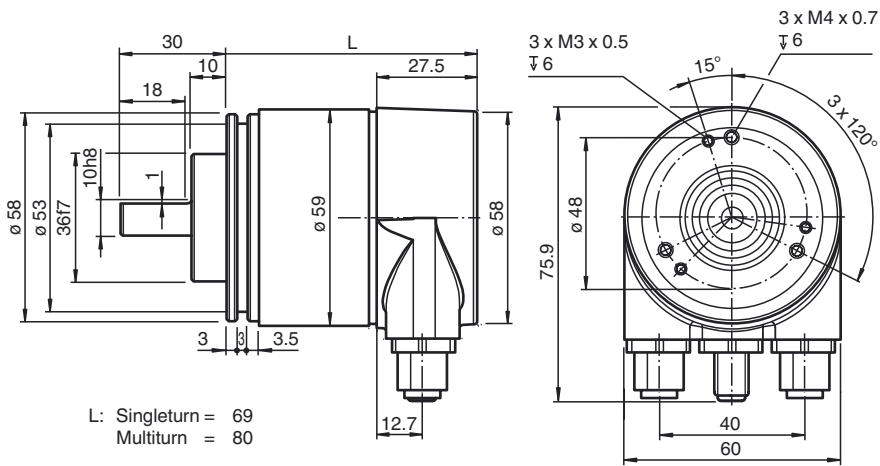
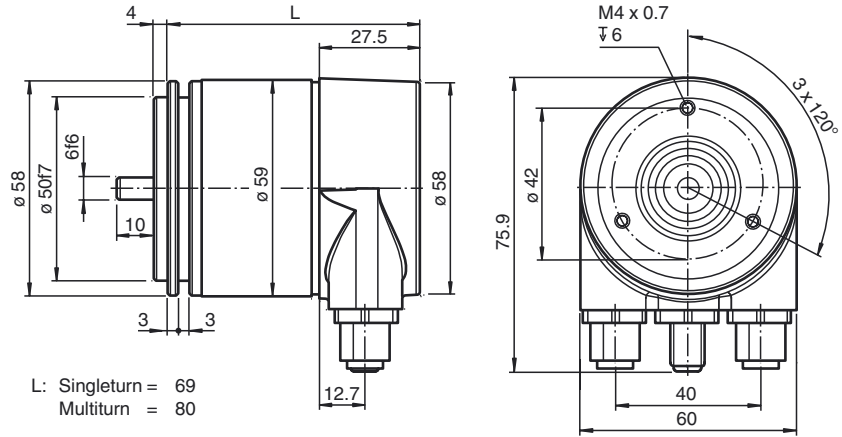

Electrical connection

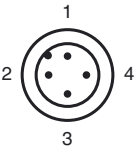
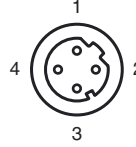
Pin	Male connector M12 x 1, 4-pin, A-coded	Female connector M12 x 1, 4-pin, D-coded
1	Supply voltage +U _B	Tx +
2	-	Rx +
3	0 V	Tx -
4	-	Rx -
		

Release date: 2015-01-29 08:43 Date of issue: 2015-01-29 t163530_eng.xml

Refer to "General Notes Relating to Pepperl+Fuchs Product Information".

Pepperl+Fuchs Group
www.pepperl-fuchs.com

USA: +1 330 486 0001
fa-info@us.pepperl-fuchs.com

Germany: +49 621 776 4411
fa-info@de.pepperl-fuchs.com

Singapore: +65 6779 9091
fa-info@sg.pepperl-fuchs.com

Indicators and operation means

LEDs for HUB Port

LED	Color	Status	Meaning
LS/DA 1	green	on	LINK active for HUB Port 1
		blinking	Activity on HUB Port 1
LS/DA 2	green	on	LINK active for HUB Port 2
		blinking	Activity on HUB Port 2

LEDs for Powerlink

LED	Color	Status	Meaning
Error	red	on	- not allowed node number - internal communication error - buffer underrun/overflow - collision - CRC error - loss of SoC
		off	no error
Status	green	off	not active
		flickering	Basic Ethernet mode
		flashes 1x	Pre-Operational 1
		flashes 2x	Pre-Operational 2
		flashes 3x	ready to operate
		on	Operational
		blinking	Stopped

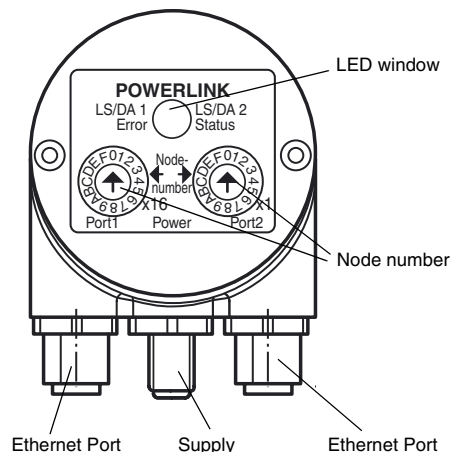

Node number adjustment

The setting of the controlled node number is achieved by 2 hexadecimally switches x16 and x1.

Allowed node numbers range is 1 ... 239. The adjusted node number is calculated as follows:

$$\text{Node number} = \text{Decimal value}_{[\text{switch x16}]} \times 16 + \text{Decimal value}_{[\text{switch x1}]} \times 1$$

Example:

$$[\text{switch x16}] = A, [\text{switch x1}] = 5$$

$$A_{\text{hex}} = 10_{\text{dec}} \times 16 = 160 + 5 = 165$$

Order code



Number of bits singleturn

13	8192 (standard)
16	65536

Temp.
N normal

Output code
B binary

Option
0 none

Exit position
R radial

Connection type / protocol

PZ Powerlink protocol, 2 female connectors/1 male connector, M12 x 1

Flange version

- 1 Clamping flange
- 2 Servo flange

Shaft dimensions

- 01 Shaft Ø10 mm x 20 mm
- 03 Shaft Ø6 mm x 10 mm

Housing material

- N Aluminium, powder coated
- W Aluminium, powder coated with shaft seal

Function principle

- S Singleturn

Shaft version

- V Solid shaft

Data format

- E Ethernet

Release date: 2015-01-29 08:43 Date of issue: 2015-01-29 t163530_eng.xml