

Model Number

JVM36M-*****

Features

- **Very small housing**
- **High climatic resistance**
- **Up to 27 Bit multiturn**
- **CAN bus with SAE J1939 protocol**
- **Surge and reverse polarity protection**

Description

This absolute rotary encoder provides a position value corresponding to the shaft position on its integrated J1939 interface. The rugged miniature encoders are based on magnetic sampling.

Technical data

General specifications

Detection type	magnetic sampling
Device type	Multiturn absolute encoder

Electrical specifications

Operating voltage U_B	10 ... 30 V DC
Power consumption P_0	max. 1.2 W
Output code	binary code
Code course (counting direction)	adjustable

Interface

Interface type	J1939
Resolution	
Single turn	up to 12 Bit (hysteresis: 0.1 °)
Multiturn	up to 15 Bit
Overall resolution	up to 27 Bit
Transfer rate	250 kBit/s
Standard conformity	ISO 11898

Connection

Connector	M12 connector, 5 pin
Cable	Ø6 mm, 4 x 2 x 0.14 mm ² , 1 m

Standard conformity

Degree of protection	acc. DIN EN 60529
Connection side	cable models: IP54 connector models: IP65
Shaft side	IP54
Climatic testing	DIN EN 60068-2-3 , 98 % , no moisture condensation
Emitted interference	EN 61000-6-4:2007
Noise immunity	EN 61000-6-2:2005
Shock resistance	DIN EN 60068-2-27, 100 g, 6 ms
Vibration resistance	DIN EN 60068-2-6, 10 g, 10 ... 1000 Hz

Ambient conditions

Operating temperature	cable, flexing: -5 ... 70 °C (-23 ... 158 °F), cable, fixed: -30 ... 70 °C (-22 ... 158 °F) connector models: -30 ... 85 °C (-22 ... 185 °F)
Storage temperature	cable models: -30 ... 70 °C (-22 ... 158 °F) connector models: -30 ... 85 °C (-22 ... 185 °F)
Relative humidity	98 % , no moisture condensation

Mechanical specifications

Material	
Housing	nickel-plated steel
Flange	aluminum
Shaft	Stainless steel
Mass	approx. 150 g , with cable
Rotational speed	max. 12000 min ⁻¹
Moment of inertia	30 gcm ²
Starting torque	< 3 Ncm
Shaft load	
Axial	20 N
Radial	40 N

Dimensions

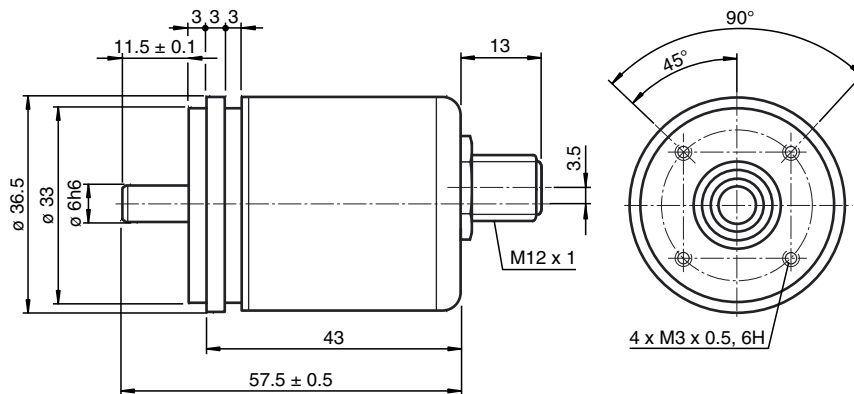
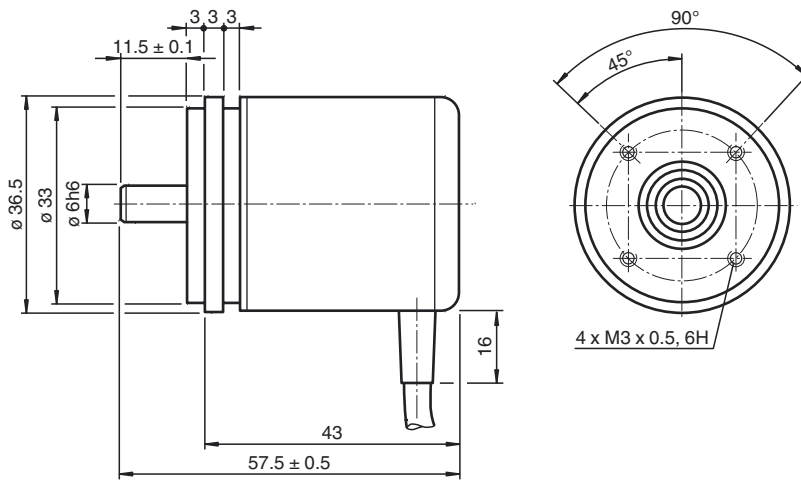
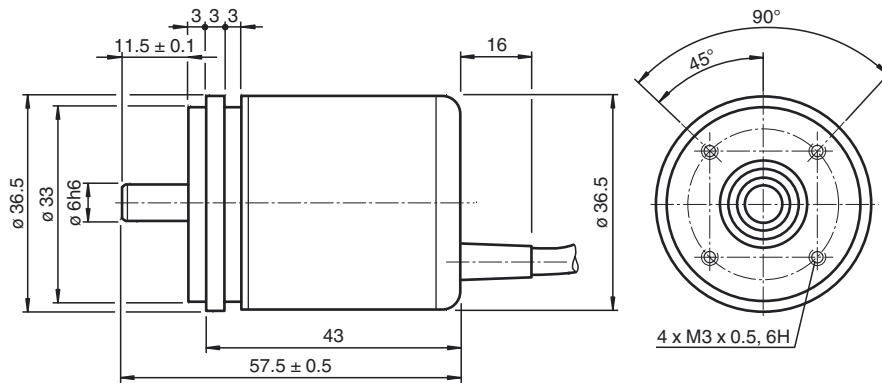

Release date: 2014-11-17 13:01 Date of issue: 2014-11-17 t168184_eng.xml

Electrical connection

Signal	Wire end	5-pin, M12 x 1 connector
CAN GND	green	1
+V _S	red	2
GND	yellow	3
CAN-High	white	4
CAN-Low	brown	5
Shielding	Shielding	Housing
Pinout		

Example of the transmit commands

Command	Identifier	Data	Comments
Read request Direction	18EA2000	01 EF 00 00 00 00 00 00	
Read request Node	18EA2000	08 EF 00 00 00 00 00 00	
Write Direction	00EF2000	01 01 00 00 00 FF FF FF (CCW increase position)	When you change direction it will give you a different positional value. You will then need to set your preset value.
Write PRESET	00EF2000	04 A8 61 00 00 FF FF FF (value 25.000)	The preset value should be received at positional value 18FFAA20.
Write Save	00EF2000	FA 73 61 76 65 FF FF FF	The settings saved in non-volatile memory

If you change the node number, you will need to cycle power (after you save your settings) for the node number to change. Once you cycle power, you will need to enter the new node number in your identifier. You can confirm everything is saved in non-volatile memory by cycling power.

Receive:

18FFAA20: Positional and speed data

18EA2000: Read response

Order code

J V M 3 6 M - 0 3 S 0 B N - 1 2

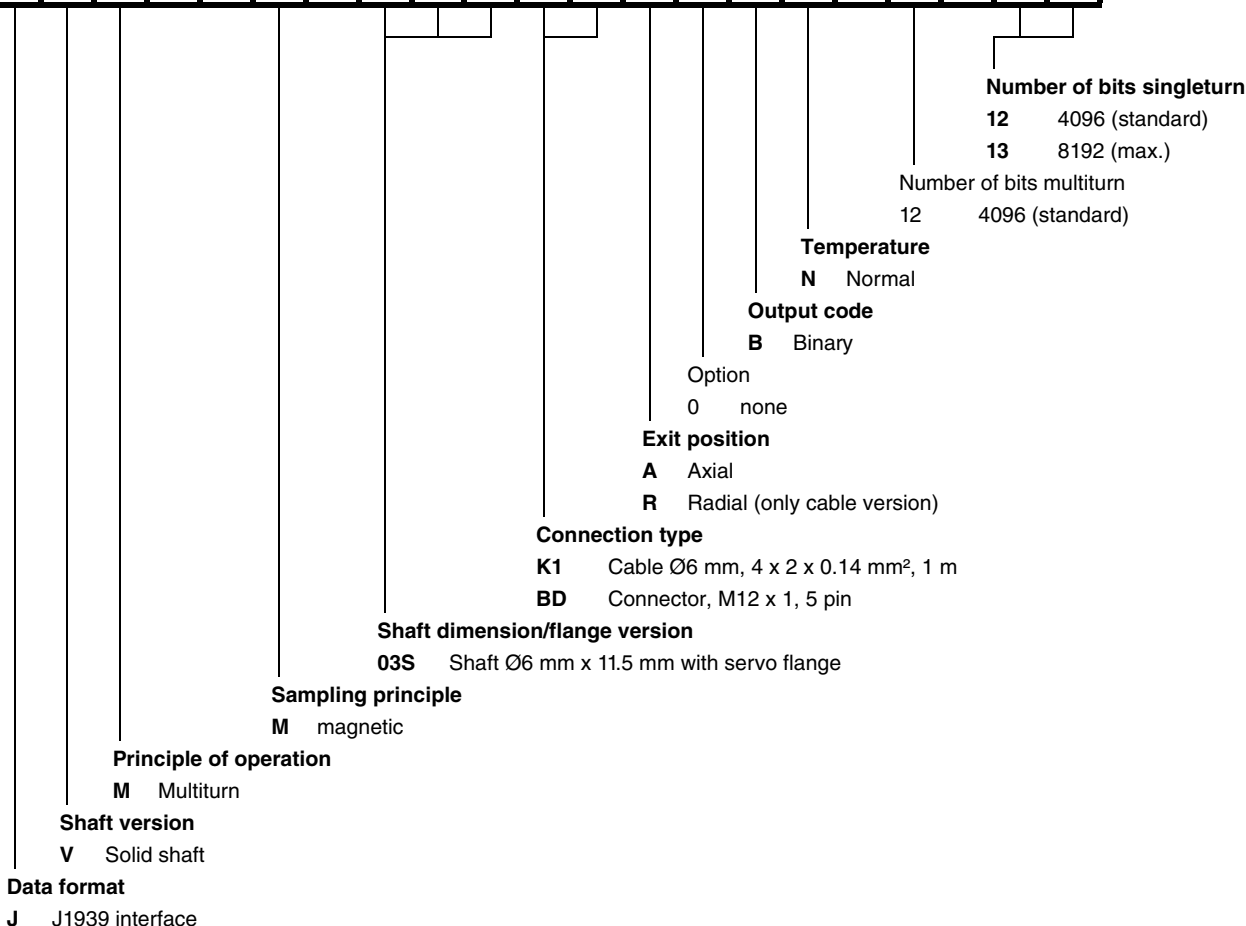

Release date: 2014-11-17 13:01 Date of issue: 2014-11-17 t168184_eng.xml