

### Model Number

TVI50N-09BK0\*\*T

### Features

- **Sturdy and compact design**
- **Up to 1024 ppr**
- **4.75 V ... 30 V with short-circuit proof push-pull output**
- **RS 422 functionality at 5 V operation**

### Description

The TVI50 is the starting point for the new economical target line of Pepperl+Fuchs. With a small outside diameter of 50 mm, the unit is ideal for use in industrial areas where little space is available.

The technology of the rotary encoder is adapted to the new requirements of the rotary encoder market. Innovative fast technology with Opto-ASIC forms the central basis of the device. The rotary encoder is available with a pulse count of up to 1024 pulses per revolution.

The rotary encoder provides the ideal combination of non-sensitivity to temperature and high resolution.

## Technical data

### General specifications

Detection type	photoelectric sampling
Pulse count	max. 1024

### Electrical specifications

Operating voltage $U_B$	4.75 ... 30 V DC
	5 V DC for RS-422
No-load supply current $I_0$	max. 55 mA

### Output

Output type	push-pull, incremental or RS-422, incremental
Voltage drop $U_d$	$\leq 2.5$ V ( $< 2.5$ V)
Load current	max. per channel 30 mA, short-circuit protected (max. per channel 20 mA, conditionally short-circuit proof)
Output frequency	max. 100 kHz (max. 100 kHz)
Rise time	980 ns (225 ns)
De-energized delay $t_{off}$	980 ns (225 ns)

### Connection

Cable	$\varnothing 6$ mm, $8 \times 0.128$ mm <sup>2</sup> , 0.5 m
-------	--

### Standard conformity

Degree of protection	DIN EN 60529, IP40, IP54
Climatic testing	DIN EN 60068-2-3, no moisture condensation
Emitted interference	EN 61000-6-4:2007/A1:2011
Noise immunity	EN 61000-6-2:2005
Shock resistance	DIN EN 60068-2-27, 100 g, 6 ms
Vibration resistance	DIN EN 60068-2-6, 10 g, 10 ... 2000 Hz

### Ambient conditions

Operating temperature	-10 ... 70 °C (14 ... 158 °F)
Storage temperature	-40 ... 80 °C (-40 ... 176 °F)

### Mechanical specifications

Material	
Housing	aluminum, blank
Flange	3.1645 aluminum
Shaft	Stainless steel 1.4305 / AISI 303
Mass	approx. 220 g
Rotational speed	max. 6000 min <sup>-1</sup>
Moment of inertia	$\leq 5$ gcm <sup>2</sup>
Starting torque	$\leq 0.5$ Ncm
Shaft load	
Axial	20 N
Radial	40 N

### Approvals and certificates

UL approval	cULus Listed, General Purpose, Class 2 Power Source
-------------	---

**Dimensions**

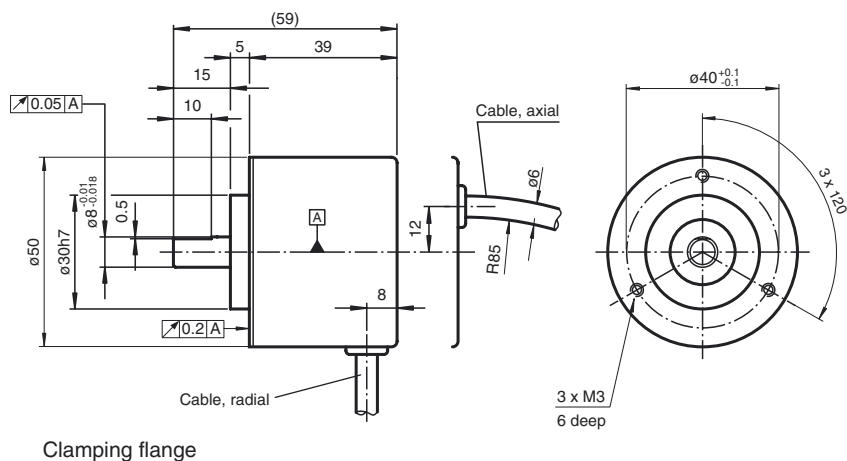

**Electrical connection**

Signal	Cable Ø6 mm, 8-core
GND	Blue
+U <sub>b</sub>	Brown
A	Black
B	White
$\bar{A}$	Violet
$\bar{B}$	Grey
0	Orange
$\bar{0}$	Yellow
Screen	-

Release date: 2014-12-11 09:19 Date of issue: 2014-12-11 121623\_eng.xml

Signal outputs

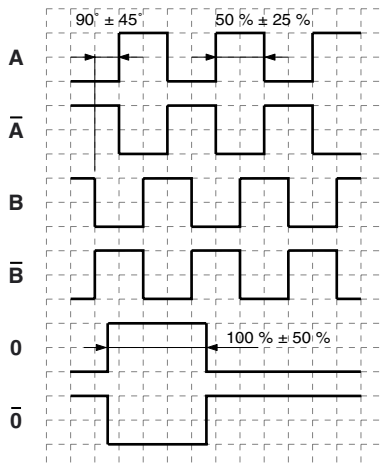

↻ cw - with view onto the shaft

Order code

T	V	I	5	0	N	-			B	K			6	T	N	-						
---	---	---	---	---	---	---	--	--	---	---	--	--	---	---	---	---	--	--	--	--	--	--

**Pulse count** 50, 100, 200, 360, 400, 500, 1000, 1024

**Option**  
N Normal

**Output switching**  
T 4.75 V ... 30 V, push-pull

**Signal output**  
6 A + B + 0 and  $\bar{A}$  +  $\bar{B}$  +  $\bar{0}$

**Exit position**  
A Axial  
R Radial

**Connection type**  
K0 Cable Ø6 mm, 8 x 0.128 mm<sup>2</sup>, 0.5 m  
K2 Cable Ø6 mm, 8 x 0.128 mm<sup>2</sup>, 2 m

**Flange version**  
B Clamping flange

**Shaft dimension**  
09 Shaft Ø8 mm x 15 mm  
14 Shaft Ø6 mm x 15 mm  
23 Shaft Ø5 mm x 15 mm

**Housing material**  
N Aluminium, IP40  
T Aluminium, IP54

**Shaft version**  
V Solid shaft

Release date: 2014-12-11 09:19 Date of issue: 2014-12-11 12:16:23\_eng.xml