



Model Number

ML7-6/59/102/115b/126b

Retroreflective sensor
with 0.2 m fixed cable and 4-pin, M12 connector

Features

- Reliable sensor for standard applications
- Miniature design with versatile mounting options
- Automatic adjustment of sensitivity via TEACH-IN
- Resistant against noise: reliable operation under all conditions
- Certified by ECOLAB

Product information

Small, robust, effective, and reliable - these are the properties of the ML7 sensor series. Due to their small size, number of versions, and two different lens positions, they are particularly suited for installation in tight spaces. The robust design and high quality of Pepperl+Fuchs mean they can also be used under harsh environmental conditions. The efficient technology, switching frequencies up to 1000 Hz, high resistance to ambient light, and 4-in-1 output make the series suitable for non-contact object detection.

Release date: 2013-04-18 14:37 Date of issue: 2013-05-13 t22533_eng.xml

Dimensions

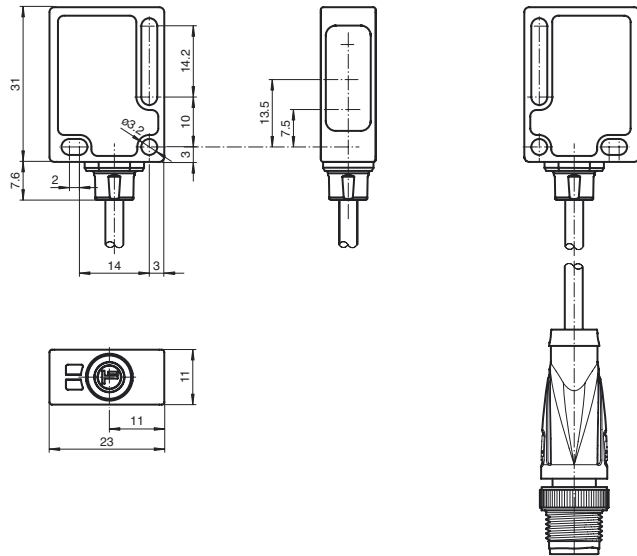

Electrical connection

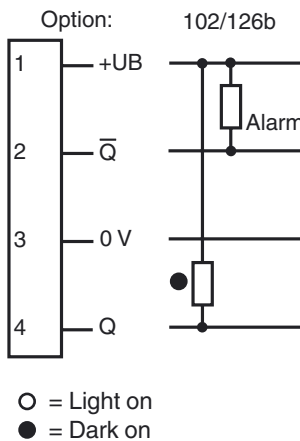

Pinout

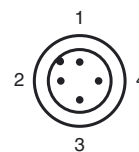

Indicators/operating means

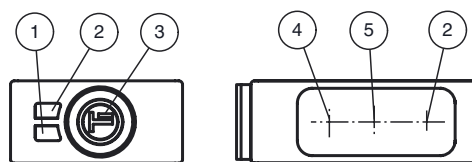

1	Operating display	green
2	Signal display	yellow
3	TEACH-IN button	
4	Emitter	
5	Receiver	

Technical data**General specifications**

Effective detection range	0 ... 3 m
Reflector distance	0.02 ... 3 m
Threshold detection range	3.5 m
Reference target	H85-2 reflector
Light source	LED
Light type	modulated visible red light
Diameter of the light spot	approx. 180 mm at a distance of 3.5 m
Angle of divergence	approx. 3 °
Ambient light limit	40000 Lux

Indicators/operating means

Operating display	LED green, flashes in case of short-circuit
Function display	LED yellow, lights up when light beam is free, flashes when falling short of the stability control
Controls	TEACH-IN key

Electrical specifications

Operating voltage	U_B	10 ... 30 V DC, class 2
Ripple		max. 10 %
No-load supply current	I_0	< 20 mA

Output

Pre-fault indication output	1 NPN, inactive after failure to achieve the stability control minimum for approx. 5 s Immediately inactive if 4 beam interruptions occur within the flashing period.	
Switching type	dark on	
Signal output	1 NPN output, short-circuit protected, reverse polarity protected, open collector	
Switching voltage	max. 30 V DC	
Switching current	max. 100 mA	
Voltage drop	U_d	≤ 1.5 V DC
Switching frequency	f	1000 Hz
Response time		0.5 ms

Ambient conditions

Ambient temperature	-20 ... 60 °C (-4 ... 140 °F)
Storage temperature	-40 ... 75 °C (-40 ... 167 °F)

Mechanical specifications

Protection degree	IP67 / IP69K
Connection	fixed cable 200 mm with M12 connector, 4-pin
Material	
Housing	PC (glass-fiber-reinforced Makrolon)
Optical face	PMMA
Mass	approx. 30 g

Compliance with standards and directives

Standard conformity	
Product standard	EN 60947-5-2:2007 IEC 60947-5-2:2007
Standards	EN 50178, UL 508

Approvals and certificates

Protection class	II, rated voltage ≤ 250 V AC with pollution degree 1-2 according to IEC 60664-1
UL approval	cULus

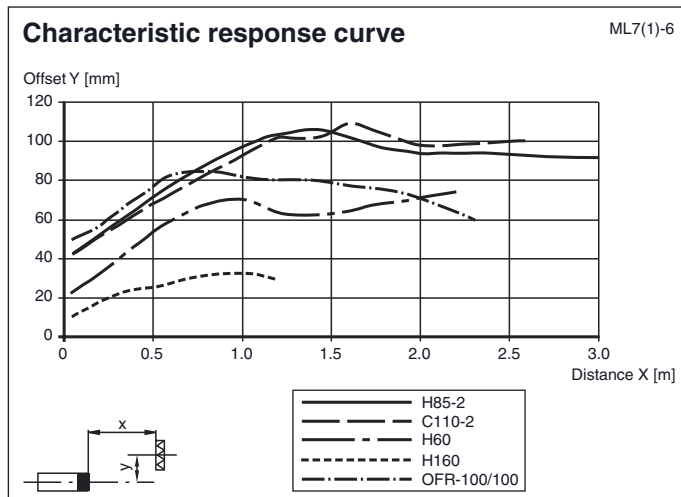
Curves/Diagrams**Accessories****Montagekit OMH-ML7-01**

Mounting set consisting of bracket OMH-ML-01 sheet OMH-ML7-03, and fastening material

Montagekit OMH-ML7-02

Mounting set consisting of bracket OMH-ML-02 sheet OMH-ML7-03, and fastening material

OMH-ML7-01

Mounting bracket

OMH-ML7-02

Mounting bracket

OMH-ML7-03

Fixing plate

Suitable reflectors and cable sockets can be found in the Internet

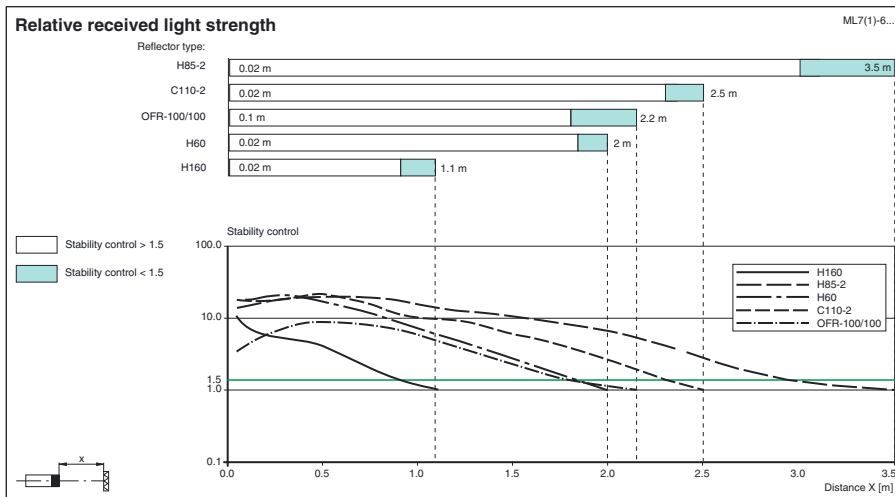

Teach-In

Connect the sensor to operating voltage, the LED green lights up constantly. The sensor operates at max. sensitivity (delivery status) or with the last taught values.

Mount suitable reflector opposite light beam switch.

- Adjust the unit to the reflector.
- Press the Teach-In button - as an acknowledgement the green LED will quickly turn off one time.
- Press the Teach-In button until both LEDs green and yellow are blinking in parallel (2Hz). Release the Teach-In button now.
- While the green and yellow LEDs are blinking alternating (2 Hz) the unit is in the internal set up procedure.
- **Teach-In successful:** Both LEDs green and yellow are on. The unit is ready to use and in switching mode now.
- **Teach-In not successful:** Both LEDs are flashing alternating (4 Hz) for approx. 5 seconds. Afterwards the sensor returns to max. sensitivity setting. Please retry the Teach-In procedure beginning by step 1.