

Model Number

14-14366

Features

- Up to 5000 ppr
- ATEX approval
- Flameproof enclosure
- 5 V with RS-422 interface

Description

Incremental rotary encoders of the series 14 have been specially developed for use in areas with a high level of mechanical demand.

The shaft is specially equipped with a feather key groove for receiving a belt pulley wheel. The permissible radial force is 80 N and the permissible axial force is 60 N.

One special feature is the mechanical versatility of the flange. The incremental rotary encoder has a centering collar with a diameter of 40 mm and one with a diameter of 80 mm. Three M6 holes are available for fastening.

The pulse disk is designed in plastic for up to 1500 pulses. Beyond that, glass is used.

Technical data

General specifications

Detection type	photoelectric sampling
Pulse count	max. 5000

Electrical specifications

Operating voltage U_B	5 V DC \pm 5 %
No-load supply current I_0	max. 150 mA

Output

Output type	RS 422, incremental
Load current	max. per channel 20 mA, conditionally short-circuit proof
Output frequency	max. 100 kHz
Rise time	100 ns
De-energized delay t_{off}	100 ns

Connection

Cable	\varnothing 11.2 mm, 9-core, 2 m
-------	------------------------------------

Standard conformity

Degree of protection	DIN EN 60529, IP66
Emitted interference	EN 61000-6-4:2007/A1:2011
Noise immunity	EN 61000-6-2:2005

Ambient conditions

Operating temperature	
Gas Ex-area	-40 ... 55 °C (-40 ... 131 °F)
Dust Ex-area	-30 ... 55 °C (-22 ... 131 °F)
Storage temperature	
Gas Ex-area	-40 ... 70 °C (-40 ... 158 °F)
Dust Ex-area	-30 ... 70 °C (-22 ... 158 °F)

Mechanical specifications

Material	
Housing	3.1645 aluminum
Flange	3.1645 aluminum
Shaft	Stainless steel 1.4305 / AISI 303
Mass	approx. 3000 g
Rotational speed	max. 6000 min ⁻¹
Moment of inertia	400 gcm ²
Starting torque	< 5 Ncm
Shaft load	
Axial	60 N
Radial	80 N

Data for application in connection with Ex-areas

EC-Type Examination Certificate	ZELM 02 ATEX 0078 X
Group, category, type of protection	II 2G Ex db IIC T6 Gb II 2D Ex tb IIIC T80°C Db IP66

Directive conformity	
Directive 94/9/EC	EN 60079-0:2012 EN 60079-1:2007 EN 60079-31:2009

Dimensions

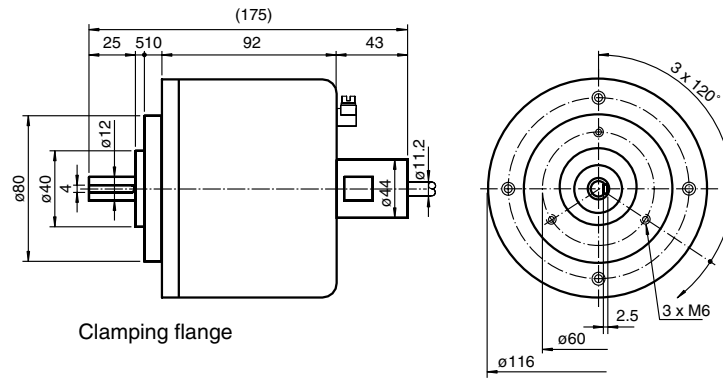

Clamping flange

Electrical connection

Signal	Cable $\phi 11.2$ mm, 9-core
GND	1
+U _b	2
A	3
B	4
\bar{A}	5
\bar{B}	6
0	7
$\bar{0}$	8
PE	Green/Yellow

Signal outputs

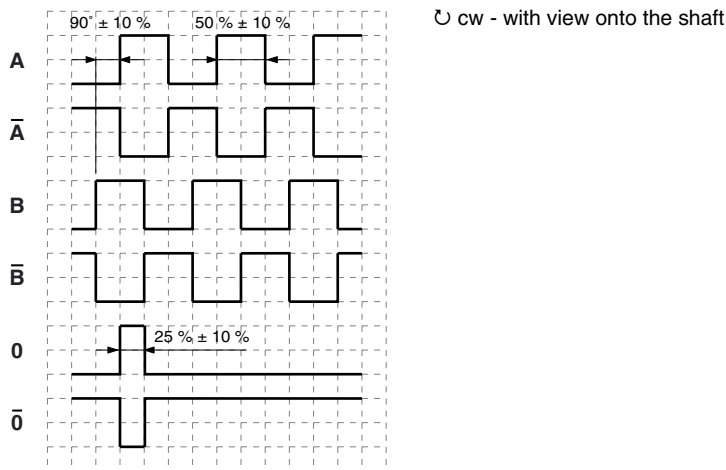

Order code

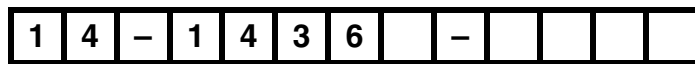

Pulse count 60, 100, 120, 180, 200, 250, 256, 300, 314, 360, 400, 500, 512, 600, 720, 900, 1000, 1024, 1200, 1250, 1500, 1800, 2000, 2048, 2400, 2500, 3000, 3600, 4000, 4096, 5000

Output switching

- 1 10 V ... 30 V, push-pull
- 6 5 V, RS 422
- X 10 V ... 30 V, RS 422

Signal output

36 $A + B + 0$ and $\bar{A} + \bar{B} + \bar{0}$

Release date: 2014-12-11 09:20 Date of issue: 2014-12-11 12484_eng.xml