



Model Number

FVM58

Features

- Industrial standard housing Ø58 mm
- 25-bit multiturn
- Output code: gray and binary
- Short-circuit proof push-pull output
- Inputs for selecting counting direction, LATCH, and PRESET
- Code change frequency up to 400 kHz
- Servo or clamping flange

Description

The emphasis for this series is on rapid data transfer. Position data are read directly out of the Gray code disc. The high code switching frequency of 400 kHz is achieved by consciously avoiding the use of a microcontroller.

In terms of the mechanics, designs with clamping flange or servo flange are available for the FVM58 multiturn absolute encoder.

Technical data

Functional safety related parameters

MTTF _d	110 a
Mission Time (T _M)	20 a
L _{10h}	1.9 E+11 at 6000 rpm and 20/40 N axial/radial shaft load
Diagnostic Coverage (DC)	0 %

Electrical specifications

Operating voltage U _B	10 ... 30 V DC
No-load supply current I ₀	max. 140 mA
Power consumption P ₀	≤ 2.5 W , without output drivers
Linearity	± 0.5 LSB
Output code	Gray code, binary code
Code course (counting direction)	cw ascending (clockwise rotation, code course ascending)
Code preparation time	0.3 ms

Interface

Interface type	Push-pull, parallel , short-circuit protected
Resolution	
Multiturn	25 Bit
Load current	20 mA
Voltage drop	≤ 2.5 V
Signal voltage	
High	operating voltage minus voltage drop
Low	≤ 2.8 V
Rise time	300 ns
De-energized delay	300 ns
Code change frequency	400 kHz

Input 1

Input type	Selection of counting direction (cw/ccw)
Signal voltage	
High	10 ... 30 V
Low	0 ... 2 V
Input current	< 6 mA
Signal duration	≥ 10 ms

Input 2

Input type	Temporary storage (LATCH)
Signal voltage	
High	10 ... 30 V
Low	0 ... 2 V
Input current	< 6 mA
Signal duration	≥ 100 μs
Switch-on delay	< 0.1 ms
Switch-off delay	< 0.1 ms

Input 3

Input type	zero-set (PRESET)
Signal voltage	
High	10 ... 30 V
Low	0 ... 2 V
Input current	< 6 mA
Signal duration	≥ 10 ms
Switch-on delay	< 1 ms

Connection

Connector	type 9426, 26-pin
Cable	Ø9 mm, 15 x 2 x 0.14 mm ² , 2 m

Standard conformity

Degree of protection	DIN EN 60529, IP65
Climatic testing	DIN EN 60068-2-3, no moisture condensation
Emitted interference	EN 61000-6-4:2007
Noise immunity	EN 61000-6-2:2005
Shock resistance	DIN EN 60068-2-27, 100 g, 6 ms
Vibration resistance	DIN EN 60068-2-6, 10 g, 10 ... 2000 Hz

Ambient conditions

Operating temperature	-40 ... 85 °C (-40 ... 185 °F) cable models: -30 ... 70 °C (rigid wiring) -5 ... 70 °C (flexible wiring)
Storage temperature	-40 ... 85 °C (-40 ... 185 °F) (cable models: -5 ... 70 °C)

Mechanical specifications

Material	
Combination 1	housing: powder coated aluminum flange: aluminum shaft: stainless steel
Combination 2 (Inox)	housing: stainless steel flange: stainless steel shaft: stainless steel
Mass	approx. 400 g (combination 1) approx. 800 g (combination 2)
Rotational speed	max. 12000 min ⁻¹
Moment of inertia	30 gcm ²
Starting torque	≤ 5 Ncm
Shaft load	
Axial	40 N
Radial	110 N

Dimensions

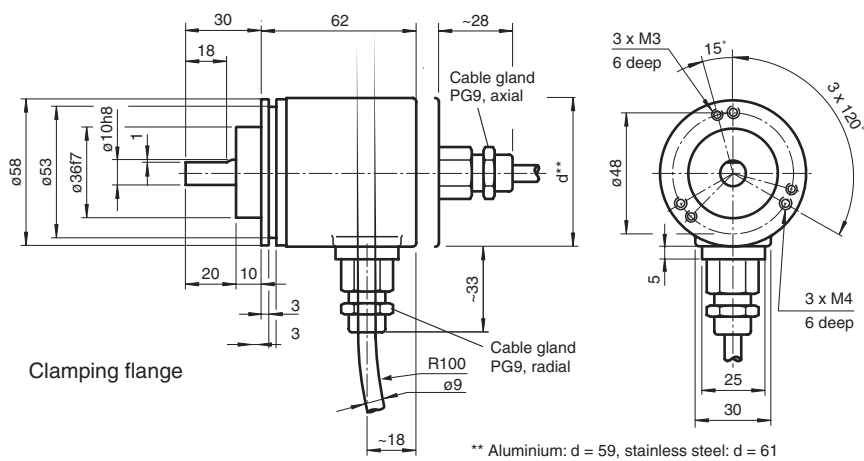
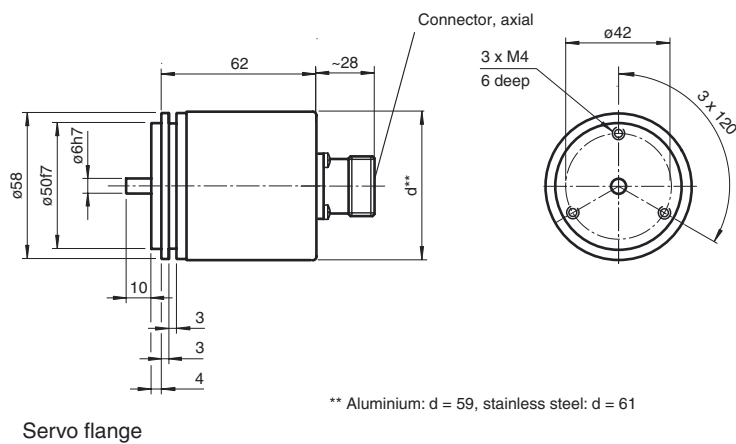
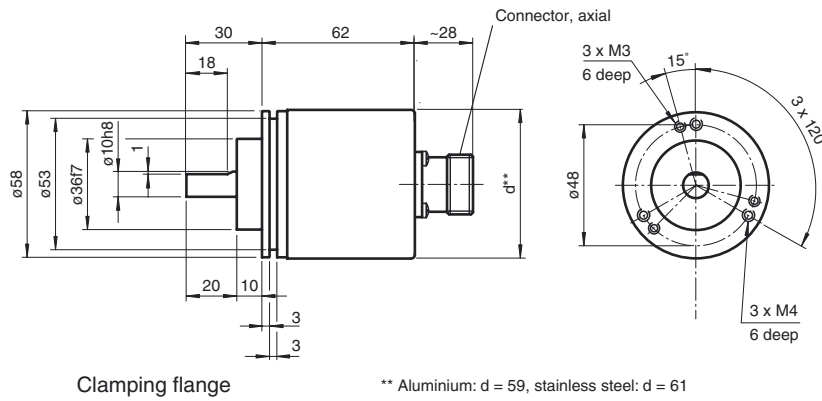

Release date: 2014-04-15 10:12 Date of issue: 2014-06-23 t25462_eng.xml

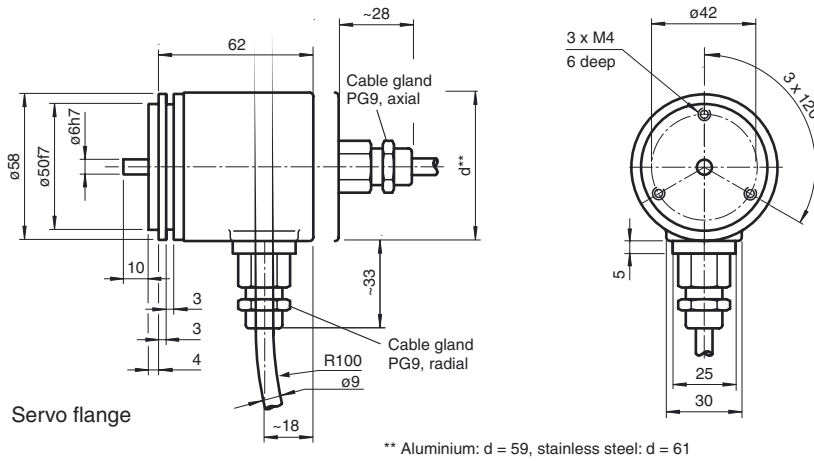

Electrical connection

Signal	Cable Ø9 mm, 30-core	Connector 9426, 26-pin	Explanation
GND (rotary encoder)	White	1	Power supply
U _c (rotary encoder)	Brown	2	Power supply
Bit 1	Green	3	Data output
Bit 2	Yellow	4	Data output
Bit 3	Grey	5	Data output
Bit 4	Pink	6	Data output
Bit 5	Blue	7	Data output
Bit 6	Red	8	Data output
Bit 7	Black	9	Data output
Bit 8	Violet	10	Data output
Bit 9	Grey/Pink	11	Data output
Bit 10	Red/Blue	12	Data output
Bit 11	White/Green	13	Data output
Bit 12	Brown/Green	14	Data output
Bit 13	White/Yellow	15	Data output
Bit 14	Yellow/Brown	16	Data output
Bit 15	White/Grey	17	Data output
Bit 16	Grey/Brown	18	Data output
Bit 17	White/Pink	19	Data output
Bit 18	Pink/Brown	20	Data output
Bit 19	White/Blue	21	Data output
Bit 20	Brown/Blue	22	Data output
Bit 21	White/Red	23	Data output
Bit 22	Brown/Red	-	Data output
Bit 23	White/Black	-	Data output
Bit 24	Brown/Black	-	Data output
Bit 25	Pink/Green	-	Data output
V/R	Grey/Green	25	Input for selection of counting direction
Latch	Yellow/Grey	24	Temporary storage input
PRESET	Yellow/Pink	26	Zero setting

Release date: 2014-04-15 10:12 Date of issue: 2014-06-23 t25462_eng.xml

Inputs

Input for temporary storage (LATCH)
Input zero setting (PRESET)

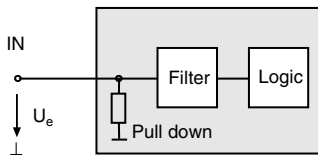

Input level: "0" 0 V ... 2 V,
"1" 10 V ... 30 V,
 $I_e < 6 \text{ mA}$

Input for selection of counting direction (V/R)

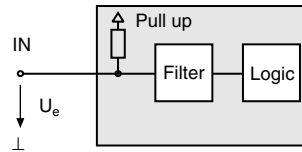

Input for selection of counting direction (V/R)

The counting direction for the absolute value rotary encoder as seen looking on the shaft is defined as right rotating (cw) rising or descending. The counting direction can be reversed with the V/R input. If the input is not used, the counting direction is defined as rising (standard), the level is at "1". Pulse duration $T > 10 \text{ ms}$.

Input level: "1" or unused = rising code value with direction of rotation cw.

Input level: "0" = descending code value for direction of rotation cw.

Input for temporary storage (LATCH)

With LATCH input "active", the position data on the parallel interface are "frozen". This makes it possible to accept position data without errors (especially for binary position data), since any change in the data during the read procedure is prevented. If this input is unused, its value is "0". Pulse duration $T > 100 \mu\text{s}$.

Input level: "1" = position data saved and stable at the output.

Input level: "0" or unused = position data free running at the output.

Input zero setting (PRESET)

By means of the PRESET input, the absolute value rotary encoder can be adjusted electronically to position value 0. Pulse duration $T > 10 \text{ ms}$.

Input level: "0" or unused = inactive.

Input level: "1" = Data output word is set to 0.

Accessories

For type	Accessories	Name/defining feature	Order code
FVM58N-011	Couplings	D1: Ø10 mm, D2: Ø10 mm	9401
		D1: Ø10 mm, D2: Ø10 mm	9404
		D1: Ø10 mm, D2: Ø10 mm	9409
		D1: Ø10 mm, D2: Ø10 mm	KW
	Measurement wheels with circumference of 500 mm	Plastic	9101, 10
		Pimpled rubber	9102, 10
		Knurled aluminium	9103, 10
		Knurled plastic	9112, 10
	Measurement wheels with circumference of 200 mm	Plastic	9108, 10
		Pimpled rubber	9109, 10
		Knurled aluminium	9110, 10
	Mounting aids	Knurled plastic	9113, 10
		Mounting bracket	9203
	FVM58N-032	Couplings	Mounting bracket
D1: Ø6 mm, D2: Ø6 mm			9401
D1: Ø6 mm, D2: Ø6 mm			9402
D1: Ø6 mm, D2: Ø6 mm			9404
D1: Ø6 mm, D2: Ø6 mm			9409
Mounting aids		2D1: Ø6 mm, D2: Ø6 mm	KW
		Mounting bracket and set	9300 and 9311-3
		Eccentric clamping elements	9310-3
All	Connector	Cable socket	9426

For additional information on the accessories, please see the "Accessories" section.

Order code

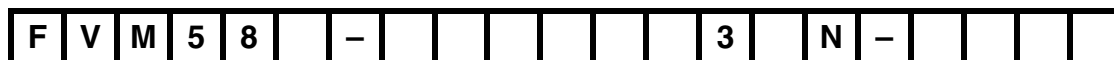

**Number of bits singleturn*
(Resolution)**
13 8192

**Number of bits multiturn*
(Revolutions)**
12 4096 (only connection type K2)
08 256

Temperature range
N Not expanded

Output code

- B Binary
- G Gray

Option 1

3 V/R, LATCH, PRESET

Exit position

- A Axial
- R Radial

Connection type

- K2 Cable Ø9 mm, 15 x 2 x 0.14 mm², 2 m
- AE Plug connector type 9426, 26-pin (only axial)

Shaft dimension/flange version

- 011 Shaft Ø10 mm x 20 mm with clamping flange
- 032 Shaft Ø6 mm x 10 mm with servo flange

Housing material

- N Aluminium, powder coated
- I Inox

Principle of operation

- M Multiturn

Shaft version

- V Solid shaft

Data format

- F Fast parallel

*) total number of bits (singleturn + multiturn) = 25 bit (cable version)
total number of bits (singleturn + multiturn) = 21 bit (plug connector version)