



Model Number

FSS58

Features

- Industrial standard housing Ø58 mm
- 13 Bit singleturn
- Output code: gray and binary
- Short-circuit proof push-pull output
- Inputs for selecting counting direction, LATCH, and PRESET
- Code change frequency up to 400 kHz
- Recessed hollow shaft

Description

The emphasis for this series is on rapid data transfer. Position data are read directly out of the Gray code disc. The high code switching frequency of 400 kHz is achieved by consciously avoiding the use of a microcontroller.

The FSS58 singleturn absolute encoder is equipped with a recessed hollow shaft. The encoder housing has a diameter of 58 mm. The recessed hollow shaft is available with diameters of 10 mm, 12 mm and 15 mm.

This version in particular represents a simple and cost-effective mounting solution. The shaft hub connection is already integrated into the rotary encoder. The rotary encoder is held in place by a torque rest.

Technical data

Functional safety related parameters

MTTF _d	120 a
Mission Time (T _M)	20 a
L _{10h}	1.9 E+11 at 6000 rpm and 20/40 N axial/radial shaft load
Diagnostic Coverage (DC)	0 %

Electrical specifications

Operating voltage U _B	10 ... 30 V DC
No-load supply current I ₀	max. 140 mA
Power consumption P ₀	≤ 2 W , without output drivers
Linearity	± 0.5 LSB
Output code	Gray code, binary code and Gray excess code
Code course (counting direction)	cw ascending (clockwise rotation, code course ascending)
Code preparation time	0.3 ms

Interface

Interface type	Push-pull, parallel , short-circuit protected
Resolution	
Single turn	13 Bit
Load current	20 mA
Voltage drop	≤ 2.5 V
Signal voltage	
High	operating voltage minus voltage drop
Low	≤ 2.8 V
Rise time	300 ns
De-energized delay	300 ns
Code change frequency	400 kHz

Input 1

Input type	Selection of counting direction (cw/ccw)
Signal voltage	
High	10 ... 30 V
Low	0 ... 2 V
Input current	< 6 mA
Signal duration	≥ 10 ms
Switch-on delay	≥ 1 ms
Switch-off delay	≥ 1 ms

Input 2

Input type	Temporary storage (LATCH)
Signal voltage	
High	10 ... 30 V
Low	0 ... 2 V
Input current	< 6 mA
Signal duration	≥ 100 µs
Switch-on delay	< 0.1 ms
Switch-off delay	< 0.1 ms

Input 3

Input type	zero-set (PRESET)
Signal voltage	
High	10 ... 30 V
Low	0 ... 2 V
Input current	< 6 mA
Signal duration	≥ 10 ms
Switch-on delay	< 1 ms

Connection

Connector	type 9424 (M23), 19-pin
Cable	Ø9 mm, 12 x 2 x 0.14 mm ² , 2 m

Standard conformity

Degree of protection	DIN EN 60529, IP65
Climatic testing	DIN EN 60068-2-3, no moisture condensation
Emitted interference	EN 61000-6-4:2007
Noise immunity	EN 61000-6-2:2005
Shock resistance	DIN EN 60068-2-27, 100 g, 6 ms
Vibration resistance	DIN EN 60068-2-6, 10 g, 10 ... 2000 Hz

Ambient conditions

Operating temperature	-40 ... 85 °C (-40 ... 185 °F) cable models: -30 ... 70 °C (rigid wiring) -5 ... 70 °C (flexible wiring)
Storage temperature	-40 ... 85 °C (-40 ... 185 °F) (cable models: -5 ... 70 °C)

Mechanical specifications

Material	
Combination 1	housing: powder coated aluminum flange: aluminum shaft: stainless steel
Combination 2 (Inox)	housing: stainless steel flange: stainless steel shaft: stainless steel
Mass	approx. 200 g (combination 1) approx. 400 g (combination 2)
Rotational speed	max. 12000 min ⁻¹
Moment of inertia	30 gcm ²
Starting torque	≤ 5 Ncm

Approvals and certificates

Release date: 2014-06-23 14:03 Date of issue: 2014-06-23 t26559_eng.xml

Refer to "General Notes Relating to Pepperl+Fuchs Product Information".

Dimensions

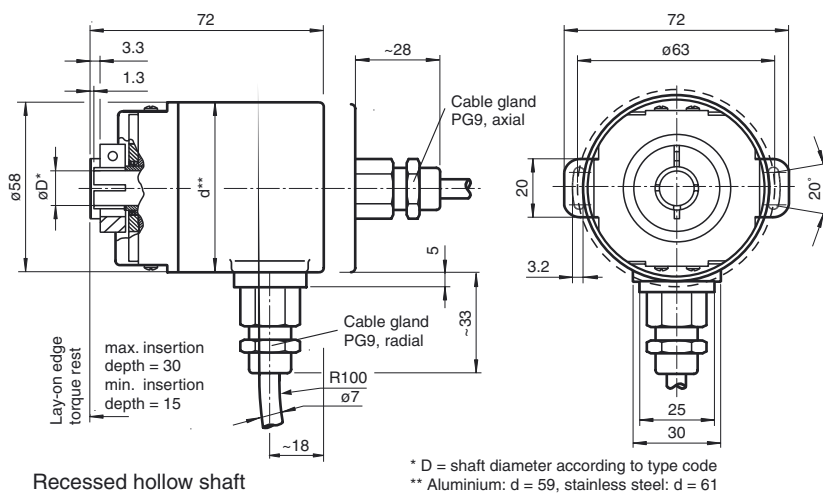
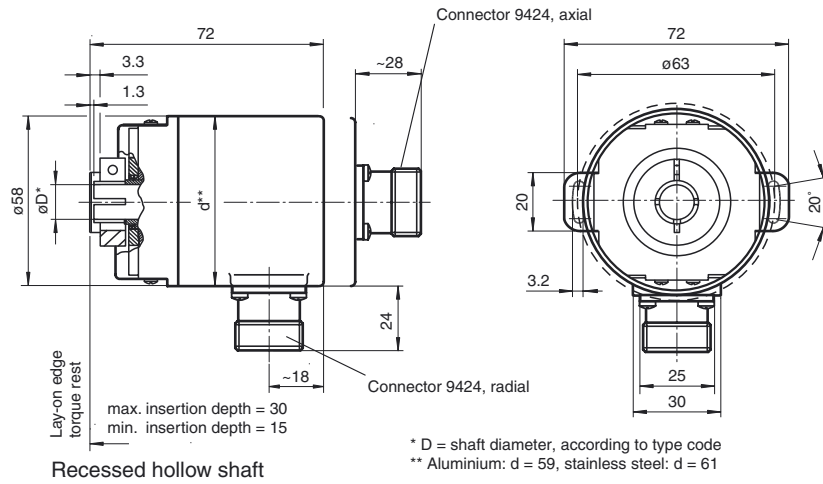

Release date: 2014-06-23 14:03 Date of issue: 2014-06-23 t26559_eng.xml

Electrical connection

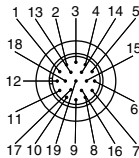
Signal	Cable Ø9 mm, 24-core	Connector 9424, 19-pin	Explanation
GND (rotary encoder)	White	6	Power supply
U _b (rotary encoder)	Brown	12	Power supply
Data bit 1	Green	1	Data output
Data bit 2	Yellow	2	Data output
Data bit 3	Grey	3	Data output
Data bit 4	Pink	4	Data output
Data bit 5	Blue	5	Data output
Data bit 6	Red	7	Data output
Data bit 7	Black	8	Data output
Data bit 8	Violet	9	Data output
Data bit 9	Grey/Pink	10	Data output
Data bit 10	Red/Blue	11	Data output
Data bit 11	White/Green	13	Data output
Data bit 12	Brown/Green	14	Data output
Data bit 13	White/Yellow	15	Data output
	White/Grey	-	Reserved
	Grey/Brown	19	Reserved
V/R	White/Pink	16	Input for selection of counting direction
LATCH	Pink/Brown	17	Temporary storage input
	White/Blue	-	Reserved
PRESET	Brown/Blue	18	Zero setting input
	White/Red	-	Reserved
	Brown/Red	-	Reserved
			

Release date: 2014-06-23 14:03 Date of issue: 2014-06-23 t26559_eng.xml

Inputs

Input for temporary storage (LATCH)
Input zero setting (PRESET)

Input level: "0" 0 V ... 2 V,
"1" 10 V ... 30 V,
 $I_e < 6 \text{ mA}$

Input for selection of counting direction (V/R)

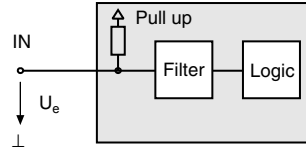
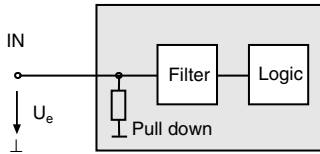

Input for selection of counting direction (V/R)

The counting direction for the absolute value rotary encoder as seen looking on the shaft is defined as right rotating (cw) rising or descending. The counting direction can be reversed with the V/R input. If the input is not used, the counting direction is defined as rising (standard), the level is at "1". Pulse duration $T > 10 \text{ ms}$.

Input level: "1" or unused = rising code value with direction of rotation cw.

Input level: "0" = descending code value for direction of rotation cw.

Input for temporary storage (LATCH)

With LATCH input "active", the position data on the parallel interface are "frozen". This makes it possible to accept position data without errors (especially for binary position data), since any change in the data during the read procedure is prevented. If this input is unused, its value is "0". Pulse duration $T > 100 \mu\text{s}$.

Input level: "1" = position data saved and stable at the output.

Input level: "0" or unused = position data free running at the output.

Input zero setting (PRESET)

By means of the PRESET input, the absolute value rotary encoder can be adjusted electronically to position value 0. Pulse duration $T > 10 \text{ ms}$.

Input level: "0" or unused = inactive.

Input level: "1" = Data output word is set to 0.

Order code



- Number of bits singleturn**
13 8192
- Option 2**
N Not expanded
- Output code**
B Binary
G Gray
- Option 1**
3 V/R, LATCH, PRESET
- Exit position**
A Axial
R Radial
- Connection type**
K2 Cable Ø9 mm, 12 x 2 x 0.14 mm², 2 m*
AD Plug connector type 9424, 19-pin
- Shaft dimension/flange version**
F1A Recessed hollow shaft Ø10 mm x 30 mm
F2A Recessed hollow shaft Ø12 mm x 30 mm
F3A Recessed hollow shaft Ø15 mm x 30 mm
- Housing material**
N Aluminium, powder coated
I Inox*
- Principle of operation**
S Singleturn
- Shaft version**
S Recessed hollow shaft
- Data format**
F Fast parallel

* Housing material I only available with axial exit position

Release date: 2014-06-23 14:03 Date of issue: 2014-06-23 t26559_eng.xml