



Model Number

TSI40N

Features

- Compact design
- Up to 1024 ppr
- 4.75 V ... 30 V with short-circuit proof push-pull output
- RS 422 functionality at 5 V operation
- Tangential cable outlet

Description

The TVI40 continues the new economical target line of Pepperl+Fuchs with a recessed hollow shaft version. With a small outside diameter of 40 mm, the unit is ideal for use in industrial areas where very little space is available.

The technology of the rotary encoder is adapted to the new requirements of the rotary encoder market. Innovative fast technology with Opto-ASIC forms the central basis of the device. The rotary encoder is available with a pulse count of up to 1024 pulses per revolution.

The rotary encoder provides the ideal combination of non-sensitivity to temperature and high resolution.

The appearance of this rotary encoder is the tangential cable outlet. This ensures a buckling-free, carefully laying of the connection cable in tangential, radial or axial manner.

Technical data

General specifications

Detection type	photoelectric sampling
Pulse count	max. 1024

Electrical specifications

Operating voltage U_B	4.75 ... 30 V DC
	5 V DC for RS-422
No-load supply current I_0	max. 55 mA

Output

Output type	push-pull, incremental or RS-422, incremental
Voltage drop U_d	≤ 2.5 V (< 2.5 V)
Load current	max. per channel 30 mA, short-circuit protected (max. per channel 20 mA, conditionally short-circuit proof)
Output frequency	max. 100 kHz (max. 100 kHz)
Rise time	980 ns (225 ns)
De-energized delay t_{off}	980 ns (225 ns)

Connection

Cable	$\varnothing 6$ mm, 8 x 0.128 mm ² , 0.5 m
-------	---

Standard conformity

Degree of protection	DIN EN 60529, IP54
Climatic testing	DIN EN 60068-2-3, no moisture condensation
Emitted interference	EN 61000-6-4:2007/A1:2011
Noise immunity	EN 61000-6-2:2005
Shock resistance	DIN EN 60068-2-27, 100 g, 6 ms
Vibration resistance	DIN EN 60068-2-6, 10 g, 10 ... 2000 Hz

Ambient conditions

Operating temperature	-10 ... 70 °C (14 ... 158 °F)
Storage temperature	-25 ... 85 °C (-13 ... 185 °F)

Mechanical specifications

Shaft dimensions $\varnothing \times l$	see type code
Material	
Housing	Polycarbonate
Flange	3.1645 aluminum
Shaft	Stainless steel 1.4305 / AISI 303
Mass	approx. 180 g
Rotational speed	max. 6000 min ⁻¹
Moment of inertia	≤ 4.3 gcm ²
Starting torque	≤ 0.2 Ncm
Shaft load	
Angle offset	1 °
Axial offset	max. 1 mm
Life span	$\geq 2 \times 10^9$ revolutions (max. shaft loading)

Approvals and certificates

UL approval	cULus Listed, General Purpose, Class 2 Power Source
-------------	---

Dimensions

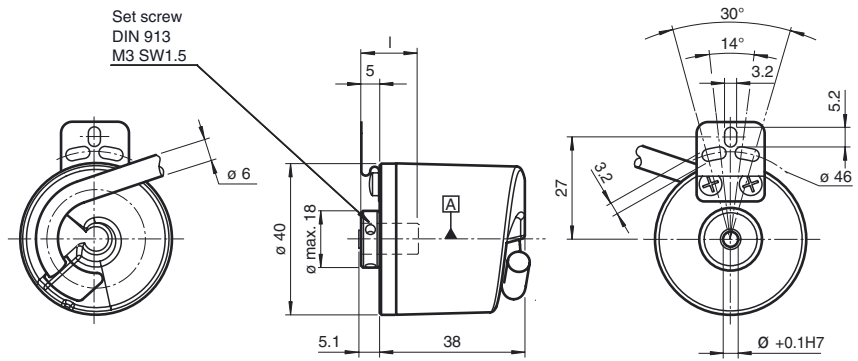

Electrical connection

Signal	Cable Ø6 mm, 8-core
GND	Blue
+U _b	Brown
A	Black
B	White
\bar{A}	Violet
\bar{B}	Grey
0	Orange
$\bar{0}$	Yellow
Screen	-

Signal outputs

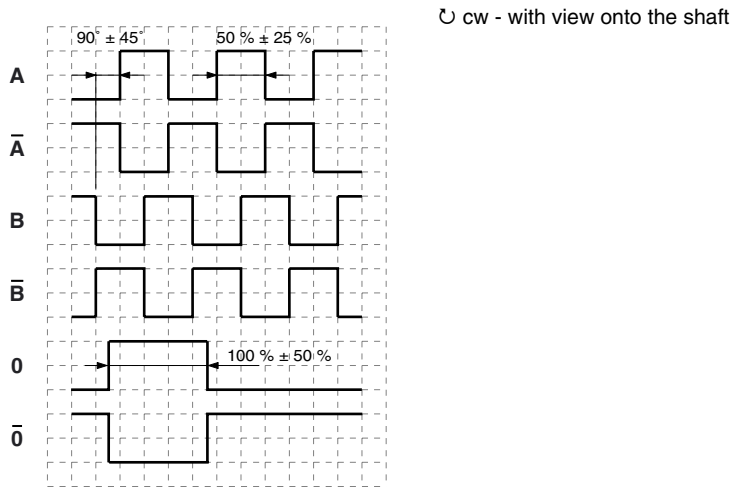

Order code

T	S	I	4	0	N	-				K		T	6	T	N	-							
---	---	---	---	---	---	---	--	--	--	---	--	---	---	---	---	---	--	--	--	--	--	--	--

Pulse count 25, 50, 100, 150, 180, 200, 250, 360, 400, 500, 600, 1000, 1024

Temperature range
 N normal

Output switching
 T 4,75 V ... 30 V, push-pull

Signal output
 6 A + B + 0 and $\bar{A} + \bar{B} + \bar{0}$

Exit position
 T tangential

Connection type
 K0 cable Ø6 mm, 8 x 0.128 mm², 0.5 m
 K2 cable Ø6 mm, 8 x 0.128 mm², 2 m

Shaft dimensions/flange type
 16A Recessed hollow shaft Ø4 mm x 15 mm
 14A Recessed hollow shaft Ø6 mm x 15 mm
 17A Recessed hollow shaft Ø1/4" x 15 mm
 27A Recessed hollow shaft Ø8 mm x 15 mm
 20A Recessed hollow shaft Ø3/8" x 15 mm
 21A Recessed hollow shaft Ø3/16" x 15 mm
 22A Recessed hollow shaft Ø5/16" x 15 mm

Housing material
 N Plastic

Shaft version
 S Recessed hollow shaft

Release date: 2015-02-12 10:00 Date of issue: 2015-02-12 t30768_eng.xml