



## Model Number

RVS58S-\*\*\*\*\*Z

## Features

- **Safe rotary encoder, thanks to integrated functional safety**
- **Usable up to SIL 3 acc. to IEC 61508**
- **TÜV certified**
- **Suitable as motor feedback system for safe drives in accordance with IEC 61800-5-2**
- **Incremental encoder with sin/cos interface**
- **1024 or 2048 signal periods**
- **Thermally stabilized with the highest precision for high resolution interpolation**

## Description

The RVS58S – a combination of precision and integrated safety technology for demanding requirements.

The RVS58S rotary encoder is suitable for use in safety-aligned systems up to

- SIL3 in accordance with IEC 61508
- Performance Level e in accordance with IEC 13849
- Category 4 in accordance with DIN EN 954-1

given the corresponding prerequisites with regard to the diagnostic capability of the higher-level control/evaluation system.

Typical applications for this rotary encoder are found in safety-evaluated drive technology (Motor feedback). Thanks to the 1 V<sub>SS</sub> sine/cosine interface the RVS58S is compatible with the current drive converters available on the market, as are required for the fine positioning of drives and servo-drive systems in industrial applications.

A clear increase in precision and the smooth running of the drive at an attractive price, including certificated safety in accordance with the applicable standards, enable this rotary encoder to be used in a wide variety of applications.

## Technical data

### General specifications

Detection type	photoelectric sampling
Pulse count	1024 and 2048

### Functional safety related parameters

Safety Integrity Level (SIL)	SIL 3
Performance level (PL)	PL e
MTTF <sub>d</sub>	709 a
Mission Time (T <sub>M</sub> )	10 a
PFH <sub>d</sub>	4.35 E-9
PFD	3.1 E-5
L <sub>10h</sub>	70 E+9 at 6000 rpm
Diagnostic Coverage (DC)	98.9 %

### Electrical specifications

Operating voltage U <sub>B</sub>	5 V DC ± 5 %
No-load supply current I <sub>0</sub>	max. 70 mA

### Output

Output type	sine / cosine
Amplitude	1 V <sub>SS</sub> ± 10 %
Load current	max. per channel 10 mA , short-circuit protected, reverse polarity protected
Output frequency	max. 200 kHz (3 dB limit)

### Connection

Cable	Ø6.5 mm, 4 x 2 x 0.14 mm <sup>2</sup> , 1 m
-------	---

### Standard conformity

Degree of protection	DIN EN 60529, IP65
Climatic testing	DIN EN 60068-2-78 , no moisture condensation
Emitted interference	EN 61000-6-4:2007/A1:2011
Noise immunity	DIN EN 61000-6-2 , advanced testing level to IEC 61326-3-1
Shock resistance	DIN EN 60068-2-27, 100 g, 3 ms
Vibration resistance	DIN EN 60068-2-6, 10 g, 55 ... 2000 Hz
Functional safety	IEC 61508:2000 IEC 62061:2005 ISO 13849-1:2006 IEC 61800-5-2:2007 EN 50178:1997 IEC 61326-3-1:2007 Suitable up to SIL 3, PL e depending from configuration, see manual and report

### Ambient conditions

Operating temperature	-5 ... 80 °C (23 ... 176 °F) , movable cable -20 ... 80 °C (-4 ... 176 °F), fixed cable
Storage temperature	-40 ... 100 °C (-40 ... 212 °F)

### Mechanical specifications

Material	
Housing	powder coated aluminum
Flange	3.1645 aluminum
Shaft	Stainless steel 1.4305 / AISI 303
Mass	approx. 350 g
Rotational speed	max. 12000 min <sup>-1</sup>
Moment of inertia	≤ 25 gcm <sup>2</sup>
Starting torque	≤ 1.5 Ncm
Shaft load	
Axial	40 N at max. 6000 min <sup>-1</sup> 10 N at max. 12000 min <sup>-1</sup>
Radial	60 N at max. 6000 min <sup>-1</sup> 20 N at max. 12000 min <sup>-1</sup>

### Approvals and certificates

UL approval	cULus Listed, General Purpose, Class 2 Power Source
-------------	---

**Dimensions**

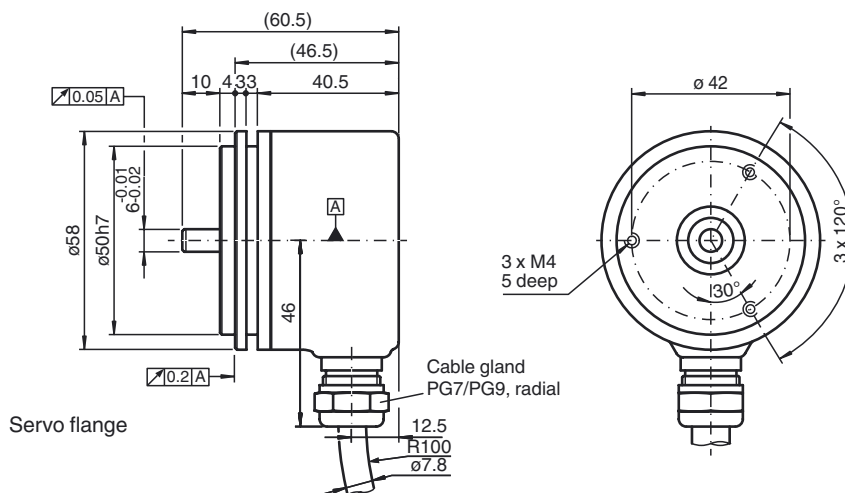

**Electrical connection**

Signal	Cable Ø6.5 mm, 8-core
GND	White
$U_b$	Brown
A / cos	Green
B / sin	Grey
$\bar{A}$ / $\overline{\text{cos}}$	Yellow
$\bar{B}$ / $\overline{\text{sin}}$	Pink
0	Blue
$\bar{0}$	Red
Screen	-

**Signal outputs**

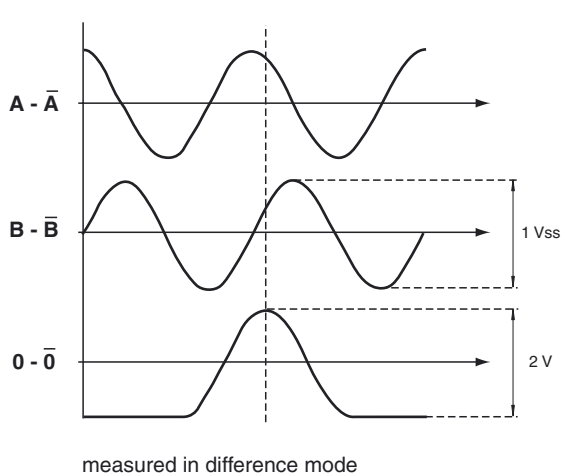

↻ cw - flange view

Release date: 2014-12-11 09:16 Date of issue: 2014-12-11 141131\_eng.xml

**Order code**

R	V	S	5	8	S	-						K	1	R	6	Z	N	-									
---	---	---	---	---	---	---	--	--	--	--	--	---	---	---	---	---	---	---	--	--	--	--	--	--	--	--	--

