



Model Number

ASS36M-*****

Features

- Very small housing
- High climatic resistance
- Up to 13 Bit singleturn
- SSI interface
- Optically isolated interface
- Surge and reverse polarity protection

Description

This singleturn absolute encoder transmits a position value corresponding to the shaft setting via the SSI interface (Synchronous Serial Interface).

The ASS36M series are encoders with internal magnetic sampling.

The control module sends a start sequence to the absolute encoder to obtain the position data. The rotary encoder then sends the position data synchronous to the cycles of the control module. It is possible to select the counting direction with the function input.

Technical data

General specifications

| | |
|----------------|-----------------------------|
| Detection type | magnetic sampling |
| Device type | Singleturn absolute encoder |

Electrical specifications

| | |
|----------------------------------|------------------------|
| Operating voltage U_B | 4.5 ... 30 V DC |
| Power consumption P_0 | approx. 2 W |
| Output code | Gray code, binary code |
| Code course (counting direction) | adjustable |

Interface

| | |
|---------------------|------------------------------------|
| Interface type | SSI |
| Resolution | |
| Single turn | up to 13 Bit (hysteresis: 0.1 °) |
| Overall resolution | up to 13 Bit |
| Transfer rate | 0.1 ... 2 MBit/s |
| Cycle time | < 600 μ s |
| Standard conformity | RS 422 |

Input 1

| | |
|-----------------|--|
| Input type | Selection of counting direction (cw/ccw) |
| Signal voltage | |
| High | 4.5 V ... U_B (cw descending) |
| Low | 0 ... 2 V or unconnected (cw ascending) |
| Input current | < 6 mA |
| Switch-on delay | < 1.1 s |

Input 2

| | |
|-----------------|---------------------------------------|
| Input type | zero-set (PRESET 1) with falling edge |
| Signal voltage | |
| High | 4.5 V ... U_B |
| Low | 0 ... 2 V |
| Input current | < 6 mA |
| Signal duration | \geq 1.1 s |

Connection

| | |
|-----------|--|
| Connector | M12 connector, 8-pin |
| Cable | \varnothing 6 mm, 4 x 2 x 0.14 mm ² , 1 m |

Standard conformity

| | |
|----------------------|--|
| Degree of protection | acc. DIN EN 60529 |
| Connection side | cable models: IP54 connector models: IP65 |
| Shaft side | IP54 |
| Climatic testing | DIN EN 60068-2-3, no moisture condensation |
| Emitted interference | EN 61000-6-4:2007 |
| Noise immunity | EN 61000-6-2:2005 |
| Shock resistance | DIN EN 60068-2-27, 100 g, 6 ms |
| Vibration resistance | DIN EN 60068-2-6, 10 g, 10 ... 1000 Hz |

Ambient conditions

| | |
|-----------------------|--|
| Operating temperature | cable, flexing: -5 ... 70 °C (-23 ... 158 °F), cable, fixed: -30 ... 70 °C (-22 ... 158 °F) connector models: -30 ... 85 °C (-22 ... 185 °F) |
| Storage temperature | cable models: -30 ... 70 °C (-22 ... 158 °F) connector models: -30 ... 85 °C (-22 ... 185 °F) |
| Relative humidity | 98 % , no moisture condensation |

Mechanical specifications

| | |
|-------------------|------------------------------|
| Material | |
| Housing | nickel-plated steel |
| Flange | aluminum |
| Shaft | Stainless steel |
| Mass | approx. 150 g , with cable |
| Rotational speed | max. 12000 min ⁻¹ |
| Moment of inertia | 30 gcm ² |
| Starting torque | < 3 Ncm |
| Shaft load | |
| Axial | 40 N |
| Radial | 110 N |

Dimensions

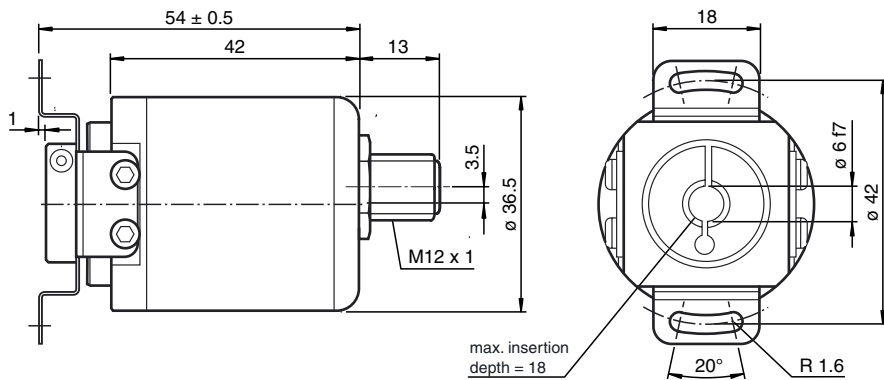
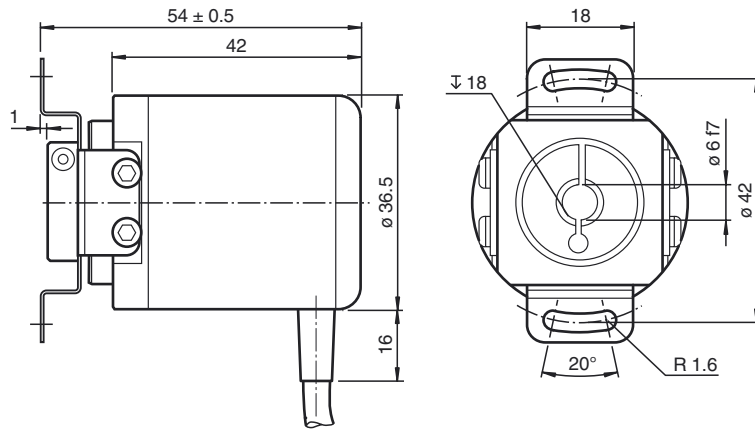
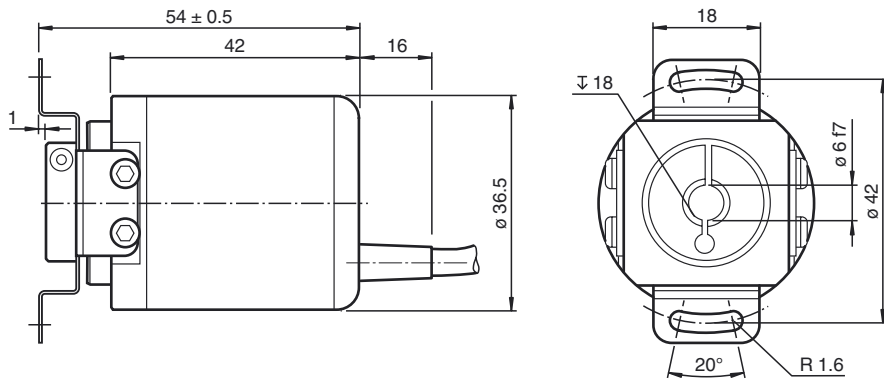

Recessed hollow shaft

Release date: 2014-04-14 15:30 Date of issue: 2014-04-14 142540_eng.xml

Electrical connection

| Signal | Wire end | Connector |
|--------------------------|---------------|---|
| GND (encoder) | White | 1 |
| U _b (encoder) | Brown | 2 |
| Clock (+) | Green | 3 |
| Clock (-) | Yellow | 4 |
| Data (+) | Grey | 5 |
| Data (-) | Pink | 6 |
| Preset | Black or Blue | 7 |
| Counting direction | Red | 8 |
| Shielding | Shielding | Housing |
| Pinout | - |  |

Release date: 2014-04-14 15:30 Date of issue: 2014-04-14 t42540_eng.xml

Description

The Synchronous Serial Interface was specially developed for transferring the output data of an absolute encoder to a control device. The control module sends a clock bundle and the absolute encoder responds with the position value.

Thus only 4 lines are required for the clock and data, no matter what the resolution of the rotary encoder is. The RS 422 interface is optically isolated from the power supply.

SSI signal course Standard

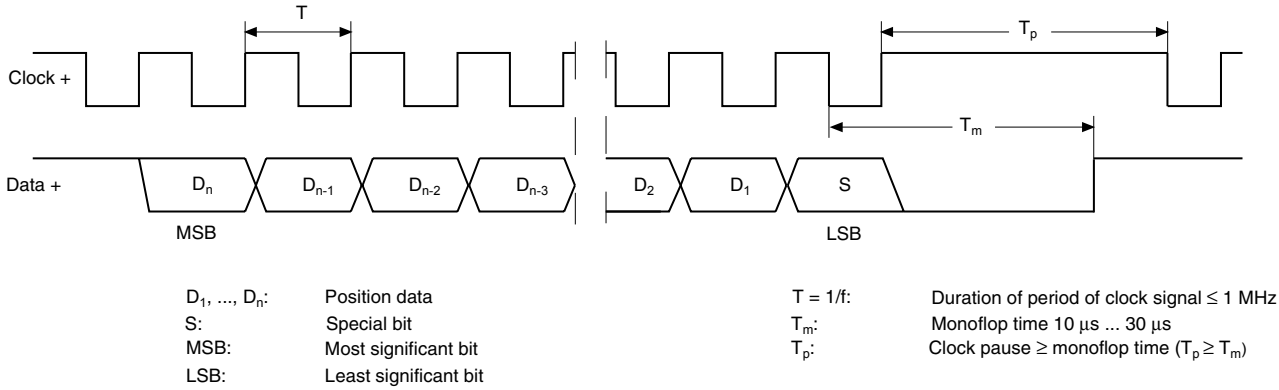

SSI output format Standard

- At idle status signal lines "Data +" and "Clock +" are at high level (5 V).
- The first time the clock signal switches from high to low, the data transfer in which the current information (position data (D_n) and special bit (S)) is stored in the encoder is introduced.
- The highest order bit (MSB) is applied to the serial data output of the encoder with the first rising pulse edge.
- The next successive lower order bit is transferred with each following rising pulse edge.
- After the lowest order bit (LSB) has been transferred the data line switches to low until the monoflop time T_m has expired.
- No subsequent data transfer can be started until the data line switches to high again or the time for the clock pause T_p has expired.
- After the clock sequence is complete, the monoflop time T_m is triggered with the last falling pulse edge.
- The monoflop time T_m determines the lowest transmission frequency.

SSI output format ring slide operation (multiple transmission)

- In ring slide operation, multiple transmission of the same data word over the SSI interface makes it possible to offer the possibility of detecting transmission errors.
- In multiple transmission, 25 bits are transferred per data word in standard format.
- If the clock change is not interrupted after the last falling pulse edge, ring slide operation automatically becomes active. This means that the information that was stored at the time of the first clock change is generated again.
- After the first transmission, the 26th pulse controls data repetition. If the 26th pulse follows after an amount of time greater than the monoflop time T_m , a new current data word will be transmitted with the following pulses.



If the pulse line is exchanged, the data word is generated offset. Ring slide operation is possible up to max. 13 bits.

Block diagram

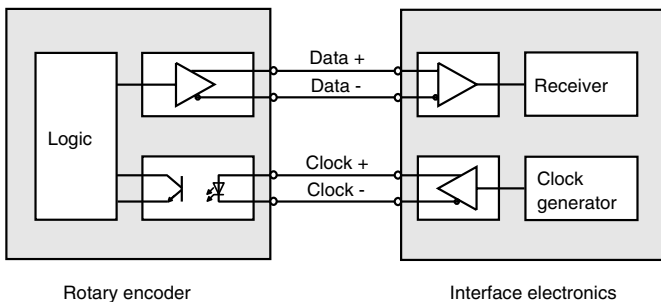

Line length

| Line length in m | Baudrate in kHz |
|------------------|-----------------|
| < 50 | < 400 |
| < 100 | < 300 |
| < 200 | < 200 |
| < 400 | < 100 |

Release date: 2014-04-14 15:30 Date of issue: 2014-04-14 142540_eng.xml

Order code

| | | | | | | | | | | | | | | | | | | | |
|---|---|---|---|---|---|---|---|---|---|--|--|---|--|---|---|---|---|--|--|
| A | S | S | 3 | 6 | M | - | F | 4 | A | | | 0 | | N | - | 0 | 0 | | |
|---|---|---|---|---|---|---|---|---|---|--|--|---|--|---|---|---|---|--|--|

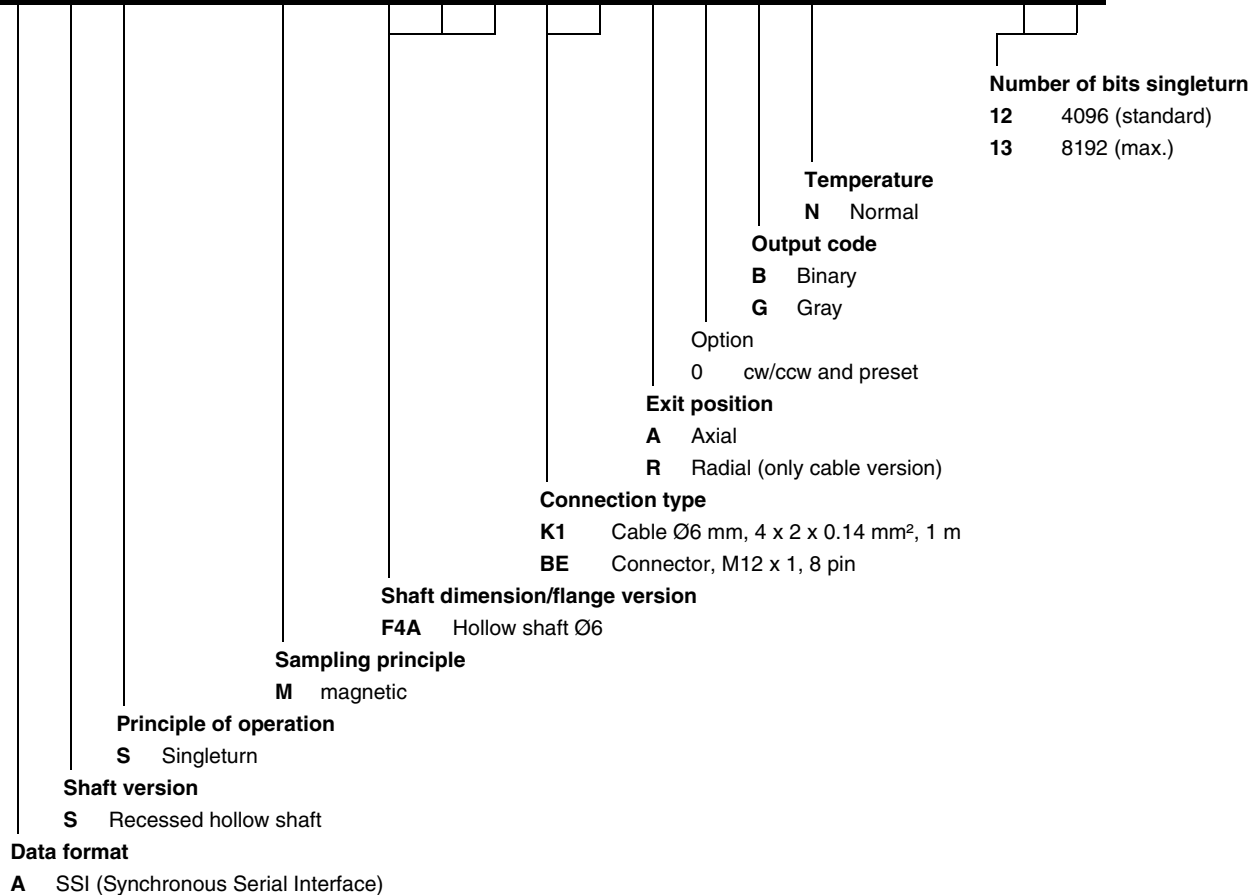

Release date: 2014-04-14 15:30 Date of issue: 2014-04-14 t42540_eng.xml