



### Model Number

**MNI40N**

Magnetic, Non Contact

### Features

- **Clear function verification via two-color LEDs (red/green)**
- **Simple installation and adjustment using assistance functions reduce costs**
- **Self-diagnostics including the magnetic wheel provide quality assurance**
- **Internal intelligence provides easy setup and reliable operation**
- **The elastomer coating of the magnetic wheel provides resistance to dirt as well as thermal and mechanical shock**
- **Long service life at high speeds and temperatures**

### Description

The magnetic incremental encoder MNI40 combines an exceptionally robust measurement system with intelligent diagnosis and alignment functions in the smallest space. Its highly compact encapsulated housing gives the sensor its high resistance to harsh environmental conditions. The installation-friendly design and simple guided adjustment of the sensor using two-color status LED reduces the installation time considerably.

Release date: 2014-12-19 10:28 Date of issue: 2014-12-19 t42651\_eng.xml

## Technical data

### General specifications

Detection type	magnetic sampling
Pulse count	max. 7200

### Functional safety related parameters

MTTF <sub>d</sub>	942 a
Mission Time (T <sub>M</sub> )	20 a
Diagnostic Coverage (DC)	0 %

### Indicators/operating means

LED red/green	Operating display / Alignment aid
---------------	-----------------------------------

### Electrical specifications

Operating voltage U <sub>B</sub>	10 ... 30 V DC 5 V DC for RS-422
No-load supply current I <sub>0</sub>	max. 55 mA

### Output

Output type	push-pull, incremental or RS-422, incremental
Voltage drop U <sub>d</sub>	≤ 2.5 V (< 2.5 V)
Load current	max. per channel 30 mA , short-circuit protected (max. per channel 20 mA, conditionally short-circuit proof)
Output frequency	max. 1 MHz

### Connection

Cable	Ø4.7 mm, 8 x 0.128 mm <sup>2</sup> , 2 m
-------	--

### Standard conformity

Degree of protection	DIN EN 60529, IP67 , IP68 , IP69K
Climatic testing	DIN EN 60068-2-30
Emitted interference	EN 61000-6-4:2007/A1:2011
Noise immunity	EN 61000-6-2:2005
Shock resistance	DIN EN 60068-2-27, 200 g, 6 ms
Vibration resistance	DIN EN 60068-2-6, 40 g, 10 ... 2000 Hz

### Ambient conditions

Operating temperature	-40 ... 100 °C (-40 ... 212 °F)
Storage temperature	-40 ... 100 °C (-40 ... 212 °F)

### Mechanical specifications

Material	
Housing	PA
Cable	PUR
Magnetic wheel	steel 1.4021 (AISI 420) ferrite filled cured rubber
Mass	approx. 190 g
Rotational speed	max. 30000 min <sup>-1</sup>

**Dimensions**

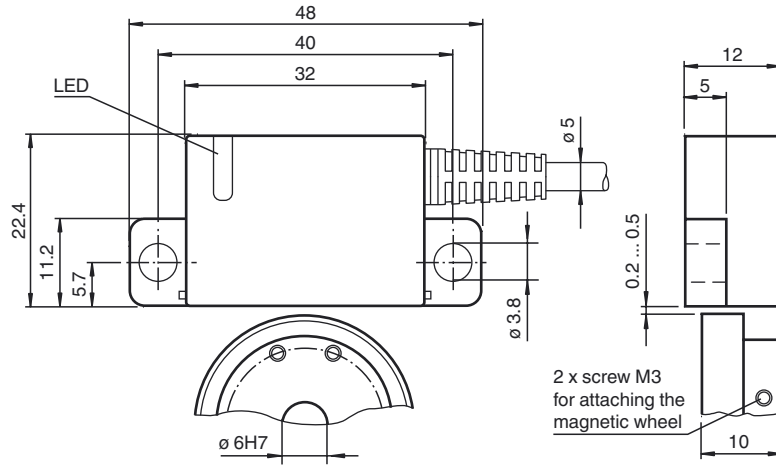

Poles	Ø d [mm]	Ø D [mm]	X [mm]
50	6	31.7	21.9
	10		
	12		
	15		
64	6	40.6	26.35
	10		
	12		
	15		
72	6	45.7	28.9
	10		
	12		
	15		

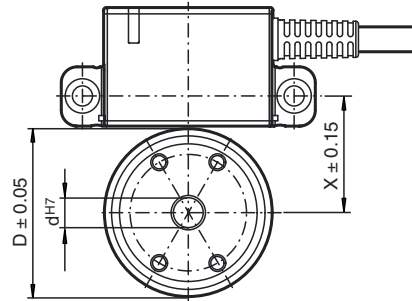

**Installation**

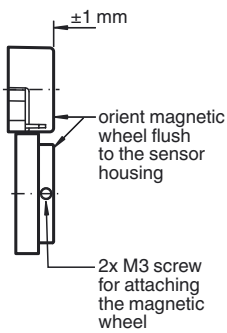

**Shaft displacement**

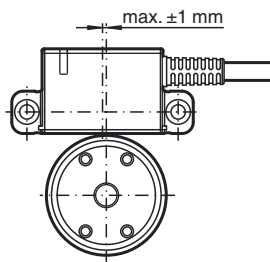

**Angular displacement**

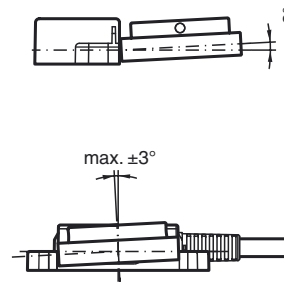

Release date: 2014-12-19 10:28 Date of issue: 2014-12-19 t42651\_eng.xml

**Electrical connection**

Signal	Cable, 8-core
GND	White
+U <sub>b</sub>	Brown
A	Green
B	Grey
$\bar{A}$	Yellow
$\bar{B}$	Pink
0	Blue
$\bar{0}$	Red
Screen	-

**Signal outputs**

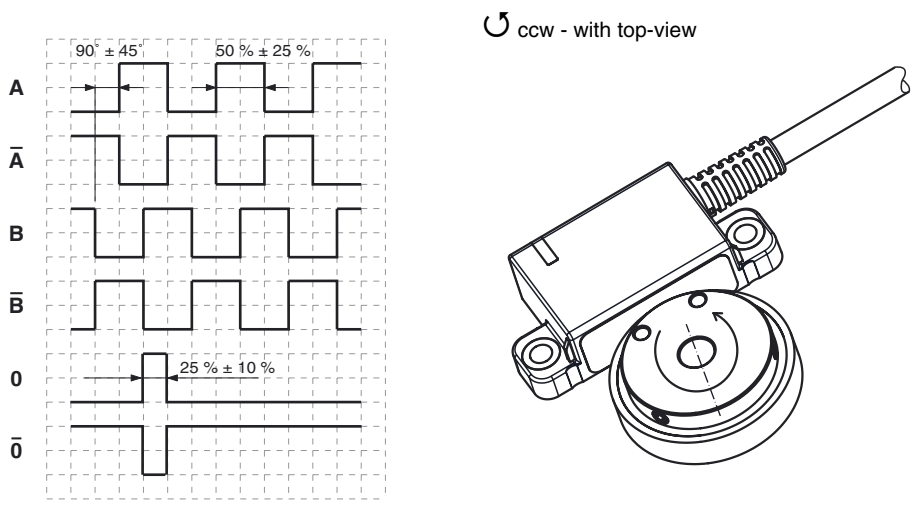

**LED-Indicators**

LED status	Description
Green On	Sensor self test and magnetic wheel verification successfully completed.
Green Flashing	Sensor waiting to complete single magnetic revolution for code wheel verification process.
Red Flashing	Warning Alignment or wheel velocity detected as out of specified limits. Possible cause: improper alignment (large sensor-wheel gap, magnetic wheel misalignment, ... )
Red On	Error Possible reason: <ul style="list-style-type: none"> <li>• Supply voltage drop</li> <li>• Magnetic wheel not detectable (e. g. too large gap)</li> <li>• Broken magnetic wheel</li> </ul>

Release date: 2014-12-19 10:28 Date of issue: 2014-12-19 f42651\_eng.xml

Order code

M N I 4 0 N - K 2 6 N -

Pulse count see below

Temperature

N normal

Output type

- 1 10 V ... 30 V, push-pull
- 6 5 V, RS 422

Signal output

6 A + B + 0 and  $\bar{A}$  +  $\bar{B}$  +  $\bar{0}$

Connection type

K2 Cable, 2m

Magnetic wheel specifications

<b>01</b>	50 Poles, Ø31.7 mm (1.25") Pulse counts: 50, 100, 200, 500, 800, 1000, 1250, 1600, 2400, 2500, 5000
<b>A1</b>	64 Poles, Ø40.6 mm Pulse counts: 64, 128, 512, 1024, 1600, 2048, 3072, 3200
<b>E1</b>	72 Poles, Ø46 mm Pulse counts: 360, 1800, 3600, 7200

Bore hole of magnetic wheel

- 0S Ø6 mm
- 0A Ø10 mm
- 0B Ø12 mm
- 0T Ø15 mm
- 0F Ø20 mm
- 0G Ø24 mm
- 0H Ø25 mm
- 0I Ø30 mm

Housing material

N Plastic

Version

MNI Magnetic principle, Non-contact, Incremental