



## Model Number

CSM36M-\*\*\*\*\*

## Features

- **Very small housing**
- **High climatic resistance**
- **Up to 25 Bit multiturn**
- **Galvanically isolated CAN interface**
- **Surge and reverse polarity protection**
- **2 limit switches**
- **8 cam switches**

## Description

This absolute rotary encoder provides a position value corresponding to the shaft position on its integrated CAN bus interface. The rugged miniature series Cxx36M encoders are based on magnetic sampling.

The integrated CAN-bus interface supports all CANopen functions. Thus the following modes can be programmed to either enabled or disabled:

- Polled Mode
- Cyclic Mode
- Sync Mode

## Technical data

### General specifications

Detection type	magnetic sampling
Device type	Multiturn absolute encoder

### Electrical specifications

Operating voltage $U_B$	10 ... 30 V DC
Power consumption $P_0$	approx. 2 W
Output code	binary code
Code course (counting direction)	adjustable

### Interface

Interface type	CANopen
Resolution	
Single turn	up to 13 Bit ( hysteresis: 0.1 ° )
Multiturn	up to 12 Bit
Overall resolution	up to 25 Bit
Transfer rate	max. 1 MBit/s
Standard conformity	DSP 406, CLASS 2

### Connection

Connector	M12 connector, 5 pin
Cable	Ø6 mm, 4 x 2 x 0.14 mm <sup>2</sup> , 1 m

### Standard conformity

Degree of protection	acc. DIN EN 60529
Connection side	cable models: IP54 connector models: IP65
Shaft side	IP54
Climatic testing	DIN EN 60068-2-3 , 98 % , no moisture condensation
Emitted interference	EN 61000-6-4:2007
Noise immunity	EN 61000-6-2:2005
Shock resistance	DIN EN 60068-2-27, 100 g, 6 ms
Vibration resistance	DIN EN 60068-2-6, 10 g, 10 ... 1000 Hz

### Ambient conditions

Operating temperature	cable, flexing: -5 ... 70 °C (-23 ... 158 °F), cable, fixed: -30 ... 70 °C (-22 ... 158 °F) connector models: -30 ... 85 °C (-22 ... 185 °F)
Storage temperature	cable models: -30 ... 70 °C (-22 ... 158 °F) connector models: -30 ... 85 °C (-22 ... 185 °F)
Relative humidity	98 % , no moisture condensation

### Mechanical specifications

Material	
Housing	nickel-plated steel
Flange	aluminum
Shaft	Stainless steel
Mass	approx. 150 g , with cable
Rotational speed	max. 12000 min <sup>-1</sup>
Moment of inertia	30 gcm <sup>2</sup>
Starting torque	< 3 Ncm
Shaft load	
Axial	40 N
Radial	110 N

Dimensions

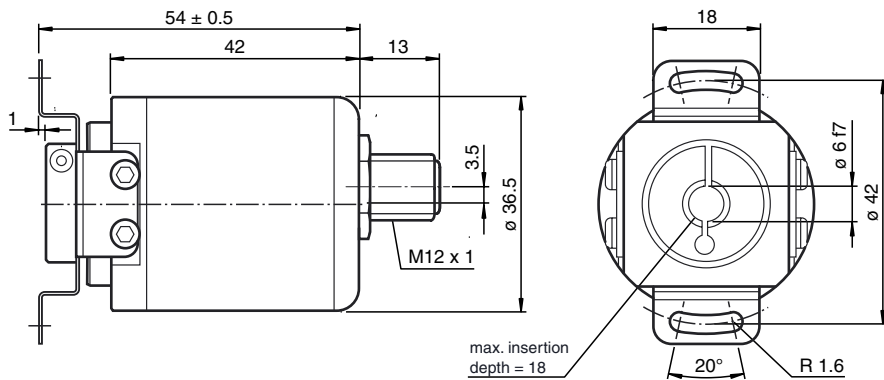
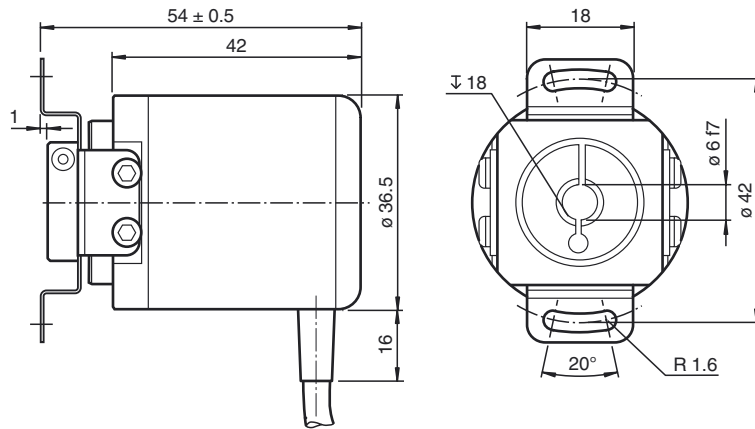
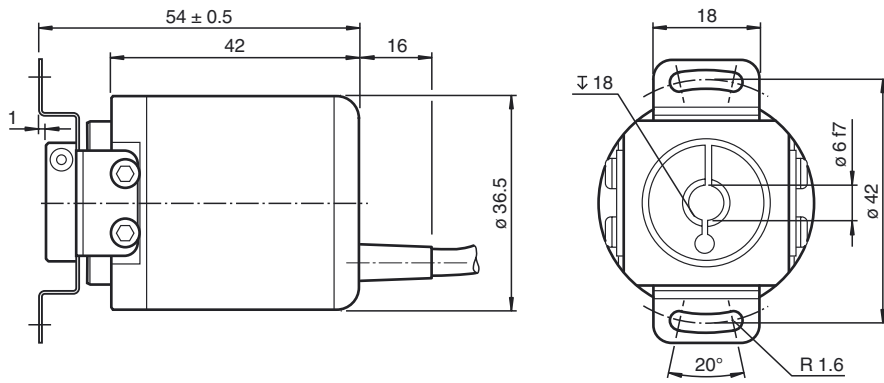

Recessed hollow shaft

Release date: 2014-04-15 10:07 Date of issue: 2014-04-15 142978\_eng.xml

### Electrical connection

Signal	Wire end	Connector
CAN GND	green	1
V <sub>S</sub> (10 ... 30 V DC)	red	2
GND	yellow	3
CAN-High	white	4
CAN-Low	brown	5
Shielding	Shielding	Housing
Pinout		

**Programmable CAN operating modes**

Mode	Explanation
Polled mode	The connected host requests the current actual position value via a remote transmission request telegram. The absolute encoder reads in the current position, calculates all parameters that have been set and sends back the process actual value through the same CAN identifier.
Cyclic mode	The absolute encoder sends the current actual process value cyclically, without being prompted by the host. The cycle time can be programmed in milliseconds for values between 1 ms and 65536 ms.
Sync mode	After the sync telegram has been received by the host, the absolute encoder sends the current actual process value. If multiple nodes should respond to the sync telegram, the individual nodes report one after the other according to their CAN identifier. There is no programming of an offset time. The sync counter can be programmed so that the rotary encoder does not transmit until after a defined number of sync telegrams.

**Programmable rotary encoder parameters**

Parameter	Explanation
Operating parameter	The direction of rotation (complement) can be specified by parameter as the operating parameter. This parameter determines the direction of rotation in which the output code will ascend or descend.
Resolution per revolution	The "Resolution" parameter is used to program the rotary encoder so that a desired number of steps can be implemented in reference to one revolution.
Preset value	The preset value is the desired position value that must be achieved for a specific physical setting of the axis. The preset value parameter is used to set the actual position value to the desired actual process value.
Min. and max. limit switch	A total of two positions can be programmed. The absolute encoder sets one bit to high state in the 32 Bit actual process value if a value falls outside the range between these two positions.
Cam	8 freely programmable cams can be set within the overall resolution. This produces the functionality of a mechanical cam shifting mechanism.

**Order code**



- Number of bits singleturn**
  - 12 4096 (standard)
  - 13 8192 (max.)
- Number of bits multiturn**
  - 12 **4096 (standard)**
- Temperature**
  - N Normal
- Output code**
  - B Binary
- Option**
  - 0 None
- Exit position**
  - A Axial
  - R Radial (only cable version)
- Connection type**
  - K1 Cable Ø6 mm, 4 x 2 x 0.14 mm², 1 m
  - BD Connector, M12 x 1, 5 pin
- Shaft dimension/flange version**
  - F4A Hollow shaft Ø6 mm
- Sampling principle**
  - M magnetic
- Principle of operation**
  - M Multiturn
- Shaft version**
  - S Recessed hollow shaft
- Data format**
  - C CANopen

Release date: 2014-04-15 10:07 Date of issue: 2014-04-15 142978\_eng.xml