



Desigo™ RXC

Extension module for the control of blinds

RXC41.1
RXC41.5

Extension to the RXC30 / RXC31 / RXC38 room controller

The RXC41 extension module is used in conjunction with an RXC30 / RXC31 / RXC38 room controller for the control of blinds in individual rooms.

- Control of two electric motors for blinds
- Application software downloadable into RXC30 / RXC31/ RXC38 basic module
- Plug-in connection to RXC30 / RXC31 / RXC38 basic module for power supply and data
- Volt-free relay contacts for motor control

Application

The RXC41 module acts as an I/O extension to the basic RXC30 / RXC31 / RXC38 room controller. The input/output configuration is optimized for the control of two electric motors to operate blinds.

The RXC30 / RXC31 / RXC38 basic room controller and the RXC41 extension module are connected electrically and (when the terminal covers are fitted) mechanically to form a single unit. If required, this can be supplemented with a second RXC41 module or an additional RXC40 extension module for the control of lighting.

For operation, either conventional momentary-contact switches, or integrated operating units with a bus connection may be used.

The application software for the complete unit, comprising the basic module and the extension module(es) is downloaded into the RXC30 / RXC31 / RXC38 room controller. Where the RXC30 / RXC31 / RXC38 controller is loaded with basic application 00030 / 00031, test functions for the RXC41 extension module are also available.

Functions

The functioning of the RXC41 extension module is defined by the application software downloaded into the RXC30 / RXC31 / RXC38 room controller.

For a detailed description of functions, refer to the Desigo RXC applications library (V1: CA2A3810, V2: CA110300).

Types

| Product No. | Stock number | Designation |
|-------------|--------------|--|
| RXC41.5 | S55373-C120 | Extension module for control of blinds |
| RXZ40.1 | | Accessories: Terminal covers |

Ordering

When ordering, please specify the quantity, product name and type code. The RXZ40.1 terminal covers are supplied in packs of 10 pairs and must be ordered separately.

Example:

| | | |
|-----------|---|----------------|
| 30 | Extension module for the control of blinds | RXC41.5 |
| 30 | Pairs of terminal covers | RXZ40.1 |

Compatibility

The RXC41 extension module is always used in conjunction with an RC30.1, RXC31 or RXC38 room controller (data sheet 3840 / 3844 / 3841). If required, a second RXC41, or an RXC40 extension module for lighting control (data sheet 3842) can be added. Possible combinations and the associated applications are described in the Desigo RXC applications library (V1: CA2A3810, V2: CA110300).

For operation, either conventional momentary-contact switches or the flexible room units, QAX50.1 or QAX51.1 may be used.

Note

If different types of extension module are used, they must be arranged in the following order: RXC30 / RXC31 / RXC38 → RXC40 → RXC41

Mechanical design

The RXC41 extension module consists of a housing base, a housing cover and the printed circuit board with connection terminals. The module also has a ribbon cable and connector for connection to the RXC30 / RXC31 / RXC38 basic controller (or the preceding extension module) and a connector base into which a further extension module may be plugged.

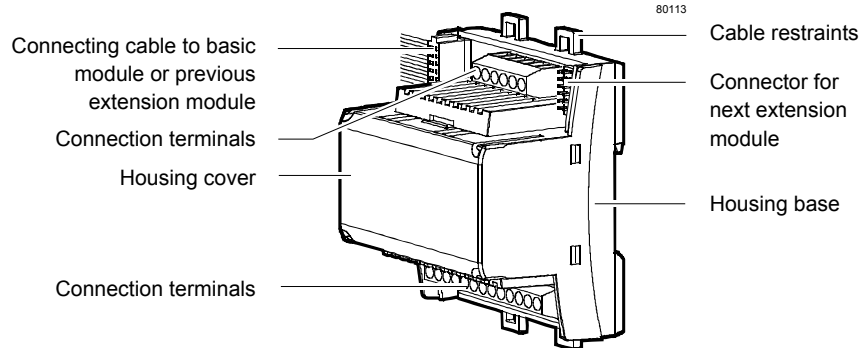

Terminal covers

Terminal covers (RXZ40.1) are available as an option, to protect the connection terminals from physical contact and dirt. These covers also provide strain relief for the cable to the RXC30 / RXC31 / RXC38 controller. When fitting the terminal covers, make sure that they lock into position correctly.

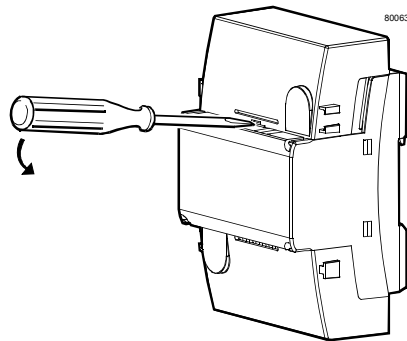

Removing the terminal cover

Label

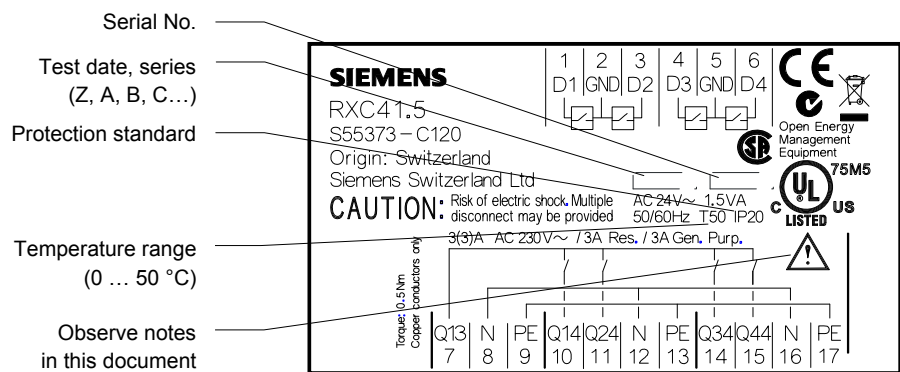

3843Z01_02

Connection terminals

All connection terminals are detachable plug-in terminals. To avoid incorrect wiring, terminals which can be connected to AC 230 V (relay outputs) are physically separate from the other terminals. They are arranged so that in normal circumstances, all incoming and outgoing cables can be connected without crossing.



Note!

Cable restraints on the housing base *must* be used for the connections to terminals 7 ... 17 (AC 230 V).
The conductors must be secured with cable ties (see diagram).

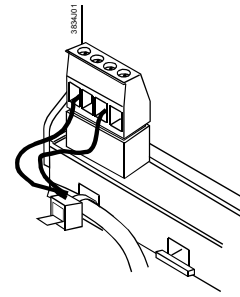

Warning!

Ensure that the power is off before inserting or removing plug-in terminals connected to a mains voltage.

Communication

The RXC41 extension module communicates via a serial bus connection (the PE bus) with the RXC30 / RXC31 / RXC38 controller. The PE bus connections are looped through the module to the connection socket for the next extension module.

There is no direct connection to the LONWORKS® bus.

Disposal



The devices are classified as waste electronic equipment in terms of the European Directive 2002/96/EC (WEEE) and should not be disposed of as unsorted municipal waste. The relevant national legal rules are to be adhered to.
Regarding disposal, use the systems setup for collecting electronic waste. Observe all local and applicable laws.

Engineering notes

The RXC41 can be used only in conjunction with an RXC30 / RXC31 / RXC38 basic module (and possible additional extension modules). The plug-in connection between the basic module and the extension modules incorporates both the communications and the power supply. The power supply is limited to a maximum of two extension modules.

Signal inputs

The cables for signal inputs D1 ... D4 (SELV / PELV) must be routed separately from the AC230 V cables and must comply with SELV / PELV requirements. The low voltage and mains voltage must not be routed in the same cable.



Note!

AC 250 V volt-free relay outputs

Only volt-free pulsed momentary-contact switches may be connected to the signal inputs.

Cable sizing for motorized blinds depends on the connected load and the local installation regulations. Neutral and protective conductors are looped on the controller so that there is no need for external terminals. The cables must be secured with cable restraints.



Note!

The maximum load per module (for both motors together) is restricted to 3A.

An interlock makes outputs Q14 / Q 24 and Q34 / Q44 mutually exclusive. To protect the cables, the circuits must be fused in accordance with local regulations.

Mounting

The RXC41 extension module is mounted together with the RXC30 / RXC31 / RXC38 basic module and any additional extension modules on a DIN rail (type EN50022-35x7.5).

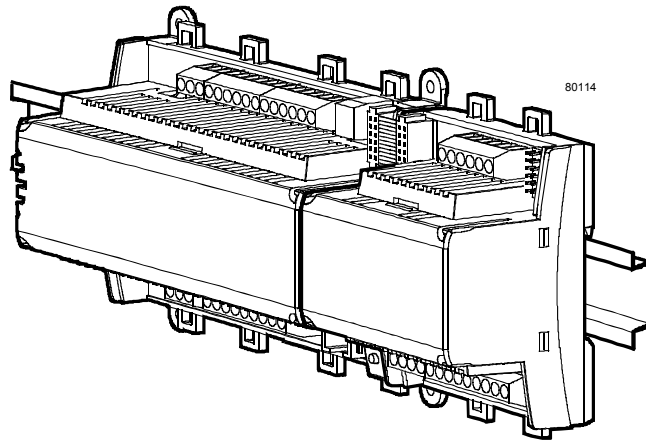

When mounting, note the following:

- The controller should not be freely accessible after mounting
- Ensure adequate air circulation to dissipate heat generated during operation.
- Easy access is required for service personnel
- Local installation regulations must be observed.

The mounting instructions are printed on the controller packaging.

Commissioning

The notes in the technical documentation for the RXC30 / RXC31 / RXC38 room controller (data sheet 3840, 3844) apply equally to a combination comprising the RXC30 / RXC31 and the RXC41 extension module.



Note!

- **The module is not protected against accidental connection to AC 230 V on the SELV / PELV side.**
- **Mains AC 230 V for the relays must be disconnected before plugging and unplugging the terminal blocks (danger of electric shock!)**

Technical data

| | | |
|--|--|---|
| Power supply | The module receives its power from the RXC30 / RXC31 / RXC38 basic controller Power consumption (from basic controller) | SELV / PELV AC 24 V Max. 1.5 VA |
| Inputs Signal inputs D1 ... D4 (for volt-free momentary contact switches) | Quantity Contact voltage Contact current Contact transfer resistance Contact insulation resistance | 4 DC 33 V DC 8 mA Max. 100 Ω Min. 50 kΩ |
| Outputs △ Relay outputs Q14 ... Q44 | Quantity Relay type Contact rating with AC voltage Switching voltage Nominal current, resistive / inductive Making current 200 ms half-time Switching current at AC 29 V Contact rating with DC voltage Switching voltage Switching current at DC 5 V Switching capacity Inductive load L/R | 2 x 2 Single pole Max. AC 250 V, min. AC 19 V Max. AC 3A Max. 20 A Min. AC 10 mA Max. DC 250 V, min. DC 5 V Min. DC 100 mA Max. 20 W Max. 7 ms |
| Interface to RXC30 / RXC31 / RXC38 basic module and other extension modules | Interface type | Serial bus (for power supply and data) |
| Cable connections | Plug-in terminal blocks Solid conductors Stranded conductors without connector sleeves Stranded conductors with connector sleeves (DIN 46228/1) Max. tightening torque Connecting cable to basic module Single cable lengths Signal inputs D1... D4 Relay outputs Q14 ... Q44 | Rising cage terminals 1 x 0.2 ... 2.5mm ² or 2 x 0.2 ... 1.0 mm ² 1 x 0.2 ... 2.5mm ² or 2 x 0.2 ... 1.5 mm ² 1 x 0.25 ... 2.5mm ² or 2 x 0.25 ... 1.0 mm ² 0.6 Nm 10-core ribbon cable See also installation guide, CA110334 Max. 100 m with diameters ≥ 0.6 mm Depends on load and local regulations |
| Housing protection standard | Protection standard to EN 60529 | IP30 with terminal cover fitted and wall mounted without DIN rail All other mounting arrangements: IP20 |
| Protection class | Suitable for use in systems with protection class I or II | |
| Ambient conditions | Operation Temperature Humidity Transport Temperature Humidity | Class 3K5 to IEC 60721-3-3 0 ... 50 °C < 85 %rh Class 2K3 to IEC 60721-3-2 - 25 ... 65 °C < 95 %rh |
| Standards and directives | Product safety Automatic electronic controls for household and similar use Electromagnetic compatibility Immunity (domestic) Emissions (domestic) CE compliance Meets requirements of EMC Directive Low Voltage Directive RoHS compliance UL compliance | EN 60730-1 EN 60730-1 EN 60730-1 2004/108/EC 2006/95/EC 2011/65/EU UL916 |



C-Tick conformity (EMC)

AS/NZS 61000-6-3

Environmental compatibility

The product environmental declaration CA2E3842 contains data on RoHS compliance, materials composition, packaging, environmental benefit, disposal

ISO 14001 (Environment)
ISO 9001 (Quality)

Dimensions

See dimension diagrams

Width in DIN modular spacing units 4.5

Weight

Excluding packaging 0.16 kg

Connection terminals

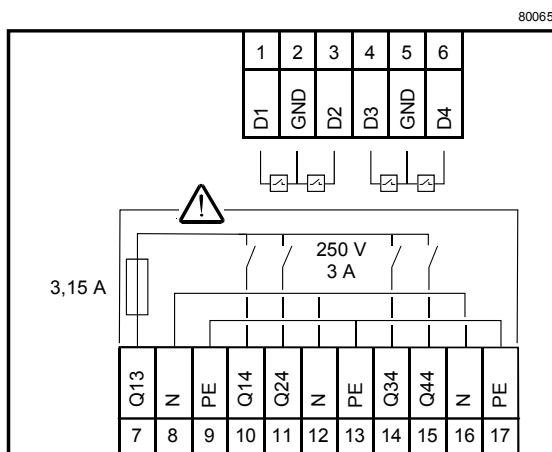

Signal input for volt-free momentary-contact switches

| | | |
|-----|---|---------------|
| D1 | 1 | Signal input |
| GND | 2 | Signal ground |
| D2 | 3 | Signal input |
| D3 | 4 | Signal input |
| GND | 5 | Signal ground |
| D4 | 6 | Signal input |

Relay outputs

| | | |
|-----|----|----------------------------------|
| Q13 | 7 | Common contact for Q14 ... Q44 |
| N | 8 | Neutral conductor, max. AC 250 V |
| PE | 9 | Protective earth conductor |
| Q14 | 10 | N/O contact AC max. 250 V, 3 A |
| Q24 | 11 | N/O contact AC max. 250 V, 3 A |
| N | 12 | Neutral conductor, max. AC 250 V |
| PE | 13 | Protective earth conductor |
| Q34 | 14 | N/O contact AC max. 250 V, 3 A |
| Q44 | 15 | N/O contact AC max. 250 V, 3 A |
| N | 16 | Neutral conductor, max. AC 250 V |
| PE | 17 | Protective earth conductor |



Note!

- **Observe the technical data for the relay outputs: max. AC 250 V, 3 A**
- **Local installation regulations must be observed.**

Connector for extension modules

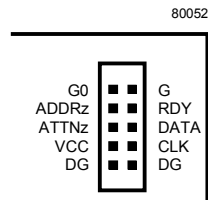

| | | | |
|-------|--------------------|------|--------------------|
| G0 | Ground | G | AC 24 V |
| ADDRz | Module address | RDY | Handshake |
| ATTNz | Handshake | DATA | Data |
| VCC | DC 5 V | CLK | Clock |
| DG | Electronics ground | DG | Electronics ground |

Connection diagrams

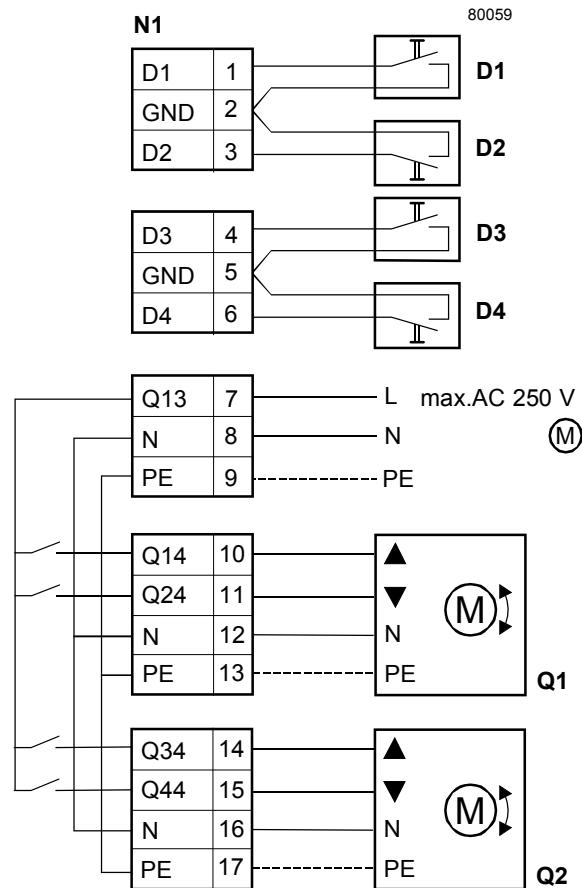

N1 RXC41
D1 ... D4 Volt-free momentary contact switches
Q1, Q2 Electric motors for blinds



Note!

Parallel connection of blind motors to one output must be avoided, as this can damage the motors.

The maximum load per module (for both motors together) is restricted to 3A.

Dimensions

All dimensions in mm

Without terminal covers

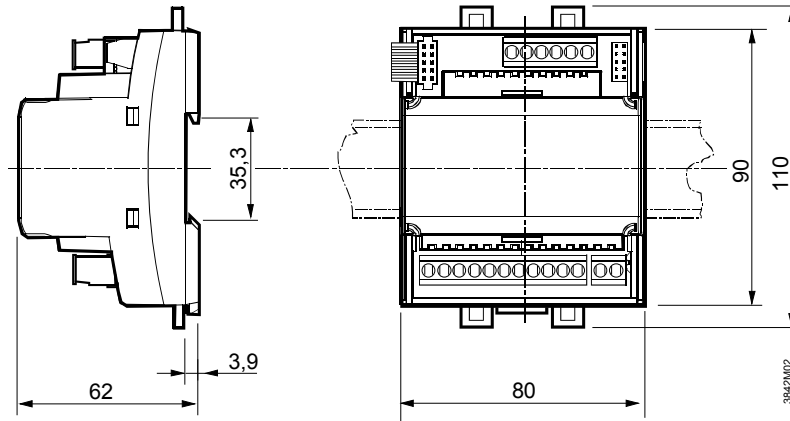

With terminal covers

