

DESIGO™ RX

Service terminal**RXT20.1**

-
- Hand-held service terminal with built-in connecting cable
 - Controller and room unit status display
 - Remote operation of DESIGO RXB and RXC room controller service pins
 - **NOT SUITABLE FOR RXB VERSION 2.36 AND HIGHER**
 - Error message display
 - Room temperature display, operating mode and temperature setpoint adjustment
 - PPS2 interface to controller
 - Socket for commissioning and service too
-

Use

The RXT20.1 service terminal is used for simple diagnostics of room controllers and room units, and for remote operation of the DESIGO RXB and RXC controller service pins. The built-in connecting cable of the service terminal is plugged directly into the roomcontroller to be interrogated, or into the room unit of the controller concerned.

The service terminal displays the status of the controller and room unit, the “wink” function, error messages or additional information of the room unit.

The service pin of the connected DESIGO RXB / RXC controller can be operated remotely with the function keys on the service terminal. This function is especially useful for addressing controllers installed in concealed locations.

The service terminal also incorporates a RJ45 socket for the bus

- RXC: for RXT10 commissioning and service tool (LONWORKS® bus connection)
- RXB: for KNX / EIB bus connection (not for Version 2.36 and higher).

Ordering

When placing an order, please specify the quantity, product name and type code.

Example:

1 Service terminal RXT20.1

Mechanical design

Essentially, the service terminal consists of the housing, the base plate and the cable for connection to the controller or room unit. The housing and the base plate are connected by a snap-fitting mechanism.

The housing accommodates a printed circuit board, the function keys, LCD and a socket for the commissioning and service tool.

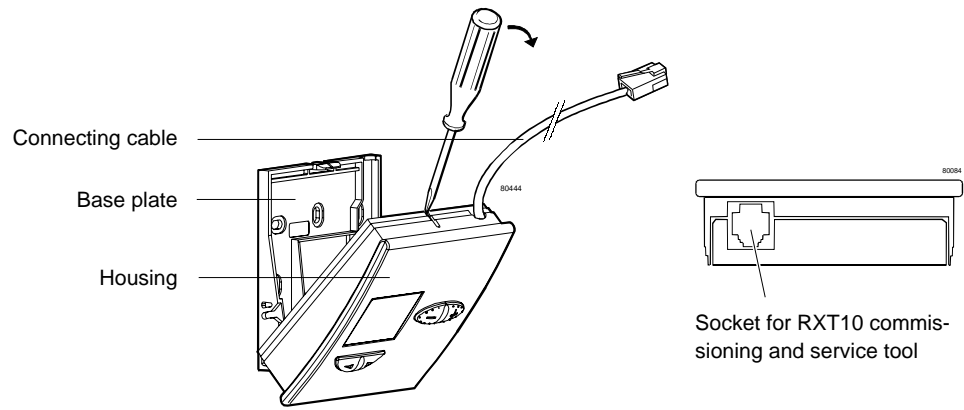

Elements for operation and display

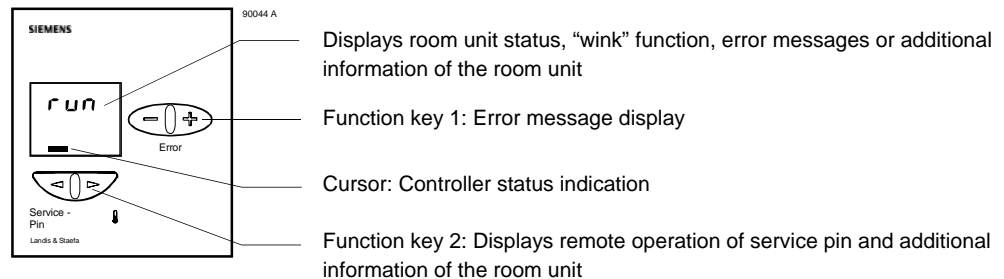

Function key 1:

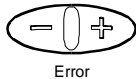

Action	Description
Press + or – key	Press once to display any existing error messages.
 Error	The error with the highest priority is displayed for 5 s. For error codes see "LCD display"



Function key 2:

Action	Description
Press left key	The service pin is used to address the controllers when commissioning the system. – RXC: refer to the RXT10 user manual, document CA2110338 – RXB: refer to the ETS manual.
 Service pin	This function of the service terminal is especially useful for addressing controllers in concealed locations where direct access to the service pin is difficult. For this purpose, the service terminal is connected to the room unit of the controller concerned. Press this key on the left side for at least 1.5 s for remote operation of the service pin of the connected DESIGO RXB / RXC controller. While service-pin operation is in progress, the LCD display is blank. The controller, room unit and service terminal will then restart (ready for operation after approx. 3 – 5 minutes*) * Varies according to the DESIGO RX application
Press right key	1 st key press Room temperature display in °C 2 nd key press Room temperature display in °F 3 rd key press Setpoint adjustment display in °C 4 th key press Setpoint adjustment display in °F 5 th key press Return to original display (e.g. "run")

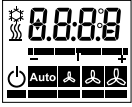

LCD display
Response at start-up

If the service terminal is connected to a DESIGO RXB / RXC controller, the start-up routine is as follows:

Step	Display	Description
1		All segments activated for approximately 5 s.
2		Cursor fields may be activated for max. 10 s.* (approx. 3 – 5 minutes * on controller power up, e.g. after operation of service pin) * Varies according to the DESIGO RX application
3		Controller ready for operation ("run" and cycling cursor)

Display	Description
	<i>Normal operation between controller and room unit</i> <ul style="list-style-type: none"> • Display reads "run" The room unit with the set address (see Address switch) communicates with the controller. The "run" display can be overwritten by other displays (see Additional information). • Cycling cursor, 1 s pulse The controller communicates (or tries to communicate).
	<i>no communication, or controller not ready</i> <ul style="list-style-type: none"> • Static display in all cursor fields There is no room unit connected or the controller is not ready for operation, but the power supply is working (controller in start-up phase, or no application loaded, or controller not configured).
	<i>Faulty controller:</i> <ul style="list-style-type: none"> • No display The power supply is not connected or the controller is faulty.

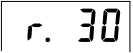
Additional information

Display	Description
	<i>Wink command</i> <ul style="list-style-type: none"> • Controller type displayed for 64 s (e.g. RXC30.1: "r.30" or RXB21.1: "r.21") Press the right key (Function key 2) to switch back to the original display before expiry of the 64 s. The display of the wink command takes priority over all other display options on the service terminal. The wink command can be used during commissioning to identify the currently addressed controller. <ul style="list-style-type: none"> – RxC: see RXT10 user manual, document CA110338 – RxB: see ETS user manual
	<i>Room temperature, operation mode</i> <ul style="list-style-type: none"> • Room temperature in °C or °F (see "Function key 2") The displayed operation mode (Stand-by, Auto, fan speed) comes from the room unit. The same applies to the displayed room temperature, there is no temperature sensor in the service terminal itself.

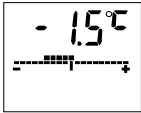
	<p><i>Temperature setpoint</i></p> <ul style="list-style-type: none"> Temperature setpoint in °C or °F (see "Function key 2") <p>The displayed temperature setpoint comes from the room unit.</p>
--	--

Static error messages

Display	Description
	The address of the service terminal has not been set correctly (see "Hex switch").

Dynamic error messages

Dynamic error messages are displayed for 5 s when they occur. The error message remains in memory while the error persists. The message can be re-displayed for 5 s using Function key 1. If there is more than one error, the error with the highest priority will be displayed. The table below shows the error messages in order of priority.

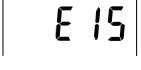
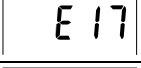
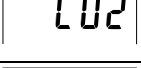
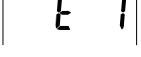
Display	Description
	There has not yet been any communication between the room unit and the controller (e.g. during the controller power-up phase)
	The controller does not recognise the room unit type.
	C: Communication between controller and room unit is interrupted. 02: Firmware version of the service terminal (e.g. Version 2.0)
	Error (open circuit or short circuit) affecting the potentiometer or temperature sensor of the connected room unit.

Room temperature

Display	Description
	Room temperature in °C or °F (see "Function key 2") The displayed room temperature is the temperature measured by the room unit; there is no temperature sensor in the service terminal itself.

Address switch

The service terminal must have the same PPS2 address as the room unit (address 1 ... 12) in order to display any of the information described above. The QAX3... room units are all factory-set to Address 1. The service terminal is also factory-set to Address 1.

The address can be changed if necessary:

- Service terminal: hex switch on the back of the housing; remove base plate for access
- Room unit: Address plugs.

If an invalid address is set (e.g. "0"), the error message "E16" will be displayed.

Note

If the address of the service terminal and the room unit are not the same, or if several devices are communicating, the "normal operation" display will show 12 extra points (one for each possible address). The points that stand for actively communicating devices are flashing.

Disposal



The device includes electrical and electronic components and must not be disposed of as domestic waste.

Current local legislation must be observed.

Technical data

Power supply	Operating voltage The service terminal receives its supply from the connected controller via the PPS2 interface (SELV low voltage in accordance with HD 384) Power consumption (controller)	DC 12 ... 15 V Max. 0.10 VA
Function data	Display Type Functions displayed Function keys	LCD – Controller and room unit status – Wink function – Additional information of the room unit – Function key 1: Error message display – Function key 2: Remote operation of service pin and display of additional information of the room unit
Interfaces	Interface between controller and service terminal Baud rate	PPS2 (point-to-point interface, Version 2) 4.8 kBit/s
Cable connections	Cable for connection to controller or room unit Cable length	Built-in Approx. 15 cm
Housing protection standard	Protection standard to EN 60529	IP 30
Protection class	Insulation protection class	III
Environmental conditions	Operation Climatic conditions Temperature Humidity Mechanical conditions Transport Climatic conditions Temperature Humidity Mechanical conditions	IEC 721 Class 3K5 0 ... 50 °C < 85 %rh Class 3M1 IEC 721 Class 2K3 – 25 ... 70 °C < 95 %rh Class 2M2
Industry standards	Electromagnetic compatibility Interference immunity Emitted interference Meets the requirements for CE marking: EMC Directive	EN 61000-6-2 EN 61000-6-3 89/336/EWG
Dimensions	see “Dimensions”	
Colour	Housing cover Operator controls	NCS 0502-Y14R RAL 7035
Weight	Excluding packaging	0.13 kg

Internal diagram

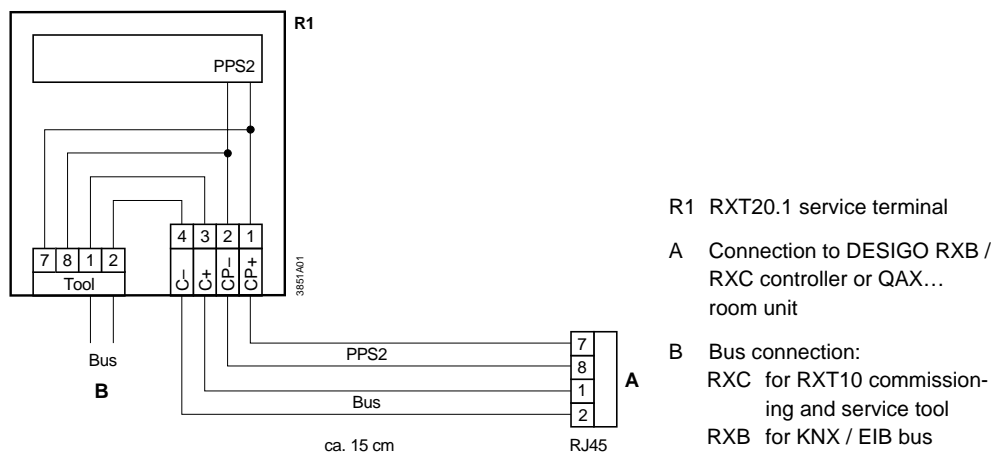

Pin layout of RJ45 connector

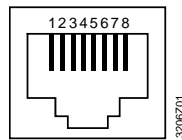

- 1 LONWORKS® -Bus (DESIGO RXC): CLA; EIB-Bus (DESIGO RCB): CE+
- 2 LONWORKS® -Bus (DESIGO RXC): CLB; EIB-Bus (DESIGO RCB): CE-
- 3 Not used
- 4 Not used
- 5 Not used
- 6 Not used
- 7 CP+ PPS2 data
- 8 CP- PPS2 data

The same pin layout applies to the tool socket.

Connection diagram

The built-in connecting cable with an RJ45 connector is used to connect the service terminal to the tool socket of a DESIGO RXB / RXC controller, or to a QAX... room unit. The service terminal communicates with the controller via the PPS2 interface. Additionally, the bus is looped through the service terminal. RXC: this enables a PC for the RXT10 service tool to be connected to the tool socket of the service terminal.

Caution:

For correct operation of the service terminal, there must always be a room unit connected to the controller. PPS2 communication is not possible without a room unit.

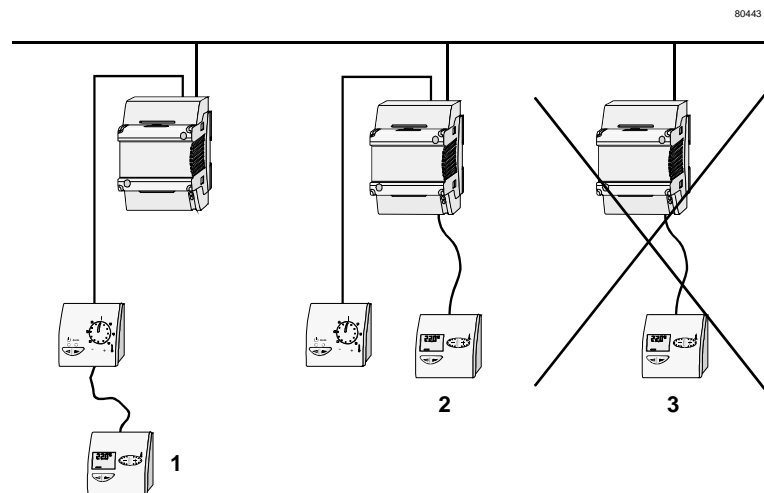

Options for connecting the RXT20.1 service terminal:

- 1 To QAX... room unit
- 2 To RXC... room controller
- 3 **Not possible without QAX... !**

Dimensions

All dimensions in mm

