

DESIGO™

## Current valve

## SEA45.1

for AC 24 V pulse/pause control  
of electrical loads up to 30 kW

---

### Use

The current valve is used for the control of electric heating elements in heating, ventilation and air conditioning plant, e.g.:

- Electric heating coils
- Fan coil units
- Induction units
- Electric radiators
- Electric underfloor and ceiling heating systems
- Reheaters in fan coil units and supply air ducts
- Convactor heaters and panel heating

The current valves are designed to switch the following resistive loads:

Load voltage	Minimum switching capacity <sup>1)</sup>	Maximum switching capacity <sup>2)</sup>
1 x AC 230 V	0.04 kW	5.75 kW (= 25A)
1 x AC 400 V	0.06 kW	10.0 kW (= 25A)

1) Used for sizing the load; has nothing to do with controllability

2) The maximum switching capacity applies to single-phase applications.

For higher switching capacities, see connection diagrams 1...4.

## Ordering

---

When ordering, please state the quantity, product name and type code, e.g.

**10     Current valves     Type SEA45.1**

## Compatibility

---

The current valves can be controlled by any device capable of delivering one of the following control signals:

- AC 24 V pulse/pause control signal
- Proportional DC 0...10 V control signal <sup>1)</sup>
- On/off control signal, DC 0 or 10 V<sup>1)</sup>

1) Requires conversion into an AC 24 V pulse/pause control signal.  
The SEM61.4 signal converter is available for this purpose (see data sheet 5102).

## Technical design

---

The current valve is a solid-state power switch (thyristor). It regulates the amount of electrical energy supplied to the connected heating element.

The output power is determined by the AC 24 V pulse/pause control signal. It is switched at the zero-voltage crossing point, in order to avoid the introduction of mains interference.

The control signal and power signal are electrically isolated (by opto-coupler), enabling the controller and the current valve to be powered by different phases.

## Mechanical design

---

The current valve consists of a black aluminum heat sink (with four channels for heat dissipation) suitable for mounting on a DIN rail. A plastic housing accommodating the electronic circuit and connection terminals is snap-mounted onto this base.

The underside of the baseplate has a snap-on facility for fixing the current valve to a DIN rail.

The printed circuit board is not encapsulated. In fact, it is actually ventilated by thermal convection through the unused terminal cavities.

The front plate of the electronics housing accommodates the type label and an electrical diagram to assist with wiring. An operating diagram is printed on the side of the electronics housing, showing the maximum permissible load current as a function of the ambient temperature.

LED display

An LED located below terminal Y1 (above the relay symbol) lights up when the control signal is "ON".

## Engineering

---

- The equipment must be installed in such a way as to ensure that the permissible ambient conditions are maintained. Ensure adequate ventilation especially when installing current valves in control panels.
- The maximum permissible load current (effective value) is dependent on the ambient temperature. **At temperatures above 40°C the load current must be reduced (see diagram):**

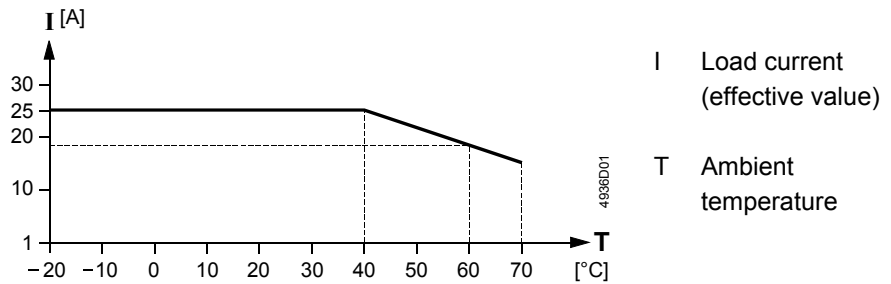

**Warning:**

- In control panels or fan coil units where the ambient temperature during operation exceeds 40 °C, a fan must be provided for bottom-to-top ventilation.
- The graph below shows the quantity of heat to be dissipated as a function of the load current. It serves as a basis for calculating the cooling requirements.**

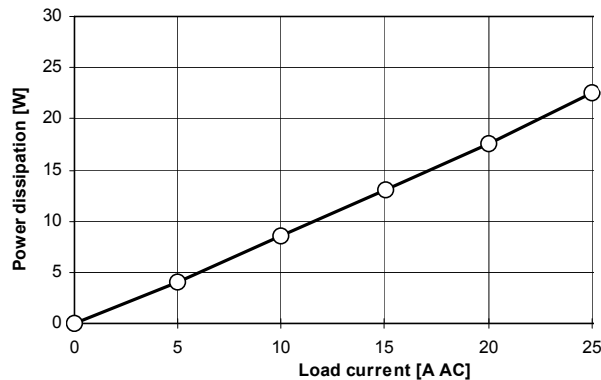

- Mains voltage tolerances must be included in load calculations. The maximum allowable load current of 25 A must not be exceeded.
- The rated current of the connected heating element must not be lower than the minimum load current of the current valve (see "Technical data").
- The load input (terminal L) may only be fused with fast-acting fuses: max. 25 A ( $I^2t < 6600 \text{ A}^2\text{s}$ ).
- The system voltage and load voltage may have different phases.
- At least one thermal cut-out must be provided for protection of a heater battery. This must not be interlocked with the current valve on the control side: instead, it should cut off the power supply to the heating element, either directly or via a switching contactor.
- Heater batteries must not be fitted with short-circuit high-temperature cut-outs.
- The heat sink may be earthed.
- Under normal operation, the heat sink may become very hot (approx. 90°C). Personnel must be warned to avoid touching the heat sink during or directly after operation. Maintained a safe distance from cable ducts.
- The following minimum clearance between the current valve and other devices must be maintained:
  - 10 mm on either side of the current valve
  - 100 mm above the current valve
  - 20 mm below the current valve

**Warning:**

## Mounting and installation

- Mounting location: on wall or in control panel, with forced ventilation precautions where necessary.
- Mounting method: snap-mounting on DIN rail
- Local electrical installation regulations must be observed.
- Mounting instructions are supplied with the current valve.

### Warning:

- **Always install current valves so that the cooling fins are vertical.**
- **Forced ventilation of the control panel must be from bottom to top only, to support natural convection through the heat-sink cooling channels.**
- **Forced ventilation must not be directed horizontally at the devices, as this can impede natural convection through the cooling channels.**
- **Current valves must not be installed one above the other.**

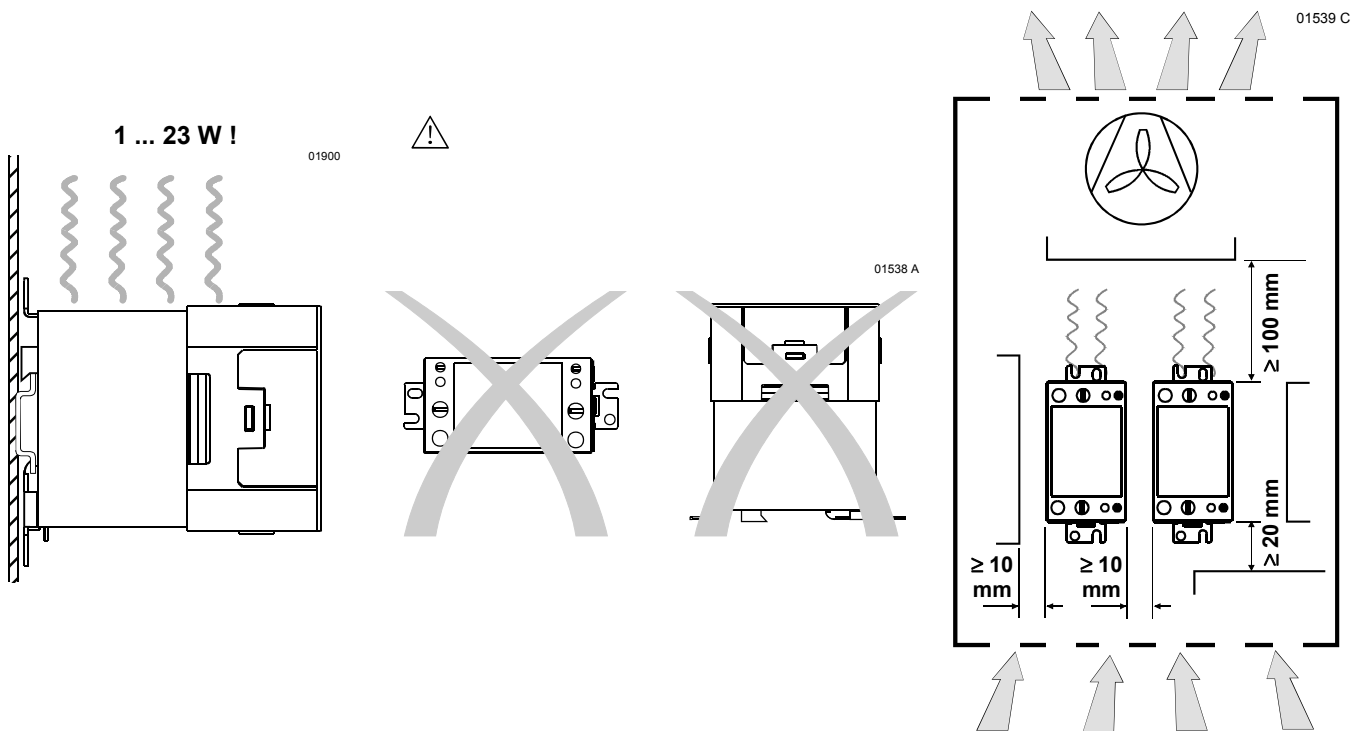

## Disposal



This device is classified as waste electronic equipment under European Directive 2002/96/EC (WEEE) and may not be disposed of as unsorted municipal waste. Adhere to all relevant national laws. Regarding disposal, use the systems setup for collecting electronic waste. Observe all local and applicable laws.

## Technical data

Control side	Control voltage (Terminal G, Y1)	SELV / PELV AC 24 V $\pm$ 20 %		
	Rated voltage	AC 24 V		
	Frequency	50/60 Hz		
	Power consumption (AC 24 V)	0.5 VA		
	Control signal voltage (pulse/pause) (Terminal Y1)	AC 24 V		
	Switch-on voltage	AC 18.5 V		
	Switch-off voltage	AC 6 V		
Load side	Mains voltage (terminal L, Q)	AC 42...660 V		
	Frequency	50/60 Hz		
	Current, $I_{\text{eff}}$ at 40 °C <sup>1)</sup>	Max. 25 A <sup>1)</sup>	Min. 0.15 A	
	Power	0.04 ... 5.75 kW (230V)		
	Power	0.06 ... 10 kW (400V)		
	Power loss across thyristor	1 ... 23 W		
General device data	Switching action	Zero voltage switch		
	Max. cable length (terminals G and Y1) for 0.6 mm diameter Cu cable	300 m		
	Connection terminals on control side	Max 1 x 4 mm <sup>2</sup>		
	Connection terminals on load side	Max 1 x 25 mm <sup>2</sup>		
	Insulation resistance	Control circuit – load circuit	AC 4 kV	
		Load circuit – heat sink	AC 4 kV	
	Housing protection standard	IP 20 to EN 60 529		
Protection class	II to EN 60 730			
Ambient conditions	Normal operation	Transport	Transport	
		IEC 721-3-3	IEC 721-3-2	
	Environmental conditions	Class 3K5	Class 2K3	
		Temperature <sup>1)</sup>	–5...+70 °C <sup>1)</sup>	–25...+70 °C
	Humidity (avoid condensation)	5...95 % rh	<95 % rh	
Mechanical conditions	Class 3M2	Class 2M2		
Standards and directives	Electrical safety			
	Low-voltage switchgear and control gear: AC semiconductor controllers and contactors for non-motor loads)	EN 60947-4-3		
	Electromagnetic compatibility			
	Immunity (industrial & domestic)	EN 61000-6-2		
	Emissions (domestic)	EN 61000-6-4		
	<b>CE</b> conformity			
	Meets requirements of EMC directive	2004/108/EC		
	Low voltage directive	2006/95/EC		
 Reduction of hazardous substances	2002/95/EC			
Weight	Weight excluding packaging	0.360 kg		

<sup>1)</sup> At temperatures above 40°C, the load current must be reduced, see page 3.

## Connection diagrams

### Connection diagram

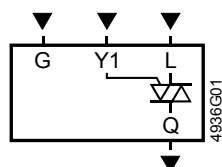

G	System voltage on control side (SELV) AC 24 V
Y1	AC 24 V pulse/pause control signal
L	Mains potential AC 42...660V
Q	Load (resistive)

**Field connection diagrams**

The following field-connection diagrams show only the basic connection of the current valves. The diagrams do not show switch-off functions and overrides. These depend on the plant and can vary from system to system.

Connection diagram 1

**SEA45.1 with and without signal converter:**

1-wire connection plus neutral conductor for AC 42...230 V with 1, 2 and 3 current valves – phases loaded asymmetrically.

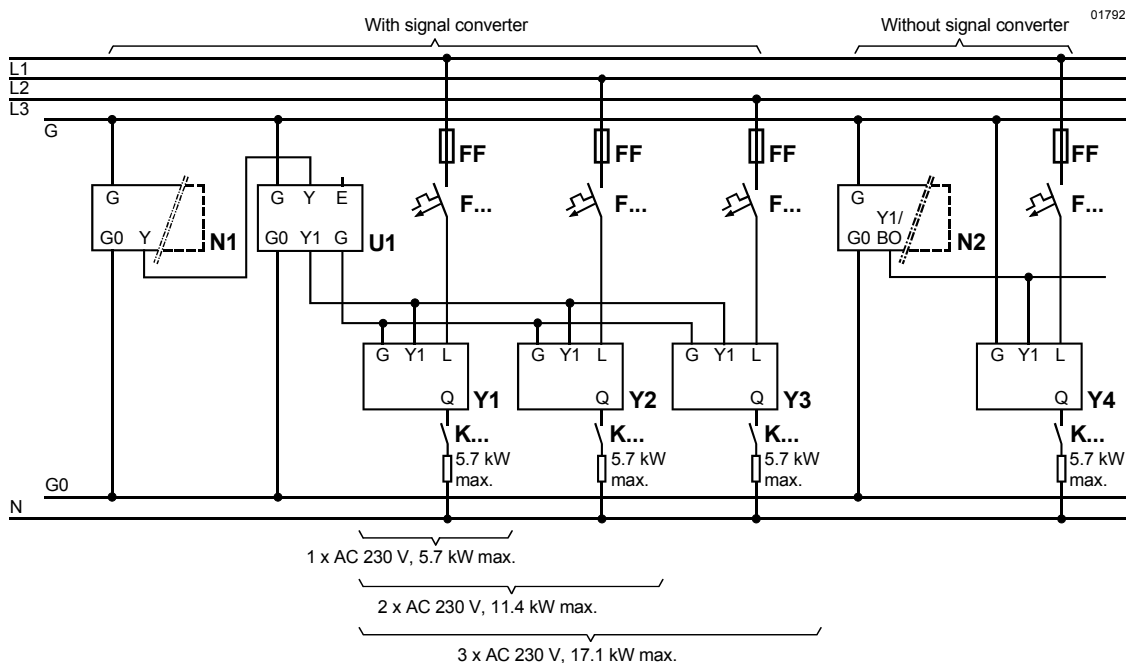

Connection diagram 2

**SEA45.1 with and without signal converter:**

2-wire connection for AC 42...400 V with 1, 2 and 3 current valves – phases loaded asymmetrically –

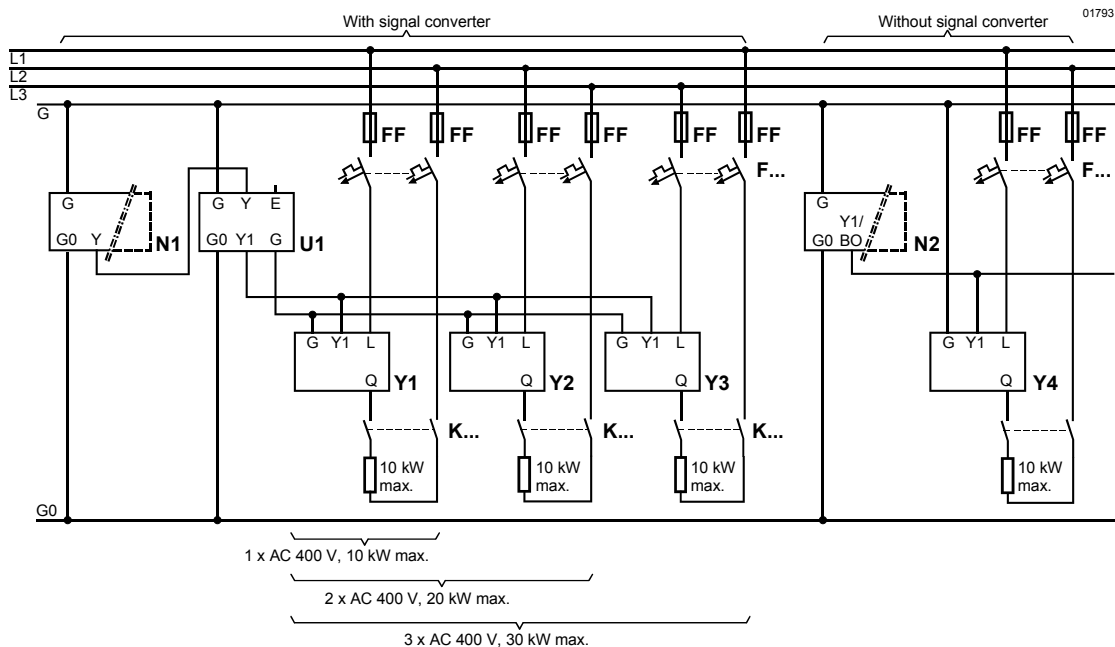

Connection diagram 3  
(standard circuit)

**SEA45.1 with signal converter:**

3-wire connection for AC230 V or AC 400 V – symmetrically loaded phases.

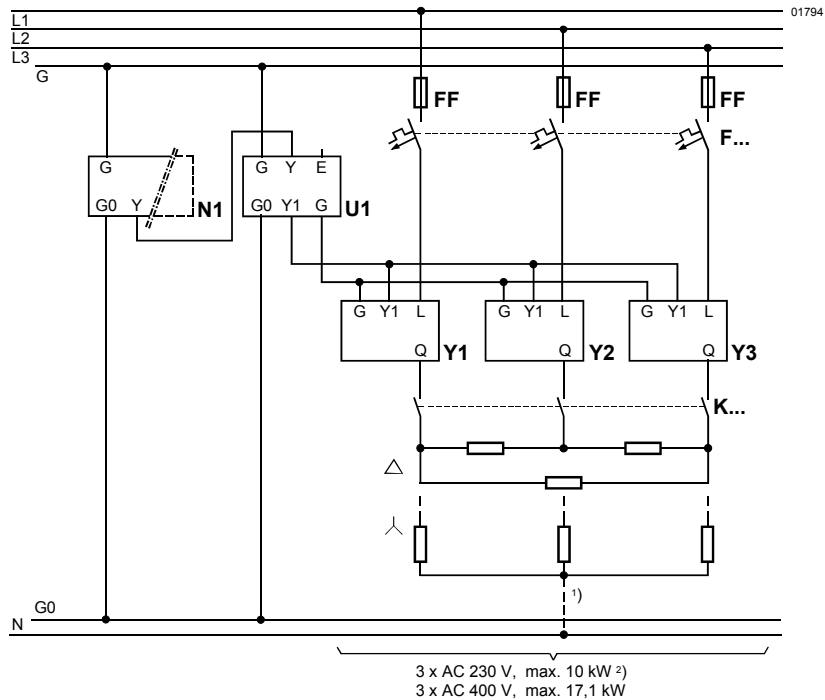

Connection diagram 4  
(economy circuit:  
**CAUTION: Observe all national regulations!**)

**SEA45.1 with signal converter:**

3-wire connection for AC230 V or AC 400 V – symmetrically loaded phases.

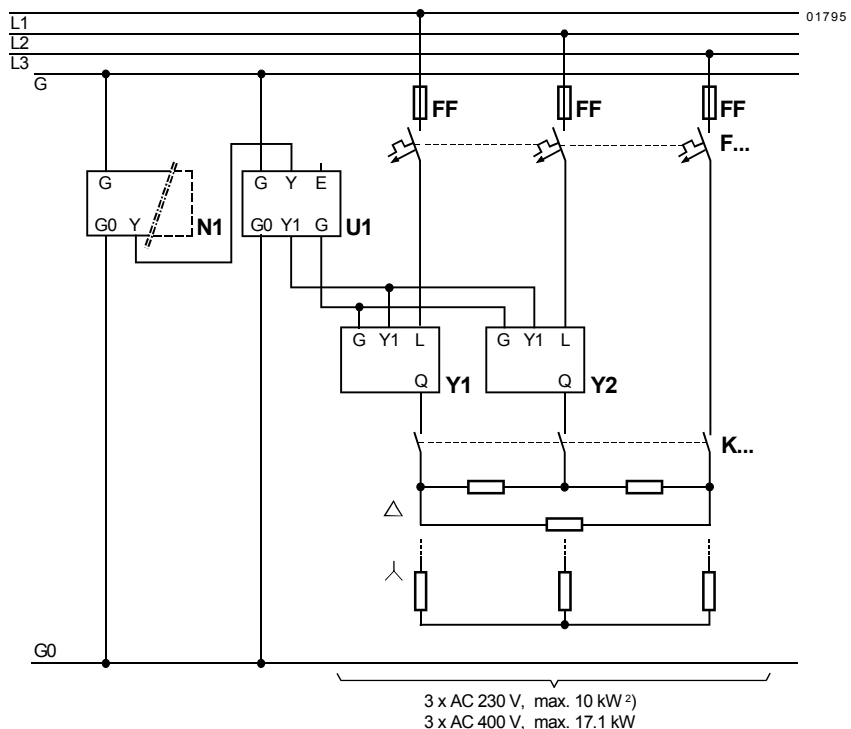

Key to connection diagrams 1 ... 4

- N1 Control unit (e.g. controller) with DC 0...10V or DC 0/10 V output signal
- N2 Control unit (e.g. controller) with AC 24 V pulse/pause output signal
- U1 Signal converter SEM61.4
- Y1...Y4 Current valve SEA45.1
- K... Safety "chain", e.g. safety thermostat and high-temperature cut-out
- FF Very fast-acting fuse
- F... Overcurrent trip

<sup>1)</sup> Star point can be connected to N

<sup>2)</sup> Valid for a voltage of AC 230 V across the conductors

## Dimensions

Dimensions in mm

01901

