

Application

The RXB24.1 room controller is optimized for control of chilled ceiling and radiator systems in individual rooms.

The application of each controller is determined by the application software.

The controllers are delivered with a fixed set of applications, each of which contains various individual applications. The relevant application is selected and activated during commissioning using one of the following tools:

- ETS3 Professional (EIB / KNX Tool Software)
- Synco ACS
- "HandyTool" (the QAX34.3 room unit includes a tool function allowing you to parameterize the connected RXB controller).

Use of spare inputs/outputs

Some of the applications do not make full use of all the inputs and outputs. These I/Os can be used freely in conjunction with a building automation and control system to register digital signals, for example, or to control various items of equipment (ON/OFF or pulse control with AC 24 V).

The inputs can then be read and the outputs controlled via the building automation and control system.

Note Not suitable for time-critical processes <1 s.

Functions

The room controller functions are determined by the selected application and its parameters, and by the input/output configuration.

For details, refer to the CLC and RAD description of functions, document CA110384.

When DESIGO RXB controllers are integrated into a building automation and control system, or into a Synco system, additional functions become available such as time scheduling, central control of setpoints, etc.

Applications

The following applications are available for the RXB24.1 room controllers:

Application group (type)	Applications
CC-02 (with RXB24.1)	CLC01 Chilled ceiling with dew point monitoring
	CLC02 Chilled ceiling with dew point monitoring, radiator with downdraft compensation
	RAD01 Radiator with downdraft compensation

Note Only one application at a time can be activated with the tool (ETS3 Professional, Synco ACS or "HandyTool").

Types

The RXB24.1 room controller has the following outputs:

Type	AC 24 V triac outputs
RXB24.1	For 2 thermic valve actuators or two 3-position actuators
RXZ20.1	Accessories: Terminal covers

Ordering

When ordering please specify the quantity, product name, type code and application group.

Example: **30 Room controllers, type RXB24.1/CC-02**

Compatibility

The RXB24.1 room controller is compatible with field devices from Siemens Building Technologies and with KNX / EIB-compatible third-party devices.

For details, refer to the DESIGO RX hardware overview, CA2N3804.

Design

The RXB24.1 controller consists of a housing base, a housing cover and the printed circuit board with connection terminals. The controller also has a tool socket, a service LED and a programming pin.

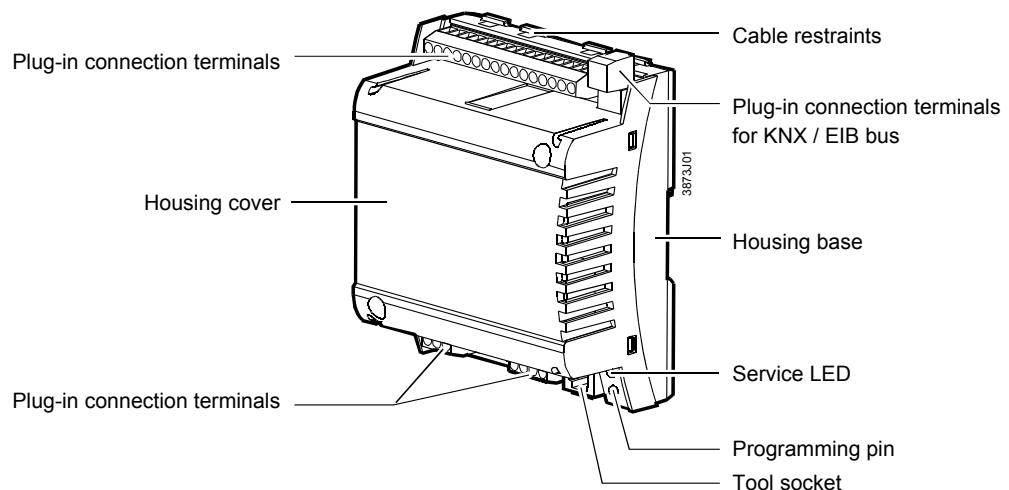

Service LED

The programming LED shows the operational status of the room controller as follows:

Green flashing	OK, device is in operation
Red ON	<ul style="list-style-type: none">• Addressing mode (ACS / ETS)• Fault
Orange / green flashing	Parameter download
OFF	<ul style="list-style-type: none">• No supply voltage• Fault• Service LED disabled by software
Other patterns	<ul style="list-style-type: none">• Start-up (approx. 5.sec)• Fault

Programming pin

The programming pin is used to identify the controller in the commissioning phase.

Pressing this pin causes the red programming LED to light up and remain on until identification of the controller is complete.

Once the programming pin has been pressed, the tool overwrites the hardware address in the room controller.



Note!

If there are no terminal covers fitted, the programming pin may be operated only by a qualified electrician.

The adjacent terminal may be a live mains voltage conductor.

Terminal cover

Terminal covers (RXZ20.1) are available as an option, to protect the connection terminals from physical contact and dirt. The programming LED remains visible when the terminal covers are in place, and the programming pin can be operated with a pointed implement. The cable is connected to the room controller by breaking out the perforated cable entry guide.

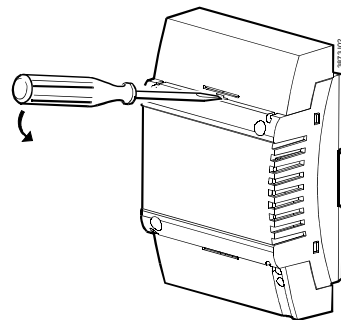

Removing the terminal cover

Label

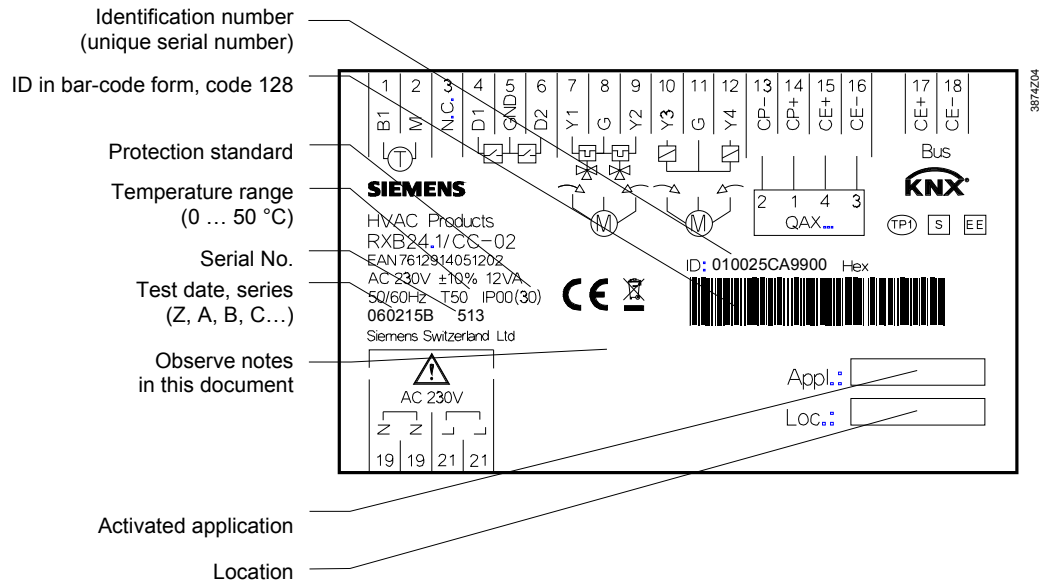

Note Options for use of the labeling fields “Appl.” and “Loc.”:
Handwritten identification of the location and the activated application group.

Connection terminals

All terminals are detachable plug-in screw-terminals. To avoid incorrect wiring, terminals which can be connected to AC 230 V are physically separate from the other terminals.



Note!

The cable restraints on the housing base *must* be used for the connections to terminals 19 ... 21 (AC 230 V). The conductors must be secured with cable ties (see diagram).



Warning!

Ensure that the power is off before inserting or removing plug-in terminals connected to a mains voltage.

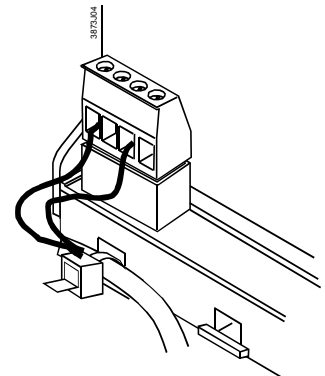

Communication

The RXB24.1 controller communicates with other devices via the following interfaces:

- PPS2 interface (proprietary) for the exchange of data with the room units
- KNX / EIB bus (terminals CE+ and CE-) for communication with:
 - PX/KNX interface (to DESIGO INSIGHT)
 - Interface OCI700 (to Synco)
 - Other DESIGO RXB controllers
 - KNX / EIB compatible field devices (e.g. temperature sensor)

Connecting the tool

To facilitate commissioning, the tools ETS3 Profession or Synco ACS can be connected at three different points (marked **(A)** in the diagram) in the plant:

- to the KNX / EIB bus cable at any point
- to the RXB2... controller (RJ45 tool socket)
- to the room unit (RJ45 tool socket)

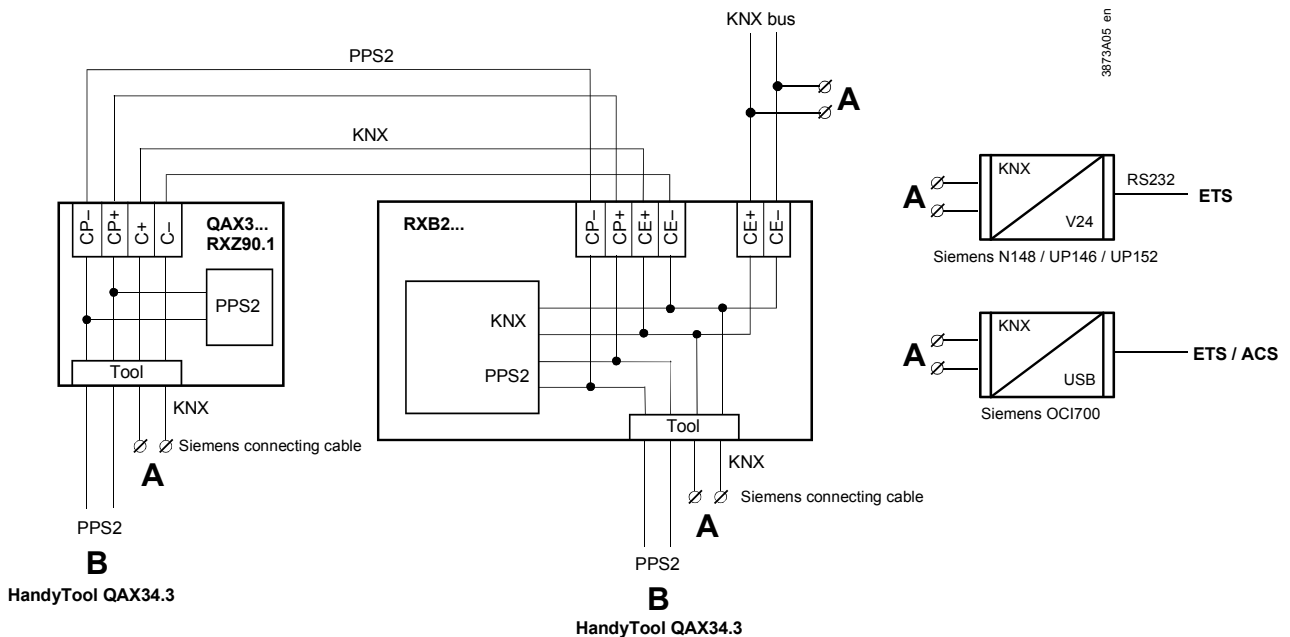

Notes



Caution!

- The tool socket is a proprietary socket. A Siemens connecting cable must be used (e.g. PXA-C1).
- **When connected to Ethernet, the device on the other end may be damaged!**
- The tools ETS3 and ACS, even if connected to a tool socket, require an interface:
 - RS232 KNX/EIB interface (ETS3)
 - OCI700 USB-KNX / EIB interface (ETS3 , ACS).
- The "HandyTool" is connected to the tool socket of the room controller or to the tool socket of the room unit (QAX3..., RXZ90.1) (**B**).
- If you use OCI700 as an interface, it is connected to the service plug of the controller or of the room unit. **As long as the OCI700 is connected to the service plug, it must be supplied by the computer via the USB interface.** Otherwise the LCD display of the room unit will turn dark and the controller will switch to addressing mode.

Disposal



The device is classified as waste electronic equipment in terms of the European Directive 2002/96/EC (WEEE) and should not be disposed of as unsorted municipal waste.

The relevant national legal rules are to be adhered to.

Regarding disposal, use the systems setup for collecting electronic waste. Observe all local and applicable laws.

The KNX / EIB Building Services Management Manual and system principles supplement (see "Reference documentation", page 10) contains the information relevant for the engineering of the KNX / EIB bus (topology, bus repeaters, etc.) and for the selection and dimensions of connecting cables for the supply voltage and field devices.

AC 230 V supply cables

- The RXB24.1 room controller operates with a mains supply voltage of AC 230 V. The controlled devices (valve actuators) receive their power directly from the room controller. This means that a separate AC 24 V supply is not necessary for the controllers and associated field devices.
- The sizing and fuse protection of the power supply cables depends on the total load and on local regulations. The power supply cables connected to the room controller must be secured with cable restraints.
- If serial wiring is applied on the terminal block 19/21, the connection will be interrupted if the block is removed from the controller (the jumpers 19-19 and 21-21 are on the PCB, not in the block, see terminal diagrams on pages 11 and 12)
- The supply cables must be secured with cable restraints.

AC 24 V triac outputs

The **simultaneous** load on outputs Y1 ... Y4 must not exceed 9.5 VA.

Example:

Y1 (heating)	2 thermic valve actuators, type STP72E / STA72E	5 W
Y2 (cooling)	2 thermic valve actuators, type STP72E / STA72E	5 W

The maximum load is 9.5 VA for the heating sequence and 9.5 VA for the cooling sequence.

This is acceptable because the two sequences never operate at the same time.



Note!

With low loads (< 2VA) the voltage tolerance may be greater than +20% (see technical data).

Mounting instructions

The room controllers can be mounted in any orientation, and fixed as follows:

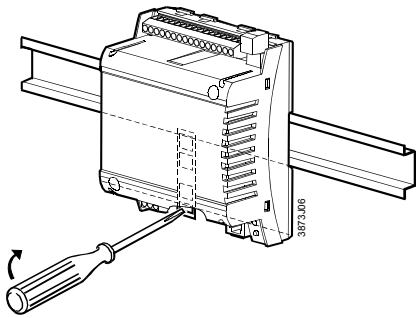

Rail mounting

The housing base is designed for snap-mounting on DIN rails, type EN50022-35 x 7.5 (can be released with a screwdriver).

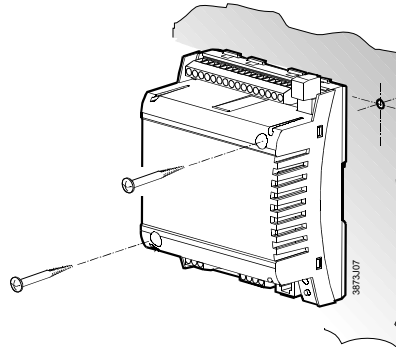

Surface mounting

There are two drill holes for screw-mounting (see "Dimensions" for drilling template). The housing base is fitted with raised supports.

Screws: Max. diameter 3.5 mm, min. length 38 mm



Note!

Tightening torque for fixing screws max. 1.5 Nm

When mounting note the following:

- The controller should not be freely accessible after mounting. It must be mounted in a cabinet or behind a cover that can only be opened / removed with a key or a tool.
- Ensure adequate air circulation to dissipate heat generated during operation.
- Easy access is required for service personnel
- Local installation regulations must be observed.

Mounting instructions and a drilling template are printed on the controller packaging.

Commissioning

The RXB24.1 room controller is commissioned with either the ETS3 Professional or the Synco ACS tool

- via the RS232-KNX / EIB interface, or
- via the USB-KNX / EIB interface (OCI700), or with the HandyTool" via PPS2

Labeling

The definitive application and the controller's location are handwritten in the labeling fields "Appl." and "Loc" in the commissioning stage.

Function test

A special test mode (ETS3 Professional and HandyTool) is available for operation of the outputs and interrogation of the inputs.

**Note!**

- In the event of a long-term short circuit (approx. 4 minutes) or overload, the thermal fuse in the transformer may trip. Subsequently, the device must be exchanged.
- There is no protection against accidental connection on the AC 24 V side.
- Mains AC 230 V for the supply must be disconnected before plugging and unplugging the terminal blocks (danger of electric shock!)
- If serial wiring is applied on the terminal block 19/21, the connection will be interrupted if the block is removed from the controller (the jumpers 19-19 and 21-21 are on the PCB, not in the block, see terminal diagrams on pages 11 and 12).

Technical data

▲ Power supply	Operating voltage	AC 230 V ± 10 %
	Rated voltage	AC 230 V
	Frequency	50/60 Hz
	Power consumption with connected field devices	Max. 12 VA
	Internal fuse	Thermal, non-resetting
Operating data	Control algorithm	PI
Inputs		
Signal inputs D1, D2 (for volt-free contacts)	Quantity	2
	Contact voltage	DC 16 V
	Contact current	DC 5 mA
	Contact transfer resistance	Max. 100 Ω
	Contact insulation resistance	Min. 50 kΩ
	Switch time:	min. 20ms "ON", min. 20ms "OFF"
Measured value input B1	Compatible temperature sensors	LG-Ni 1000
	Quantity	1
	measuring range	0 ... 50 °C
	Sensor current	0.5 mA
	Resolution	0.1 K
	Measuring error at 25 °C sensor temp. (without cable)	max. 0.5 K
Outputs		
AC24 V triac outputs , Y1 ... Y4	Quantity	4
	Output voltage	AC 24 V ON/OFF, PWM or 3-position: +/-20% (May exceed +20% with loads under 2VA)
	Permissible load current	Max. 0.5 A
	Power limitation	No internal limitations
	Total nominal load (at both outputs simultaneously)	Max. 9.5 VA (e.g. 2 thermic actuators, type STP72E per heating and cooling sequence)
Ports/interfaces		
Interface to room unit	Number of room units connectable	1
	Interface type for room unit	PPS2
	for ETS3 Professional / ACS	KNX / EIB bus
	PPS2 baud rate	4.8 kbit/s
	Baud rate on KNX / EIB bus	9.6 kbit/s
KNX / EIB bus	Interface type	KNX / EIB (electrically isolated)
	Transceiver	TP-UART
	Bus current	5 mA
	Baud rate	9.6 kbit/s
	Bus topology	Refer to KNX / EIB manual (Reference documentation, see next page)

Cable connections	Connection terminals for signals and power supply (plug-in screw terminals)	Solid or stranded conductors 0.25 ... 2.5 mm ² or 2 x 1.5 mm ²		
	KNX / EIB bus connection terminals (plug-in screw terminals)	Solid or stranded conductors 2 x max.1.0 mm ² e.g. YCYM 2x2x0.8		
	Single cable lengths	For field devices, see also the RXB & RXL installation guide, CM110381		
	Signal inputs D1, D2	Max. 100 m with diameters ≥ 0.6 mm		
	Measured value input B1	Max. 100 m		
	AC24 V triac outputs , Y1 ... Y4	Max. 100m where A ≥ 1.5 mm ²		
	Interface to room unit	Max. 115 m where A= 0.75 mm ² (including connecting cable for tool)		
	Cable type	4-core, twisted pair, unscreened		
	KNX / EIB bus	Max. 500 m		
	Cable type	Refer to KNX / EIB manual (see "Reference documentation" below)		
	Tool connecting cable	Max. 3 m		
Housing protection standard	Protection standard to EN 60529	IP30 with terminal cover fitted and wall mounted without DIN rail IP20 for all other mounting arrangements		
Protection class	Suitable for use in systems with protection class I or II			
Ambient conditions	Normal operation	Class 3K5 to IEC 60721-3-3		
	Temperature	0 ... 50 °C		
	Humidity	< 85 % rh		
	Transport	Class 2K3 to IEC 60721-3-2		
	Temperature	- 25 ... 65 °C		
	Humidity	< 95 % rh		
Standards and directives	Product safety			
	Automatic electronic controls for household and similar use	EN 60730-1		
	Electromagnetic compatibility			
	Immunity (industrial & domestic)	EN 60730-1		
	Emissions (domestic)	EN 60730-1		
	Home and Building Electronic Systems (HBES)	EN 50090-2-2		
	Electronic individual zone control equipment	EN 15500		
	CE compliance			
	Meets requirements of EMC Directive	2004/108/EC		
	Low Voltage Directive	2006/95/EC		
	C -Tick conformity (EMC)	AS/NZS 61000-6-3		
	Konnex compliance	Certified		
eu.bac	Meets the requirements for eu.bac certification			
	See product list at: http://www.eubacert.org/licences-by-criteria.asp			
	Type	License	Application	Control accuracy [K]
	RXB24.1/CC02	20858	Heating Systems (Radiator)	0.4
			Chilled Ceiling Systems	0.3
		Reduction of hazardous substances	2002/95/EC	
Dimensions	See dimension diagrams			
Weight	excluding packaging		0,610 kg	
	including packaging		0,650 kg	

Reference documentation

- Building Services Management Manual – Fundamental principles
- Building Services Management Manual – Applications

Zentralverband Elektrotechnik- und Elektronikindustrie e.V. (ZVEH)
(Central association for the electrical and electronic engineering industry)
 Stresemannallee 19D-60596 Frankfurt a. M, Germany.

RXB24.1

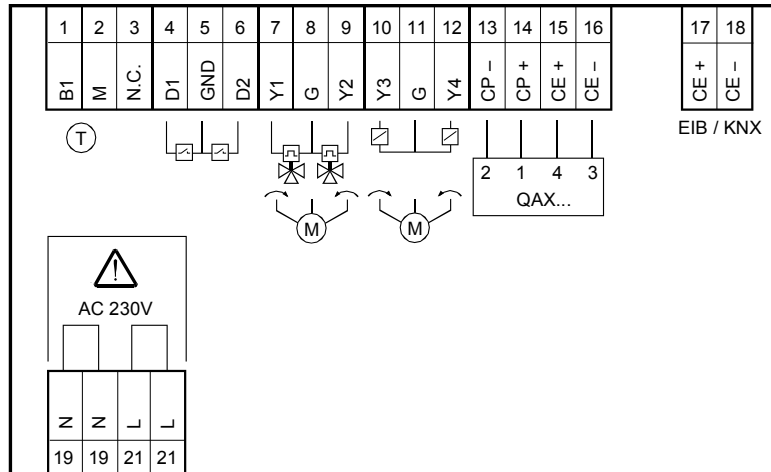

Measured value input

- B1 1 Measured value input for LG-Ni 1000 sensors
- M 2 Measured value input ground

Signal inputs

- D1 4 Signal input
- GND 5 Signal ground
- D2 6 Signal input

Triac outputs

- Y1 7 AC 24 V, 0.5 A switching output
- G 8 AC 24 V actuator supply
- Y2 9 AC 24 V, 0.5 A switching output
- Y3 10 AC 24 V, 0.5 A switching output
- G 11 AC 24 V actuator supply
- Y4 12 AC 24 V, 0.5 A switching output

Room unit

- CP- 13 PPS2 ground
- CP+ 14 PPS2 data
- CE+ 15 KNX / EIB data cable
- CE- 16 KNX / EIB data cable

KNX / EIB bus (plug-in connection)

- CE+ 17 KNX / EIB data cable
- CE- 18 KNX / EIB data cable

Power supply

- N 19 Neutral conductor
- R 21 Phase conductor AC 230 V +/- 10 %

Caution

- **Local installation regulations must be observed.**

Tool socket

Proprietary RJ45-type tool socket

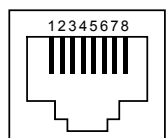

- 1 KNX / EIB data cable (CE+)
- 2 KNX / EIB data cable (CE-)
- 3 Not used
- 4 Not used
- 5 +12VDC
- 6 RxD
- 7 PPS2 (CP+) / TxD
- 8 PPS2 (CP-)

Connection of field devices, room unit, KNX / EIB bus and power supply

3874A11

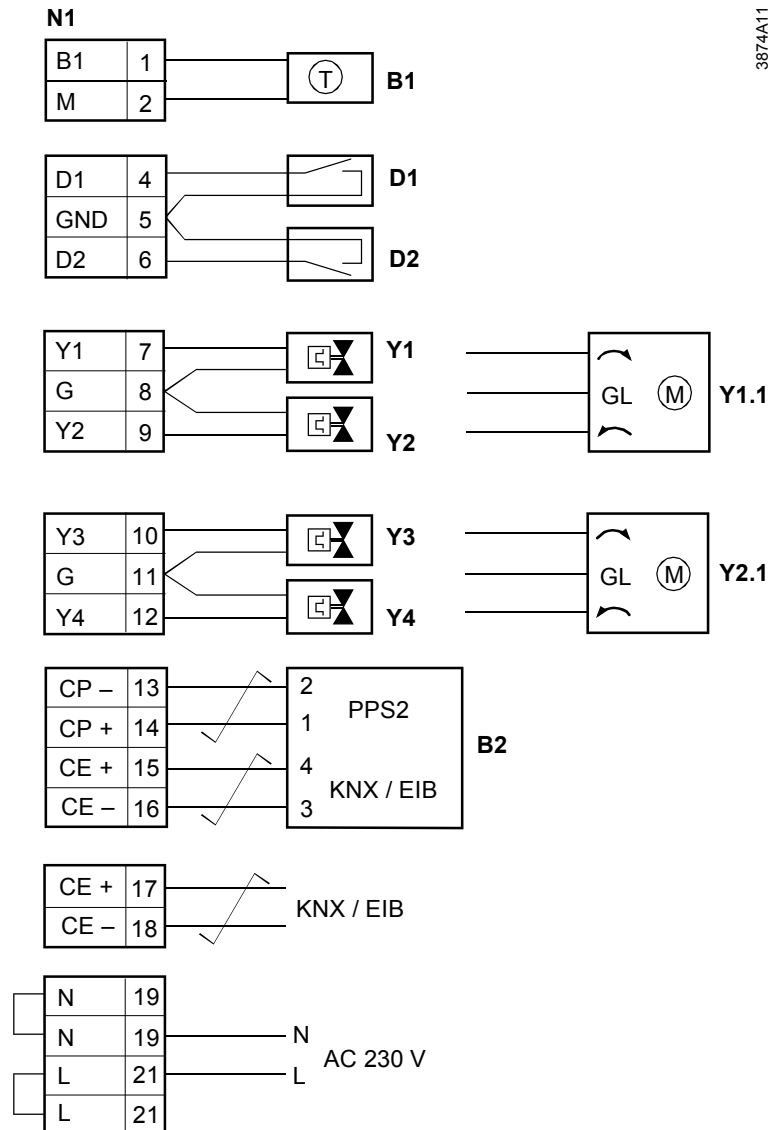

- N1 RXB24.1
- B1 LG-Ni 1000 temperature sensor
- D1, D2 Volt-free contacts (window contact, occupancy sensor, etc.)
- Y1...Y4 AC 24 V thermic valve actuators
- Y1.1 Motorized AC 24 V, 3-position valve actuator
- Y2.1 Motorized AC 24 V, 3-position valve actuator
- B2 QAX... room unit

Twisted pair

Note For information on the compatibility of field devices with the RXB24.1 room controller, refer to the various application descriptions (see the CLC and RAD description of functions, document CA110384)

Parallel connection of several thermic valve actuators

Up to two thermic actuators per sequence may be connected directly to the room controller. With more than two thermic actuators, a UA1T power amplifier is required.

The principle is the same for output Y2. Do not exceed the maximum simultaneous load on outputs Y1 and Y2 (max. 9.5 VA).

Power consumption at input X1 of the UA1T: 0.5 VA.



Note!

Mixed operation: It is not permissible to connect thermic actuators both to the controller and to the power amplifier.

Owing to the difference in voltage between the controller's internal transformer and the power supply of the UA1T, this could cause the valve positions to deviate substantially.

Connection to the controller

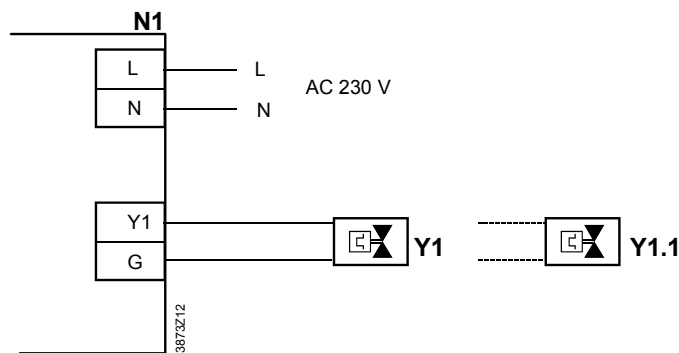

Connection to the power amplifier

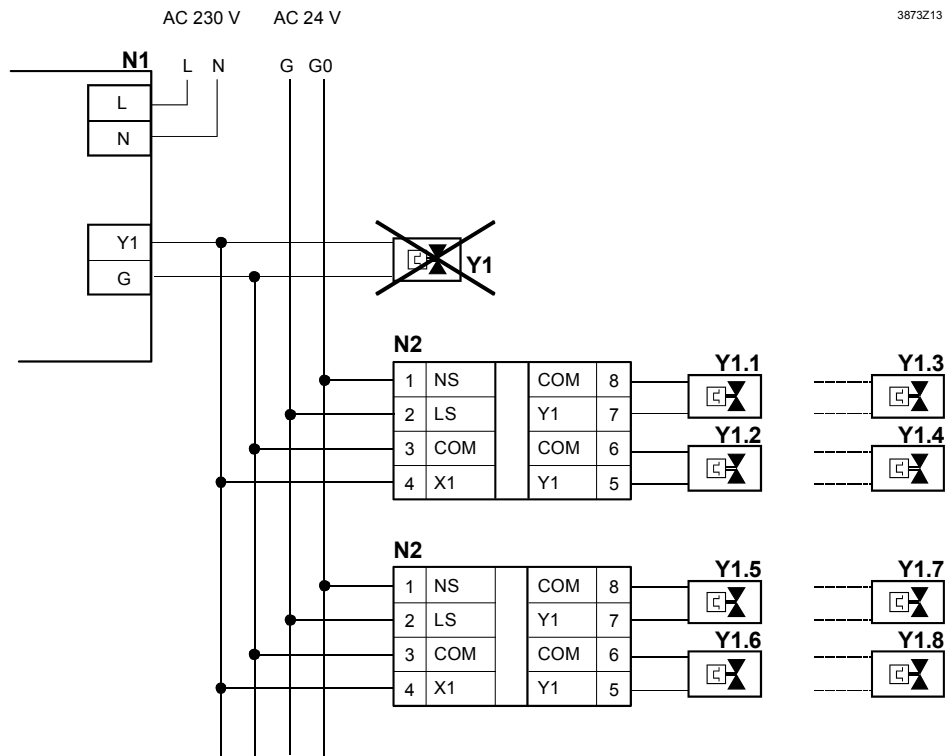

- N1 Room controller RXB24.1
- N2 UA1T power amplifier (see data sheet CA2N3591)
- Y1 AC 24 V thermic valve actuators connected to the controller
- Y1.x AC 24 V thermic valve actuators (max. 2 STA72E/STP72E actuators per Y1 output on the UA1T)

Notes

- The UA1T requires an AC 24 V supply voltage
- The UA1T is *not* suitable for the connection of 3-position actuators.

Dimensions

Dimensions in mm

Without terminal cover

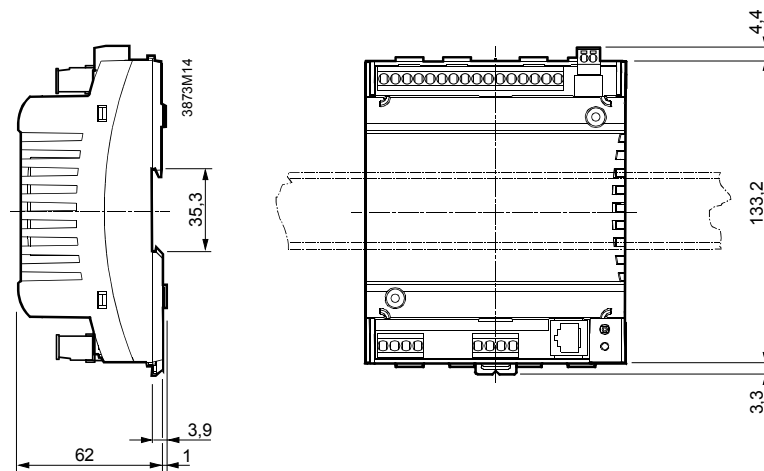

With terminal covers

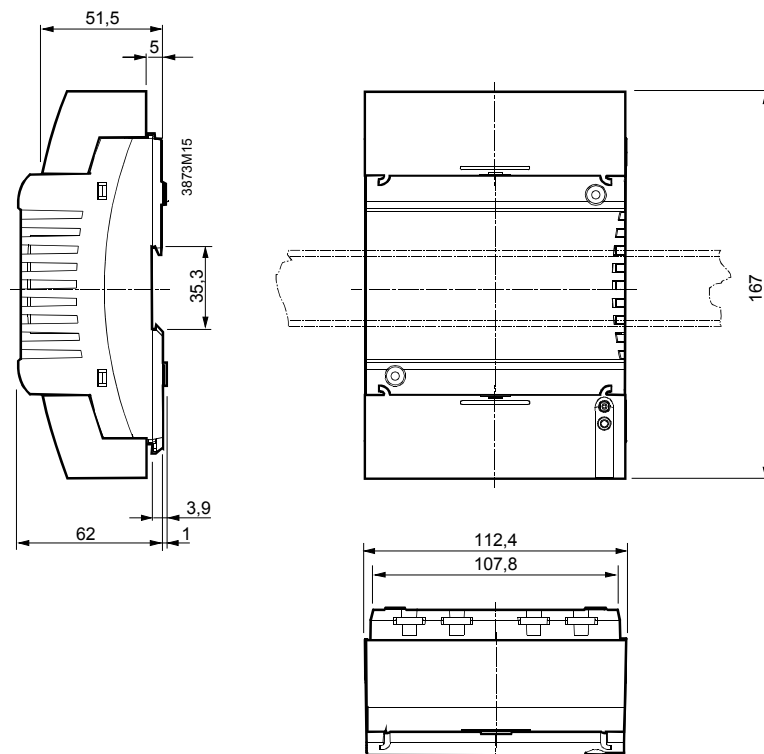

Drilling diagram (1:1)

