



Synco™ living

## Starter kit

Room unit with 1 radiator control actuator

**KIT911**

Room unit with 4 radiator control actuators

**KIT914**

- 
- **Wireless room temperature control system for heating applications consisting of:**
    - One QAW912 room unit
    - One or four SSA955 radiator control actuators
  - **The starter kit can be extended with additional SSA955 units to a maximum of 6 radiator control actuators**
  - **RF communication based on KNX standard (868 MHz bidirectional)**
  - **Room temperature control for up to 2 heating zones**
  - **Operation and display of heating functions**
  - **Acquisition of room temperature via QAW912 and a SSA955**
  - **Battery operation with standard 1.5 V batteries**

## Use

---

- Selection of room operating mode, activation of comfort timer/absence timer, and setting time switch, holiday duration and room temperature setpoints
- Display room heating function and status messages (including all radiator control actuators connected via RF)
- Acquisition of the room temperature of both heating zones
- Can be deployed in heating plants to actuate Siemens and other suppliers' radiator valves
- Use max. 6 radiator control actuators grouped in one zone or distributed on two zones
- Acquire heat demand from both zones and transmit to heat generation via RRV912 relay contact or KRF960 RF adapter plug
- No tool is needed for commissioning.
- Deployed especially for:
  - Renovation market
  - Difficult wall mounting (sandstone, glass, etc.)
  - Flexible room design (changing decorations, different furniture)
  - New buildings
- With the exception of the QAW912, all devices of the starter kit can continue to be used when a plant is extended by the Synco living central apartment unit

## Equipment combinations

---

The starter kit can be used together with the following Siemens Synco living products:

Device designation	Type	Documentation
Integration of other radiators:		
Radiator control actuator	SSA955	N2700en
Transmit heat demand:		
Heating circuit controller	RRV912	N2705en
RF adapter plug, switching	KRF960-x	N2718en

Refer to data sheets N2700en or N2179e "Radiator valve accessories" for specific information on valve and valve adapter combinations for the SSA955.

## Ordering

---

When ordering, please specify quantity, product number (SSN), and product designation.

Order valves and valve adapters separately.

## Scope of delivery

The starter kit is supplied with multilingual instructions (G2720xx), alkaline batteries and required fittings.

Order numbers	Type (ASN)	Product number (SSN)	Product designation
	QAW912	S55621-H102	Room unit - 2 heating zones
	KIT911	S55621-H103	Starter kit - 1 actuator
	KIT914	S55621-H104	Starter kit - 4 actuators

## Functions

---

<b>Main function</b>	The QAW912 manages room heating control for up to 2 heating zones and 6 SSA955 radiator control actuators. The QAW912 allows for operating all room heating functions while all data is displayed clearly on the display. At the same time, the QAW912 measures the room temperature in the first zone and can pass on by radio the acquired heat demand of both zones.
<b>Room operating mode</b>	The room operating mode can be changed over between Automatic, Manual Comfort, Manual Economy, and Manual Protection using the "Mode" button on the QAW912. The room operating mode acts on both zones.
<b>Time switch</b>	A separate time switch offering 6 switching points a day is available for each zone, allowing for changeover between Comfort and Economy setpoints. The current day profile is displayed graphically on the QAW912.
<b>Room temperatures</b>	The QAW912 measures the room temperature of the first zone. The room temperature of the second zone is measured via the SSA955 lead controller's internal sensor and transmitted to the QAW912. Both room temperatures are displayed on the QAW912. Three different setpoints (Comfort, Economy, and Protection) can be entered for both zones.
<b>Year clock</b>	The QAW912 has a year clock with automatic changeover between daylight saving time and standard time.
<b>Timer function</b>	The timer function can activate Comfort or Economy mode for both zones for up to 96 hours. Pressing the Timer/Prog button on the QAW912 activates and displays the timer function. The Mode button allows for switching between Comfort and Economy. Economy operation is used to save energy during short periods of absence. The original room operating mode is restored automatically after the set period expires. The timer function acts on both zones.
<b>Holiday function</b>	A holiday period in days can be entered on the QAW912 for both zones for extended periods of absence. Protection or Economy mode may be selected as the holiday operating mode. After the holiday period expires, the original room operating mode is restored automatically. The active holiday function is displayed on the QAW912.
<b>Optimum start / stop control</b>	The QAW912 continuously acquires the heating and cooling behavior for the heating zones. Thus, the switch on / off times for heating per zone can be shifted forward such that when the time switch changes the temperature level in automatic mode, the desired room temperature is attained at exactly the time entered. The forward shift is displayed on the QAW912. The maximum forward shift for optimum start control (change to Comfort mode) can be set in a range from 0 (no optimum start control) to 48 hours. The maximum forward shift for optimum stop control (change to Economy mode) can be set in a range from 0 (no optimum stop control) to 6 hours.

<b>Heat demand</b>	The QAW912 generates the heat demand signal from the present valve positions of the two zones. The heat demand signal is forwarded as a switching command via RF to the RRV912 or KRF960.
<b>Parallel operation of radiator control actuators</b>	A maximum of 6 radiator control actuators SSA955 can be operated: Grouped for one zone or distributed on any two zones. The first radiator control actuator connected (lead controller) assumes actual room control and controls via radio the other radiator control actuators (parallel controllers) assigned to the same zone.
<b>Anti-lime function</b>	The QAW912 triggers an anti-lime function each Monday at 10:00 am to prevent the valve plug from sticking when the plant is not operated for extended periods of time. Here, the valve actuators fully open and close once (valve kick). The anti-lime function acts on all SSA955 radiator control actuators.
<b>Silent mode</b>	In noise-sensitive rooms (e.g. bedrooms), SSA955 radiator control actuators can be operated at a reduced noise level by zone. The SSA955 requires more actuator energy in silent mode which reduces battery life.
<b>Special SSA955 functions</b>	The SSA955 integrated in the starter kit supports supplemental, autonomous functions, e.g. calibration. The exact function descriptions can be found in data sheet CE1N2700en for the SSA955.
<b>Communication</b>	All devices from the starter kit communicate via radio.
<b>Create radio connections</b>	Selecting the corresponding function (Zone 1, Zone 2, or heat demand) on the QAW912 and pressing the connection, function button on the corresponding component connects individual RF components to the QAW912.
<b>Display device list</b>	A list with all connected RF devices is maintained in the QAW912 to check connections.
<b>Binding test</b>	After activating test mode on the QAW912, the binding test for individual peripheral devices is triggered via the binding or the multifunction button. An optical and acoustic signal indicates error-free connections on the QAW912.
<b>Device monitoring</b>	QAW912 monitors the connected SSA955 radiator control actuators. An error message is displayed when there is no RF communication.
<b>RF failure</b>	The SSA955 radiator control actuators autonomously control to a room temperature setpoint of 21 °C using the internal room temperature sensor when RF communication is interrupted between the QAW912 and the components to be controlled. The components return to the original control mode after RF communication is reestablished.
<b>QAW912 failure</b>	The SSA955 radiator control actuators use the internal room-temperature sensor to autonomously control to a room temperature setpoint of 21 °C.
<b>Supply state</b>	The multifunction button can be used to reset the QAW912 to its supply state. The complete starter kit system must then be reconnected.
<b>Error messages / maintenance messages</b>	The QAW912 displays internal as well as error and maintenance messages of partner devices:

Error messages	Symbols	Description
LbAt		Battery capacity low QAW912 or SSA955 (Low Battery)
noCo		RF communication error (no Communication)
CLoc		Invalid time (Clock).
CAli		Calibration error for SSA955 (Calibration)
noLc		No lead controller bound (no Lead Controller), configuration error
SEnS		Defective room temperature sensor QAW912 or SSA955 (Sensor)

## Operating and display elements

### QAW912

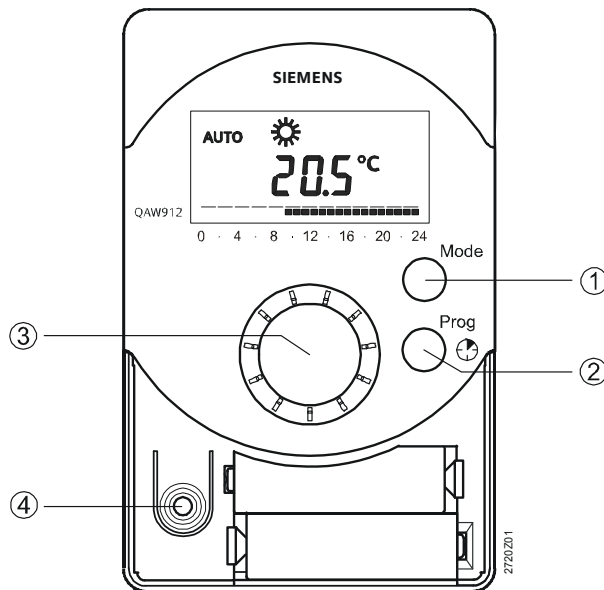

Operating elements	Function
① Mode button	<ul style="list-style-type: none"> <li>- Selection of operating mode (Automatic, Manual Comfort, Manual Economy, Manual Protection)</li> <li>- Selection of timer operating mode (Comfort, Economy)</li> <li>- Leaving programming or commissioning mode.</li> </ul>
② Timer/Prog button	<ul style="list-style-type: none"> <li>- Activation and setting of timer function</li> <li>- Activation of programming mode</li> <li>- Switching between value adjustment and line selection</li> </ul>
③ Setting knob	<ul style="list-style-type: none"> <li>- Selection of various information displays</li> <li>- Selection of operating line and adjusting values in programming or commissioning mode</li> </ul>
④ Multifunction button (under the battery cover)	<ul style="list-style-type: none"> <li>- Activation of commissioning mode</li> <li>- Deleting device from the device list</li> <li>- Reestablish supply state</li> </ul>

Additional information on function and operation of the QAW912 is available in the inserted instructions (G2720xx).

### SSA955

The exact description of operating and display elements for the SSA955 can be found in data sheet CE1N2700en.

**Mounting location**

Mount the QAW912 in the building on an interior wall, approximately 1.5 meters above the floor. The following conditions are required for the device to acquire the air temperature in the room as accurate as possible:

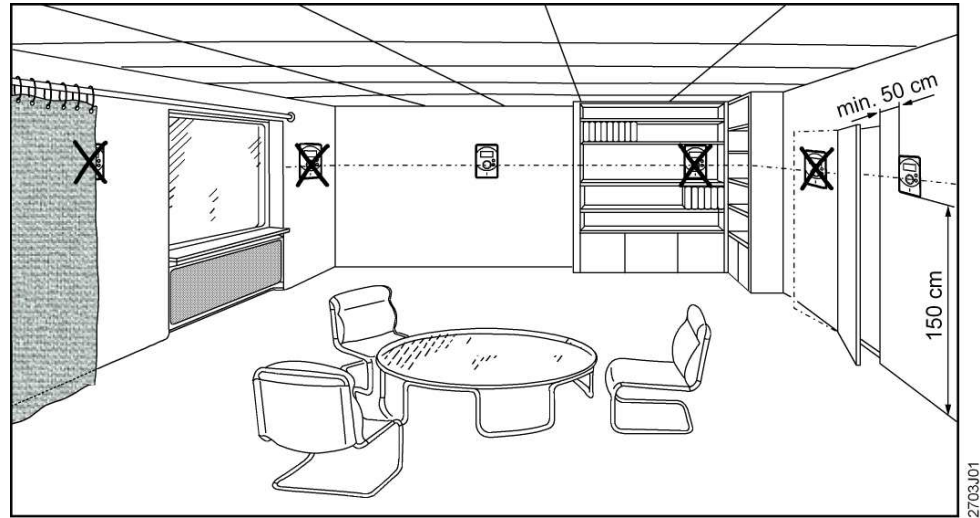

- Do not mount the QAW912 on an exterior wall, in niches, bookshelves, behind doors or curtains
- Do not expose the temperature measurement to the influence of direct sunlight, in a draft or other source of heat or cold
- Observe permissible environmental conditions
- Do not expose the device to dripping water
- Notes on engineering and mounting RF devices for the Siemens system Synco living are available in the communications data sheet CE1N2708en. Please note that RF repeaters cannot be used with the QAW912
- Mount the unit's wall base on a flat wall
- Maintain a minimum clearance of 60 mm at the bottom to open the battery compartment

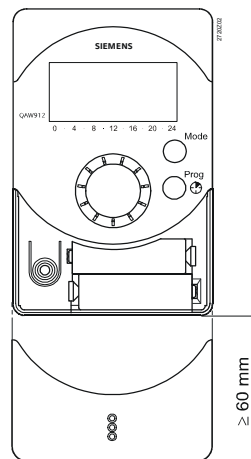

**Mounting**

The QAW912 is mounted on a base on the wall and fits most standard recessed conduit boxes.

**Note**

First mount the QAW912 and then insert the batteries.

**Commissioning**

Prior to commissioning, check to ensure that the QAW912 is properly mounted on the wall and whether the batteries were correctly inserted.

**Maintenance**

The QAW912 is maintenance free.

**Change battery**

The QAW912 signals when a battery change on the device or on a SSA955 is required. The batteries are located in the battery compartment. Batteries can be replaced in a mounted device and there is no need for using tools.

**Disposal**

In terms of disposal, the devices are classified as electronic scrap conforming to the European Directive 2002/96/EG (WEEE) and must not be disposed of as domestic waste. The relevant national legal regulations must be complied with. The sensor must be disposed of through the relevant channels. Local and currently valid legislation must be observed. Exhausted batteries must be disposed of in compliance with environmental regulations.

**Notes on SSA955**

See data sheet CE1N2700en for notes on engineering, mounting and operating the SSA955.

**Warranty**

---

The application-related technical data are guaranteed exclusively with the device combinations described herein.

**Siemens provides no service or warranty claims for other device combinations.**

## Technical data

### QAW912

Power supply	Type of battery	2 x Alkaline batteries LR6 (AA); 1.5 V		
	Battery life (capacity $\geq$ 2.5 Ah)	Typically 2 years		
	reverse voltage protection	Integrated		
RF	Frequency	868 MHz, bidirectional		
	Range	Typically 30 meter in the building		
	RF protocol	KNX RF compatible 		
Temperature sensor	Sensing element	NTC 10 kOhm resistor		
	Measuring range	0... 50 °C		
	Time constant	20 minutes		
Display	Type	Segment LCD		
	Resolution	0.1 °C		
Standards	<b>CE</b> Conformity to			
	EMC directive	2004/108/EC		
	- Immunity, emissions	- EN 60730-1		
	Suitable for use in residential and industrial environments			
	Low voltage directive	2006/95/EC		
- Electrical safety	- EN 60730-1			
RTTE (Radio & Telecom. Equipment)	1999/5/EC			
- Wireless communications	- EN 300220-2, EN 301489-1, EN 301489-3			
Degree of protection	Safety class	III to EN 60730		
	Housing	IP40 to EN 60529 (completely mounted)		
	Degree of pollution	2 to EN 60730		
Environmental compatibility	Environmental product declaration	ISO 14001 (Environment)		
	CE1E2703en provides information on environmentally compatible product design and assessment (RoHS compliance, composition of substances, packaging, environmental benefit and disposal)	ISO 9001 (Quality)		
		SN 36350 (Environmentally compatible products)		
		RL 2002/95/EC (RoHS)		
Dimensions	Refer to "Dimensions"			
Weight	Unit complete with accessories	QAW912	KIT911	KIT914
		0.630 kg	0.940 kg	1.880 kg
Housing material	Plastic ASA+PC			
Housing color	White NCS S 0502-G			
Ambient conditions		<b>Operation</b>	<b>Transport</b>	<b>Storage</b>
		EN-60721-3-3	EN-60721-3-2	EN-60721-3-1
	Environmental conditions	Class 3K5	Class 2K3	Class 1K3
	Temperature	0... +50 °C	-25... +70 °C	-20... +65 °C
	Humidity	5...95% r.h. (non-condensing)	<95% r.h.	5...95% r.h.
	Mechanical conditions	Class 3M2	Class 2M2	Class 1M2
	Maximum elevation above sea level	Min. 700 hPa, corresponding to max. 3000 meters above sea level		

### SSA955

Technical data for the SSA955 are available in data sheet CE1N2700en.



## Dimensions

### QAW912

Dimensions in mm

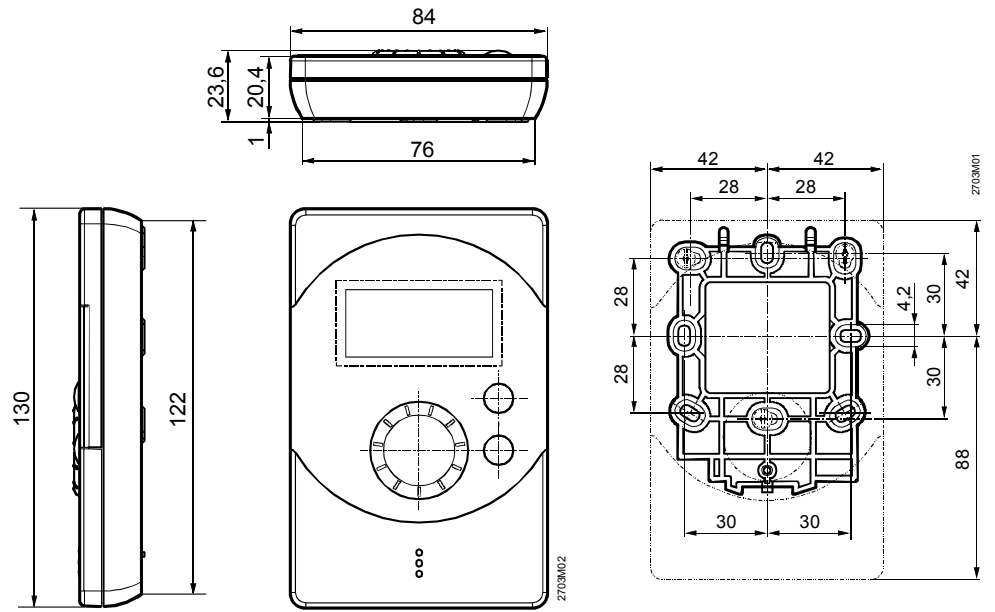

### SSA955

Dimension for the SSA955 are available in data sheet CE1N2700en.

