

Synco™ 700

Central control unit

RMB795B

for room controllers and room thermostats

- **10 independent room groups**
- **Freely programmable controller, for optimum adaption to the relevant plant type**
- **Modular extensions**
- **Menu-guided operation with separate operating unit (plug-in type or detached)**
- **KNX bus connection for operation and process information**

Use

The central control unit RMB795B provides centralized operation of room groups using room temperature controllers with adjustable scheduler, calendar, and special day programs, setpoint preselections and trend functions and collecting and forwarding of request signals to the primary side. The RMB795B central control unit is operated via a plug-in type or detached operator unit.

Together with the room controllers RXB/RXL and the room thermostats RDG/RDF/RDU the following additional functions are possible: Acquisition of the highest/lowest temperature and device supervision.

Function

Time switch	<ul style="list-style-type: none">• Yearly time switch with automatic summer/winter changeover.
Room groups	<ul style="list-style-type: none">• Per RMB795B central control unit up to 10 individual room groups can be configured.• A room group operates room temperature controllers with the same:<ul style="list-style-type: none">– Room operating modes– Room setpoints– Setpoint adjustments (summer/winter compensation)– Emergency modes.• Each room group has its own 7-day program (6 switching points per day); time switch entries can be copied.• Each room group with its own calendar (16 programmable periods) can also act on several time switches or room groups.
Heating and cooling demand	<p>The control unit can receive heating/cooling requests from any KNX room temperature controllers out of the rooms. From these signals a total demand is calculated which is being forwarded to any KNX primary controllers. Non-communicative primary controllers can also be controlled via 0...10V signal and/or relay.</p>
Universal inputs	<p>6 universal inputs for:</p> <ul style="list-style-type: none">• Passive or active analog input signals of various measured variables (°C, %, g/kg, kJ/kg, W/m², bar, mbar, m/s, Pa, and ppm).• Digital input signals (potential-free contacts)• The input signals can be received from the bus or sent over the bus.
Data acquisition	<p>Pulse meters/counters (for display only, not for billing purposes). Four meters are available to acquire consumption data. Pulses from gas, hot water, cold water and electricity meters are processed. Adjustable units: (Wh, kWh, MWh, kJ, MJ, GJ, ml, l, m³, heating cost units, BTU, no unit).</p> <p>Trend data display 4 independent trend channels are available to record measured values by time. In addition to local inputs on the unit, room temperatures and outside temperature can also be recorded via KNX bus.</p>
Logic functions	<p>10 logic function blocks can be freely configured to process multiple logically linked universal input variables.</p> <ul style="list-style-type: none">• Configurable logic functions.• Adjustable switch-on and switch-off delay and minimum switch-on and switch-off time.• Operating switch (auto, off, on), configurable for manual control.
Switching and monitoring functions	<ul style="list-style-type: none">• Fault indication with red LED, acknowledgement with button. Two relay outputs can be configured as fault relays; ten universal inputs as fault status inputs.• If the room temperature controllers are used with a 2-pipe system heating/cooling, the central control unit RMB795B notifies the room temperature controllers via a digital signal or over the bus of the changeover signal "heating/cooling".

Functions with universal modules	<ul style="list-style-type: none"> • Additional inputs and outputs to extend the functionality of the central control unit RMB795B (e.g. fault status messages, etc.). • Can be extended using a universal module RMZ785 and two universal modules RMZ787.
Bus functions	<ul style="list-style-type: none"> • Time synchronization. • Passing on and adoption of outside temperature signal. • Sending or receiving the yearly time switch schedule (clock, weekday, date, summer/winter changeover) to another unit. • Sending of the input and output signals over the bus • Receiving of the input signals from the bus
Service and operating functions	<ul style="list-style-type: none"> • Outside temperature simulation. • Wiring test. • Data backup. • Display of setpoints, actual values.

Additional functions with RXB/RXL and RDG/RDF/RDU (KNX LTE mode)

Reference rooms	1 to 3 specially selected individual rooms can be defined as reference rooms used to calculate the "Night cooling" function. The temperatures of the reference rooms can be displayed for each room group.
Highest / lowest room temperature	The highest and lowest current room temperature for each room group can be displayed. This provides an overview of temperature distribution in a room group.
Operation of RXB/RXL room controller	The function "Operate RXB/RXL" reads and writes various RXB/RXL data points. These are selected values such as room number, actual values, setpoints, operating mode, and current heat and refrigeration requests. The data points displayed depend on the type of RXB/RXL room controller and its application.
Switching and monitoring functions	<ul style="list-style-type: none"> • Fire alarm off: In an emergency, the room controllers or room thermostats assigned to a room group can be switched off via input signal. • Smoke extraction: A room group can be switched to "Smoke extraction" mode via 1 or 2 input signals. • Device supervision checks the connected room controllers or room thermostats for each room group and detects failure of one or several units.
Bus functions	<ul style="list-style-type: none"> • The room operating unit QAW740 can be assigned to one room group. • Indication of fault status messages from other units on the bus. • Common fault status message from all units on the bus to a fault status relay.

Types

Central control unit	Product number	Universal inputs	Positioning outputs	Switching outputs	Default languages
	RMB795B-1	6	2	4	de, fr, it, es, pt
	RMB795B-2	6	2	4	de, fr, nl, en
	RMB795B-3	6	2	4	da, fi, no, sv
	RMB795B-4	6	2	4	cs, sk, pl, hu, ru, bg
	RMB795B-5	6	2	4	ro, sl, sr, hr, el, tr
	RMB795B-6	6	2	4	zh

Accessories	Name	Product number	Data Sheet
Operator/service units	Operator unit, plug-in type	RMZ790	N3111
	Operator unit, detached	RMZ791	N3112
	Service tool	OCI700.1	N5655
Extension modules	Universal module with universal inputs	RMZ785	N3146
	Universal module with 4 universal inputs and 4 relay outputs	RMZ787	N3146
	Module connector for detached option modules	RMZ780	N3138

Ordering and delivery

When ordering, provide both name and type designation of the controller, for example: Central control unit **RMB795B-1**.

The devices listed under "Accessories" must be ordered as separate items.

Equipment combinations

Possible equipment combinations are available in the "Synco™700 product range overview".

Product documentation

Name	Ordering number
Synco™700 product range overview	CE1N3110en
Basic documentation, detailed description of all functions	CE1P3122en
Installation instructions G3151: RMB795, RMS705B, RMU7..B	74 319 0731 0
Operating instructions (de, fr, it, es) B3121x1	74 319 0461 0
Operating instructions (de, fr, nl, en) B3121x2	74 319 0462 0
Operating instructions (da, fi, sv) B3121x3	74 319 0463 0
Operating instructions (cs, pl, sk, hu) B3121x4	74 319 0464 0
Operating instructions (ro, sl, sr, hr) B3121x5	74 319 0465 0
Data sheet "KNX bus"	CE1N3127en
Synco KNX s-mode data points	CE1Y3110en
Basic documentation "Communication via KNX bus" for Synco units and devices	CE1P3127en
Declaration of conformity (CE)	CE1T3110xx
Environmental declaration	CE1E3110en01

Technical design

The central control unit RMB795B with the aid of operator unit RMZ790 or RMZ791 allow free configuration of applications.
For operating actions of the functions, see Basic documentation CE1P3122en.

Mechanical design

The unit consists of a device insert and terminal base. The terminal base has two terminal levels as well as connection elements (electrical and mechanical) for one extension module. The device insert with its printed circuit boards is attached to the terminal base.

The device can be mounted on a top hat rail (EN 60 715-TH35-7.5), or directly on a wall.

Operation takes place either with a plug-in type or detached operator unit (refer to section "Accessories").

Operating, display and connecting elements

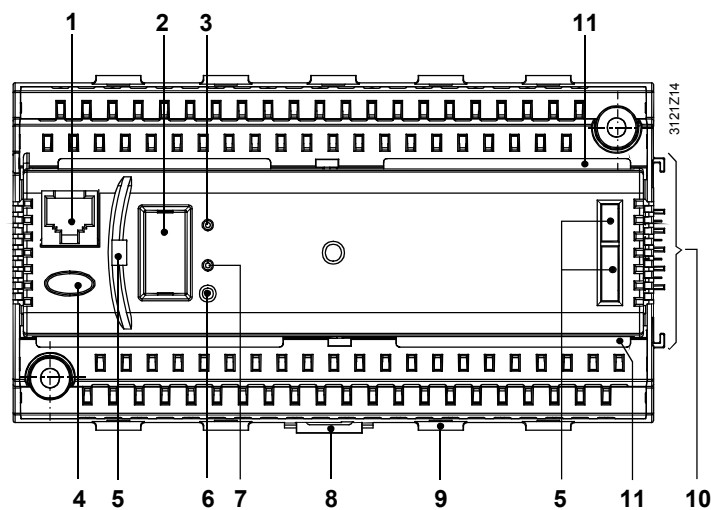

Key

- 1 Connection for the service tool (RJ45 connector)
- 2 Removable cover with connection for the operator unit
- 3 LED "RUN" for indicating the device's operating state:
LED lit: Supply voltage, no fault in application and periphery
LED off: No power or incorrect use / faulty peripheral devices
- 4 Button "↓" with LED (red) to indicate fault status message and their acknowledgement:
LED flashes: Fault status message, ready to acknowledge
LED lit: Fault status message pending, but not yet reset
LED off: No fault status message
Press button: Acknowledge fault or reset.
- 5 Openings for plug-in type operator unit RMZ790
- 6 Programming button "Prog": Learning button for switching between normal mode and addressing mode to assume the physical device address (tool required)
- 7 Programming LED "Prog" to display normal mode (LED off) or addressing mode (LED on) to assume the physical device address.
- 8 Moveable element to fit the controller on a top hat rail
- 9 Fastening strap for the cable tie (cable strain relief)
- 10 Electrical and mechanical connection elements for the extension module
- 11 Rest for terminal cover

Engineering notes



- AC 24 V voltage is required to power the device. SELV/PELV requirements (safety extra low-voltage) must be met.
- Safety isolating transformers featuring double insulation as per EN 60742 or EN 61558-2-6 must be used; they must be suited for 100% duty.
- Fuses, switches, wiring, and earthing must comply with local regulations for electrical installations.
- Avoid running sensor wires parallel to mains carrying wires powering fans, actuators, pumps, etc.
- The unit allows for using one RMZ785 extension module as well as two RMZ787 extension modules.

Mounting and installation notes

- The unit and the extension modules are designed for:
 - Mounting in a standard cabinet as per DIN 43880.
 - Wall mounting on an existing top hat rail (EN 50022-35x7.5).
 - Wall mounting using two fixing screws.
 - Flush-panel mounting.
- Mounting in wet or damp spaces is not allowed; observe all permissible environmental conditions.
- If the controller is not operated inside a control panel, use the detached operator unit RMZ791 in place of the plug-in unit RMZ790.
- Disconnect the system from power prior to mounting and installing the unit.
- **Do not remove the controller insert from the terminal base!**
- If extension modules are used, attach them to the right side of the unit in the correct order as per the internal configuration.
- The extension modules require no wiring between themselves or to the unit; electrical connections are made automatically when attaching the modules. If not all extension modules can be arranged side by side, the first of the detached modules must be connected to the last previous module or to the unit using the RMZ780 module connector. In this case, the cumulated cable length is max. 10 m.
- All connection terminals for protective extra low-voltage (sensors, data bus) are located in the upper half of the unit, those for mains voltage (actuators and pumps) in the lower half.
- Each terminal (spring cage terminal) can only accommodate one solid wire or one stranded wire. For connections, strip the cables to 7 to 8 mm. To introduce the cables into the spring cage terminals and to remove them, a screw driver size 0 or 1 is required. Cable strain relief can be provided with the help of the fastening strap for cable ties.
- The unit mounted on a top hat rail together with modules can be removed from the rail only after the module directly attached to the unit has been removed.
- The controller is supplied complete with installation instructions.

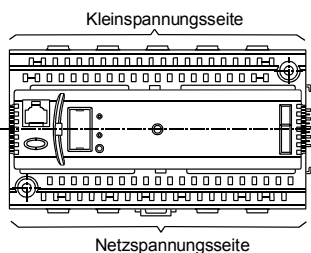

No internal line protection for supply lines to external consumers.

Risk of fire and injury due to short-circuits!

Adapt the line diameters as per local regulations to the rated value of the installed overcurrent protection device.

Commissioning

- Configuration and parameters of the application programmed in the unit can be changed locally using the operator unit RMZ790 or RMZ791, or using a service tool online or offline by trained staff authorized accordingly (access rights).
- During commissioning, the application is deactivated and the outputs are in a defined off state. As a result, no process and alarm signals are sent to the bus.
- After completing configuration, the unit automatically restarts.
- When exiting the commissioning pages, the peripheral devices connected to the universal inputs (including the extension modules) are automatically tested and identified. If a peripheral device is missing, an error message is generated.
- The operator unit can be removed and plugged in or connected during operation.
- If adaptations to specific plants are required, they must be recorded and the documentation stored inside the control panel.
- Procedures for commissioning and initial start are described in the installation instructions.

General notes

Maintenance

The central control unit RMB795B is maintenance free (no battery changes, no fuses). The housing may only be cleaned with a dry towel.

Repair

The central control unit cannot be repaired on site.

Disposal



The devices are considered electronics devices for disposal in term of European Directive 2012/19/EU and may not be disposed of as domestic waste.

- Dispose of the device via the channels provided for this purpose
- Comply with all local and currently applicable laws and regulations.

Technical data

Power supply (G, G0)	Rated voltage range	AC 24 V \pm 20 % (SELV) HD 384
	Safety extra low-voltage (SELV) / protective extra low-voltage (PELV) as per the requirements placed on external safety transformers (100% duty, max. 320 VA) as per	EN 60742 / EN 61558-2-6
	Frequency	50/60 Hz
	Power consumption (excl. modules)	Max. 12 VA
	External supply line protection	Fuse slow max. 10 A or Circuit breaker max. 13 A Characteristic B, C, D according to EN 60898 or Power source with current limitation of max. 10 A
Functional data	Clock reserve	48 hours typical, min. 12 hours
Universal inputs	Number	See "Type summary"
Measured value inputs (X...)	Sensors	
	Passive	LG-Ni 1000, T1, Pt 1000 2x LG-Ni 1000 (averaging) DC 0...10 V
Status inputs (X...)	Active	
	Contact sensing	
	Voltage	DC 15 V
	Current	5 mA
	Requirements for status contacts	
	Signal coupling	Potential-free
	Type of contact	Maintained contact
	Insulating strength against mains potential	AC 3750 V as per EN 60730
	Requirements for pulse contacts	Screened cables recommended
	Signal coupling	Potential-free
	Type of contact	Pulse contact
	Mechanical transmitter (reed contract)	
Maximum pulse frequency	25 Hz	
Minimum pulse length	20 ms (with max. 10 ms bounce length)	
Electronic transmitter		
Maximum pulse frequency	100 Hz	
Minimum pulse length	5 ms	
Insulating strength against mains potential	AC 3750 V as per EN 60730	
Perm. resistance	Contacts closed	Max. 200 Ω
	Contacts open	Min. 50 k Ω
Outputs	Number of positioning and switching outputs	See "Type summary"
Positioning outputs Y...	Output voltage	DC 0...10 V
	Output current	\pm 1 mA
	Max. load	Continuous short-circuit
	External supply line protection	see section power supply
	Relay contacts	
	Switching current	Max. AC 250 V Min. AC 19 V
	Load AC	Max. 4 A res., 3 A ind. (cos φ = 0.6)
	At 250 V	Min. 5 mA
	At 19 V	Min. 20 mA
	Switch-on current	Max. 10 A (1 s).
	Contact life at AC 250 V	Guide values:
	At 0.1 A res.	2 x 10 ⁷ cycles
At 0.5 A res.	4 x 10 ⁶ cycles (N. O.) 2 x 10 ⁶ cycles (changeover)	
At 4 A res.	3 x 10 ⁵ cycles (N.O.) 1 x 10 ⁵ cycles (changeover)	
Red. Factor at ind. (cos φ = 0,6).	0.85	
Insulating strength	Between relay contacts and system electronics (reinforced insulation)	AC 3750 V as per EN 60730-1
	Between neighboring relay contacts (operational insulation) Q1 \leftrightarrow Q2	AC 1250 V as per EN 60730-1
	Between relay groups (reinforced insulation) (Q1, Q2) \leftrightarrow Q3 \leftrightarrow Q5	AC 3750 V as per EN 60730-1
	Voltage	AC 24 V
	Current	Max. 4 A
External supply line protection	see section power supply	
Supply external devices (G1)		



Switching outputs
AC 230 V (Q1x...Q5x)

Interfaces	KNX bus	
	Interface type	KNX TP1
	Bus loading figure	2.5
	Bus power supply, can be switched off	25 mA
	Power failure of short duration as per EN 61000-4-11	100 ms with one extension module
	Extension bus	
	Connector specification	4 contacts SELV/PELV
	Number of plug-in cycles	Max. 10
	Service tool connection facility	RJ45 connector
Permissible cable lengths	For passive measuring and positioning signals	(Measuring errors can be corrected under the menu "Settings/inputs")
	Type of signal	
	LG-Ni 1000, T1	Max. 300 m
	Pt1000	Max. 300 m
	Contact sensing (status and pulse contacts)	Max. 300 m
	For DC 0...10 V measuring and control signals	See data sheet of the signaling device
	For KNX bus	Max. 700 m
	Cable type	2-core without screening, twisted pair
	for switching outputs (Q1x...Q5x)	Max. 300 m
Electrical connections	Connection terminals	Spring cage terminals
	For wires	Dia. 0.6 mm ... 2.5 mm ²
	For stranded wires without ferrules	0.25 ... 2.5 mm ²
	For stranded wires with ferrules	0.25 ... 1.5 mm ²
	KNX bus connection	Connections not interchangeable
Protective data	Degree of protection of housing to IEC 60 529	IP 20 (when mounted)
	Safety class to EN 60 730	Device suited for use with equipment of safety class II
Environmental conditions	Operation to	IEC 60721-3-3
	Climatic conditions	Class 3K5
	Temperature (housing and electronics)	0...50 °C
	Humidity	5...95% r.h. (non-condensing)
	Mechanical conditions	Class 3M2
	Transport to	IEC 60721-3-2
	Climatic conditions	Class 2K3
	Temperature	-25...+70 °C
	Humidity	<95% r.h.
	Mechanical conditions	Class 2M2
Classifications as per EN 60730	Mode of operation, automatic controls	Type 1B
	Degree of contamination, control environment	2
	Software class	A
	Rated surge voltage	4000 V
	Temperature for ball-pressure test of housing	125 °C
Materials and colors	terminal base	Polycarbonate, RAL 7035 (light-grey)
	Controller insert	Polycarbonate, RAL 7035 (light-grey)
	Packaging	Corrugated cardboard
Standards, regulations	EU Conformity (CE)	CE1T3110xx *)
	RCM conformity	CE1T3110en_C1 *)
	The product environmental declaration CE1E3110en02 *) contains data on environmentally compatible product design and assessments (RoHS compliance, materials composition, packaging, environmental benefit, disposal).	
Weight	Excl. packaging	0.49 kg

*) The documents can be downloaded from <http://siemens.com/bt/download>.

Connection diagrams

Internal diagrams

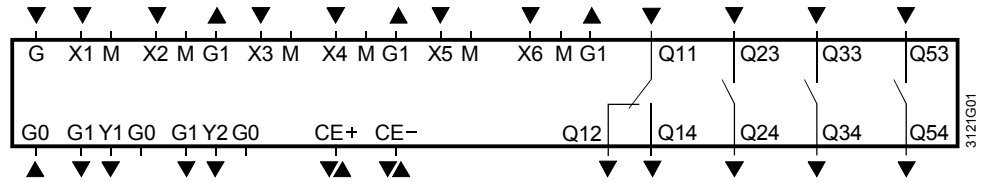

Key

- G, G0 AC 24 V rated voltage
- G1 Output voltage AC 24 V to power external, active unit
- M Measuring neutral for signal input
- G0 System neutral for signal output
- X1...X6 Universal signal inputs for LG-Ni 1000, 2x LG-Ni 1000 (averaging), T1, Pt 1000, DC 0...10 V, pulse, contact sensing (potential-free)
- Y1...Y2 Control or status outputs, analog DC 0...10 V
- Q... Potential-free relay outputs for AC 24...230 V.
- CE+ KNX bus data line, positive
- CE- KNX bus data line, negative

Notes

Each terminal (spring cage terminal) can only accommodate one solid wire or one stranded wire. Double terminals are internally interconnected.

Connection diagrams

Examples:

Connections on the measuring side

Connection diagram 1: Measuring section with passive sensor

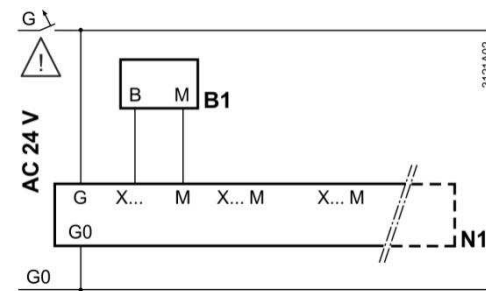

For external supply line protection, see specification in technical data.

Connection diagram 2: Measuring section with active sensor

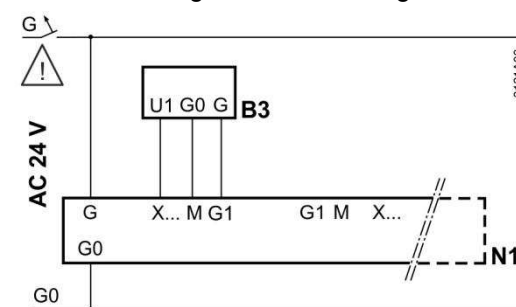

For external supply line protection, see specification in technical data.

Connections on the control and monitoring side

Connection diagram 3: Multiple use sensors (B1, N2) and output of the resulting operating mode from a room group to other units (N3) – For required internal configuration, see basic document CE1P3122en –, "Digital input" (S6).

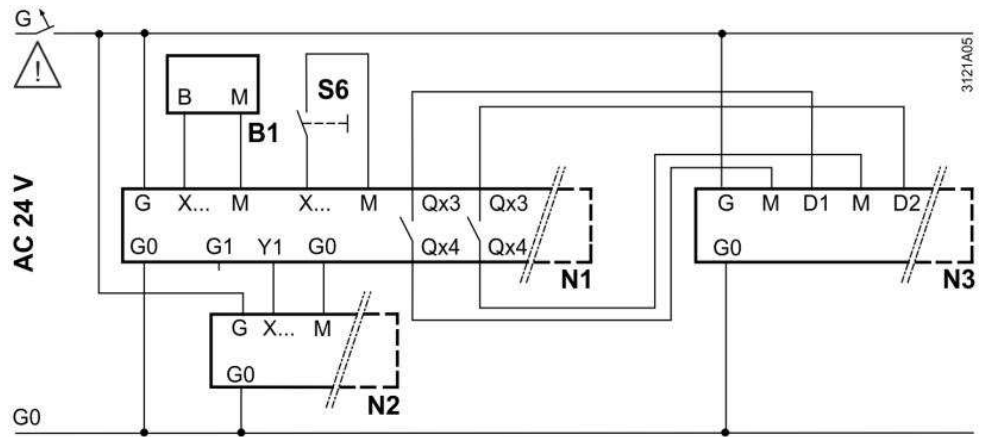

For external supply line protection, see specification in technical data.

Key to connection diagrams 1 through 3

N1	Central control unit RMB795B	B1	Duct temperature sensor QAM21.20...
N2	Universal controller RLU220	B3	Duct temperature sensor QAM2161.040
N3	Universal controller RLU232	S6	HC operating mode changeover, manual

Dimensions

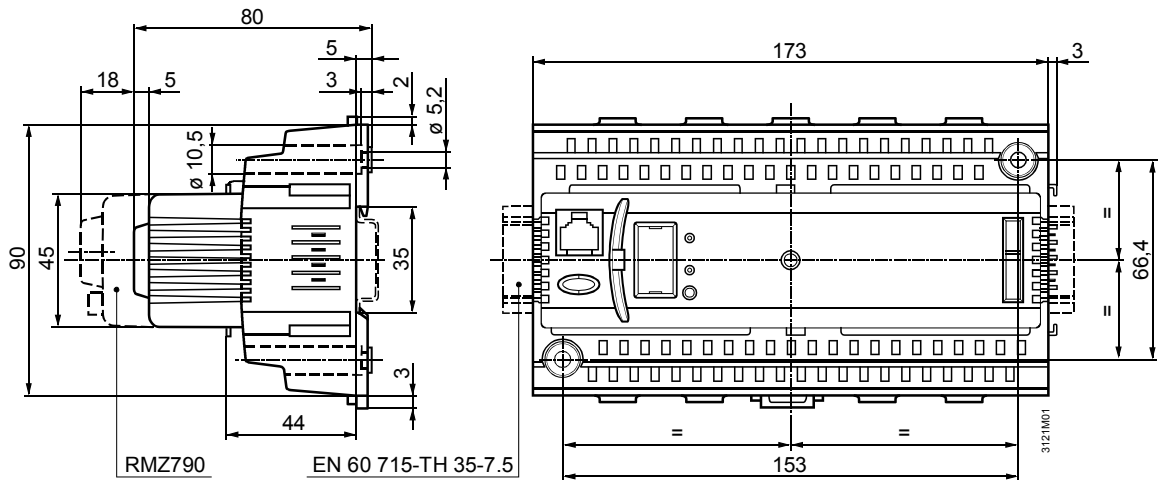

Dimensions in mm