

RXB

Room controller

RXB39.1

Communicating room controller
for fan-coil applications FC-13

The RXB39.1 room controller is used for temperature control in individual rooms.

- For 2-pipe or 4-pipe fan-coil systems, with or without change-over
- ECM fan support
- PI control
- KNX bus communication
- Integration into the Desigo building automation and control system via PX KNX
- DC 0...10 V control of valve actuators, fan, and electric heating coil
- Volt-free relay contacts for release of the fan and the electric heating coil
- Commissioning with ETS Professional, "HandyTool" or Synco ACS
- AC 230 V operating voltage
- Pluggable screw terminals

Use

The RXB39.1 room controller is optimized for control of fan-coil systems in individual rooms.

The function of each controller is determined by the application software.

The controllers are delivered with a fixed set of applications. The relevant application is selected and activated during commissioning using one of the following tools:

- ETS Professional
- "HandyTool" (the QAX34.3 room unit includes a tool function which allows you to set the parameters of the connected RXB controller)
- Synco ACS

Functions

The room controller functions are determined by the selected application, its parameters, and by the input/output configuration.

For details, refer to the FNC description of functions, document CM110385.

When RXB controllers are integrated into a building automation and control system, or into a Synco system, additional functions become available such as time scheduling, central control of setpoints, etc.

Applications

The following applications are available for the RXB39.1 room controller:

Application group (type)	Fan-coil applications
FC-13	ECM fan application

Note Only one application at a time can be activated with the tool (ETS Professional, "HandyTool" or Synco ACS).

Ordering

Product number	Stock number	Designation
RXB39.1/FC-13	S55373-C121	Room controller
RXZ30.1	--	Terminal covers (to be ordered separately)

Equipment combinations

The RXB39.1 room controller is compatible with field devices from Siemens Building Technologies.

For details, refer to the Desigo RX hardware overview, CA2N3804.

The RXB39.1 controller consists of a housing base, a housing cover and the printed circuit board with connection terminals. The room controller also has a tool socket, a service LED and a programming button.

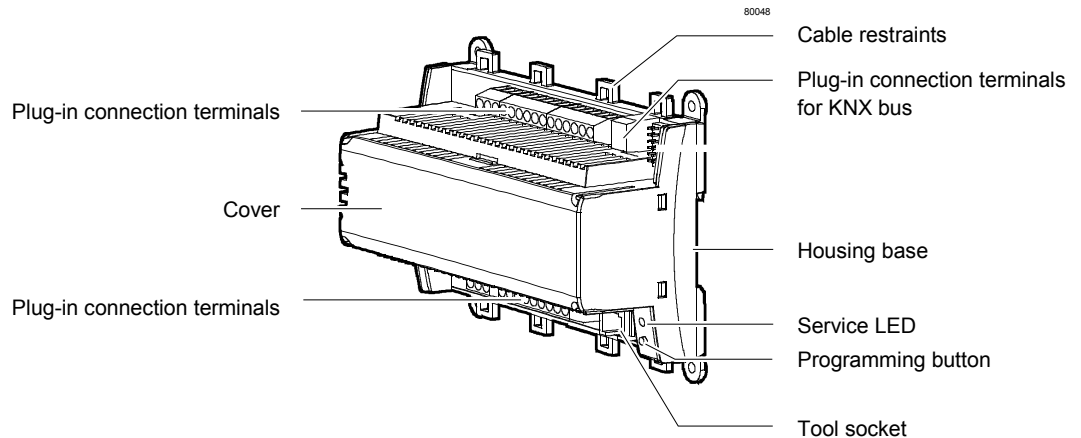

Service LED

The Service LED shows the operational status of the room controller as follows:

Green, flashing	Normal operation.
Red, ON	<ul style="list-style-type: none"> • Programming mode for address assignment (ETS / ACS). • Fault
Orange / green, flashing	<ul style="list-style-type: none"> • Startup phase. • No application selected. • Loading. <ul style="list-style-type: none"> – Download from ACS. – Room unit QAX34.3 in HandyTool mode.
OFF	<ul style="list-style-type: none"> • No supply voltage • Fault
Other patterns	<p>After switching on the operating voltage, the service LED flashes in different patterns for 3 to 5 seconds.</p> <p><i>If other patterns appear during normal operation, this indicates an error.</i></p>

Programming button

The programming button is used to identify the room controller in the commissioning phase.

Pressing this button causes the red service LED to light up and remain on until identification of the controller is complete.

Once the programming button has been pressed, the tool overwrites the hardware address in the room controller.



Note!

If there are no terminal covers fitted, the programming button may be operated only by a qualified electrician.

The adjacent terminal may be a live mains voltage conductor.

Terminal cover

Terminal covers (RXZ30.1) are available as an option, to protect the connection terminals from physical contact and dirt. The service LED remains visible when the terminal covers are in place, and the programming button can be operated with a pointed implement. The cable is connected to the room controller by breaking out the perforated cable entry guide.

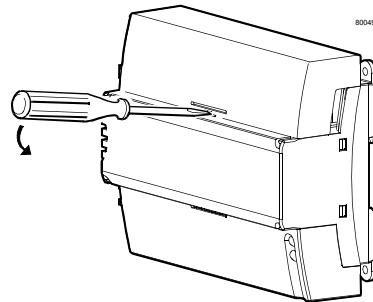

Removing the terminal cover

Label

Bar code, Code 39 (ID number)

Protection standard

Temperature range (0 ... 50 °C)

Test date, series (Z, A, B, C...)

Serial No.

Observe the warning notes in this data sheet

Identification number (unique serial number)

Definitively loaded application

Location

SIEMENS
 RXL 39, NFC-13
 S55373-C122
 Origin: Switzerland
 Siemens Switzerland Ltd
 AC 230V~, 12VA
 50/60Hz T50 IP20(30)
 121211Z 550
 Copper conductors only
 Torque: 0,5Nm
CAUTION!
 Risk of electric shock. Multiple disconnect may be provided.

AC 230V~
 AC 24 ... 230V~
 10A 5/40A

QAX...
 2 1 4 3
 29 30 31 32

ID: 001086169900 Hex
 Appl.:
 Loc.:

- Note Options for use of the labeling fields “Appl.” and “Loc.”:
- Handwritten identification of the location and the activated application group.

Connection terminals

All connection terminals are detachable plug-in screw-terminals. To avoid incorrect wiring, terminals which can be connected to AC 230 V (relay outputs) are physically separated from the other terminals.



Note!

The cable restraints on the housing base *must* be used for the connections to terminals 19 ... 27 (AC 230 V). The conductors must be secured with cable ties (see diagram).

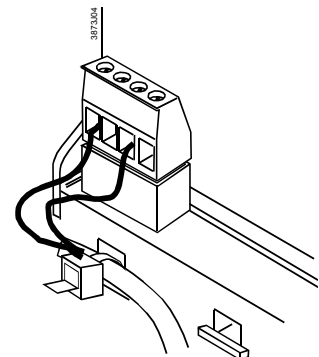

Warning!

Ensure that the power is off before inserting or removing plug-in terminals connected to a mains voltage.

Communication

The RXB39.1 room controller communicates with other devices via the following interfaces:

- PPS2 interface (proprietary) for the exchange of data with the room units
- KNX bus (terminals CE+ and CE-) for communication with:
 - PX/KNX interface (to Desigo Insight)
 - Interface OCI700 (to Synco)
 - Other RXB controllers
 - Other KNX devices (e.g. field devices)

Connecting the tool

To facilitate commissioning, the tools ETS / ACS can be connected at three different points (marked **A**) in the diagram in the plant:

- to the KNX bus cable at any point
- to the RXB39.1 controller (RJ45 tool socket)
- to the room unit (RJ45 tool socket)

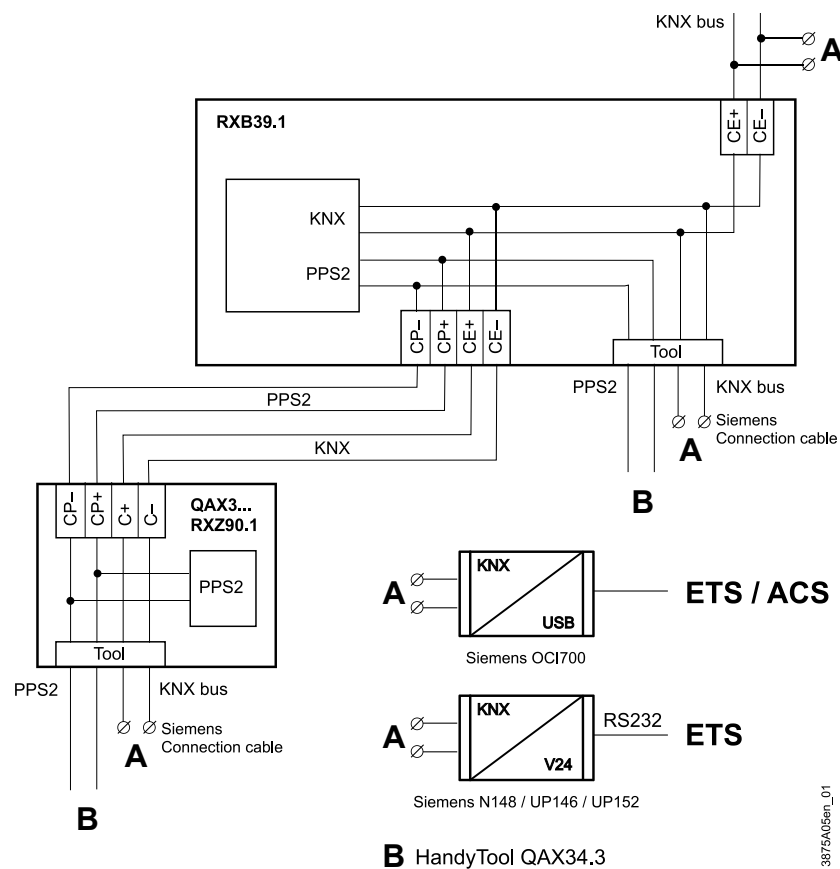

Notes

- The tool socket is a proprietary socket.
A Siemens connecting cable must be used (e.g. PXA-C1).
- **When connected to Ethernet, the device on the other end may be damaged!**
- The tools ETS and ACS, even if connected to a tool socket, require an interface:
 - RS232-KNX interface (ETS)
 - USB-KNX / EIB interface OCI700 (ETS, ACS).
- The "HandyTool" is connected to the tool socket of the room controller or to the tool socket of the room unit (QAX..., RXZ90.1) (**B**).
- If you use OCI700 as an interface, it is connected to the service plug of the controller or of the room unit.
As long as the OCI700 is connected to the service plug, it must be supplied by the computer via the USB interface. Otherwise the LCD display of the room unit will turn dark and the controller will switch to addressing mode.



Caution!

Disposal



The device is classified as waste electronic equipment in terms of the European Directive 2002/96/EC (WEEE) and should not be disposed of as unsorted municipal waste.

The relevant national legal rules are to be adhered to.

Regarding disposal, use the systems setup for collecting electronic waste.

Observe all local and applicable laws.

Engineering

KNX bus

Topology	Tree, line, or star NO closed loops
Cable length	Max. 1000 m (sum of all cables of a line (for details refer to document CM110381))
Cable type	E.g. YCYM 2 x 2 x 0.8 mm
Number of RXB Controllers per Network	Max. 45
Bus supply	Up to 45 RXB-controllers: 5WG1 125-1AB12
Bus terminator	Not required

AC 230 V supply cables

- The RXB39.1 room controller operates with a mains supply voltage of AC 230 V.
- The sizing and fuse protection of the power supply cables depend on the total load and on local regulations.
- If serial wiring is applied on the terminal block L / N, the connection will be interrupted if the block is removed from the controller (the jumpers 19-19 and 21-21 are on the PCB, not in the block, see terminal diagrams on page 10)
- Different phases may be connected to the terminals 21 (L), 23 (Q13) and 26 (Q33).
- All AC 230 V conductors must be secured with cable ties.

Volt-free relay outputs AC 230 V

- The volt-free releasing relay output for the fan allows the switching of a load up to AC 250 V, 5(4) A.
- The volt-free releasing relay output for the heating coil switches a resistive load up to 1.8 kW, max. 10 A.
- The circuits must be externally fused (≤ 10 A) as there are no internal fuses.
- The cables connected to the room controller must be secured with cable ties.

DC 0...10 V outputs

– Valve actuators

- The DC 0 ... 10 V control outputs YC1, YC2 deliver max 1.5 mA.
- The AC 24 V supply output G (next to YC2) delivers max. 6 VA.

– Fan control

- The DC 0 ... 10 V control output YC3 delivers max 1.5 mA.

AC 24 V supply for field devices (G)

- The controlled devices (valve and damper actuators) receive their power directly from the room controller. This means that a separate AC 24 V supply is only necessary for the field devices require more than a total of 6 VA.

Mounting

The room controllers can be mounted in any orientation, and fixed as follows:

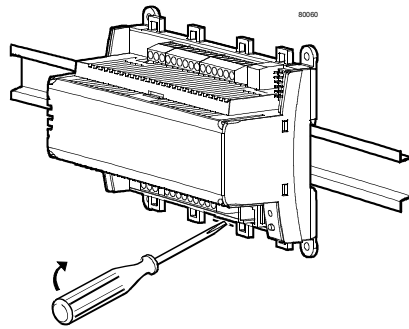

Rail mounting

The housing base is designed for snap-mounting on DIN rails, type EN50022-35x7.5 (can be released with a screwdriver)

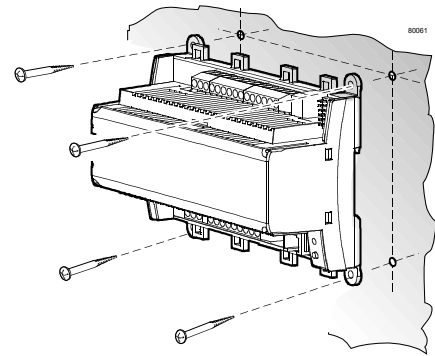

Surface mounting

There are four drill holes for screw-mounting (see "Dimensions" for drilling template). The housing base is fitted with raised supports.

When mounting note the following:

- The controller should not be freely accessible after mounting. It must be mounted in a cabinet or behind a cover that can only be opened / removed with a key or a tool.
- Ensure adequate air circulation to dissipate heat generated during operation.
- Easy access is required for service personnel
- Local installation regulations must be observed.

Mounting instructions and a drilling template are printed on the controller packaging.

Commissioning

The RXB39.1 room controller is commissioned with one of the following tools:

- ETS Professional
- Synco ACS
- "HandyTool" via PPS2

Labeling

The definitive application and the controller's location are handwritten in the labeling fields "Appl." and "Loc" in the commissioning stage.

Function test

A special test mode (ETS and HandyTool) is available for operation of the outputs and interrogation of the inputs.

Technical data

⚠ Power supply	Operating voltage	AC 230 V +/-10 %
	Rated voltage	AC 230 V
	Frequency	50/60 Hz
	Power consumption with connected field devices	Max. 12 VA
	Internal fuse	Thermal, non-resetting
Operating data	Control algorithm	PI
Inputs (SELV)		
Signal inputs D1 ... D4 (for volt-free contacts)	Quantity	4
	Contact voltage	DC 16 V
	Contact current	DC 5 mA
	Contact transfer resistance	Max. 100 Ω
	Contact insulation resistance	Min. 50 kΩ
Measured value input B1	Switch time:	min. 20ms "ON", min. 20ms "OFF"
	Compatible temperature sensors	LG-Ni 1000
	Quantity	2
	Measuring range	0 ... 50 °C
	Sensor current	0.5 mA
	Resolution	0.1 K
	Measuring error at 25 °C sensor temp. (without cable)	max. 0.5 K
Outputs (SELV)		
DC 0 ... 10 V YC1, YC2, YC3	Quantity	3
	Resolution	3 mV
	Accuracy	100 mV
	Output current	Max. 1.5 mA
Supply output G (SELV)	Voltage / Max. load	AC 24 V / Max. 6 VA
⚠ Relay outputs		
Q34 (fan release)	Quantity	1 (N/O contact)
	Relay type	Monostable
	Contact rating with AC voltage	
	Switching voltage	Max. AC 250 V, min. AC 19 V
	Nominal current, resistive/inductive	Max. AC 5(4) A (cos φ = 0.6)
	Making current 200 ms half-time	Max. 20 A
	Switching current at AC 19 V	Min. AC 10 mA
	Contact rating with DC voltage	
	Switching voltage	Max. DC 250 V, min. DC 5 V
	Switching current at DC 5 V	Min. DC 100 mA
	Switching capacity	Max. 20 W
Inductive load L/R	Max. 7 ms	
	External fuse (essential!)	Max. 10 A
Q14 (heater release)	Quantity	1 (N/O contact)
	Relay type	Monostable
	Contact rating with AC voltage	
	Max. admissible load (resistive only)	Max. 1.8 kW
	External fuse (essential)	Max. 10 A
Ports/interfaces		
Interface to room unit	Number of room units connectable	1
	Interface type	for room unit for ETS / ACS
	PPS2 baud rate	4.8 kbit/s
	Baud rate on the KNX bus	9.6 kbit/s
KNX bus	Interface type	Electrically isolated
	Bus current	5 mA
	Baud rate bus	9.6 kbit/s
	Bus topology	Refer to Engineering, page 6

Cable connections	Connection terminals for signals and power supply	Solid or stranded conductors 0.25 ... 2.5 mm ² or 2 x 1.5 mm ²			
	KNX bus connection terminals	Solid or stranded conductors 2 x max. 1.0 mm ² e.g. YCYM 2x2x0.8			
Housing protection standard	Single cable lengths	For field devices, see also the RXB / RXL installation guide, CA110381			
	Signal inputs D1 ... D4	Max. 100 m with diameters ≥ 0.6 mm			
	Measured value input B1, B2	Max. 100 m			
	0 ... 10 V outputs YC1, YC2 (valve actuators)	Max. 100 m where A ≥ 1.5 mm ²			
	0 ... 10 V outputs YC3 (fan)	Max. 100 m where A ≥ 1.5 mm ²			
	Relay outputs Q14, Q34	Depends on load and local regulations			
	Interface to room unit	Max. 115 m where A= 0.75 mm ² (including connecting cable for tool)			
	Cable type	4-core, twisted pair, unshielded			
	KNX bus	Max. 1000 m (see Engineering, page 6)			
	Tool connecting cable	Max. 3 m			
Housing protection standard	Protection standard to EN 60529	IP30 with terminal cover fitted and wall mounted without DIN rail IP20 for all other mounting arrangements			
Protection class	Suitable for use in systems with protection class I or II				
Ambient conditions	Normal operation	Class 3K5 to IEC 60721-3-3			
	Temperature	0 ... 50 °C			
	Humidity	< 85 % r.h.			
	Transport	Class 2K3 to IEC 60721-3-2			
Industry standards	Temperature	- 25 ... 65 °C			
	Humidity	< 95 % r.h.			
	- Product standards	EN 60730			
	CE marking				
Industry standards	- EMC	2004/108/EG			
	Immunity (industrial & residential)	EN 60730-1, EN 50491-5-2, EN 50491-5-3			
	Emission (residential)	EN 60730-1, EN 50491-5-2			
	- Low Voltage Directive	2006/95/EC			
	Electrical safety	EN 60730-1			
	- RoHS	2011/65/EU			
	Techn. RoHS proof	EN 50581			
	C-Tick conformity (EMC)	AS/NZS 61000-6-3			
	Industry standards	Meets the requirements for eu.bac certification			
		See product list at: http://www.eubacert.org/licences-by-criteria.asp			
Type		License	Application		
RXB39.1		213297	Fan-Coil 2 pipes		
Industry standards			Control accuracy [K]		
			heating / cooling	0.1 / 0.1	
			Fan-Coil 2 pipes 2 wires	heating / cooling	0.2 / 0.1
			Fan-Coil 4 pipes	heating / cooling	0.2 / 0.1
Environmental compatibility	The product environmental declaration CM1E3876 contains data on RoHS compliance, materials composition, packaging, environmental benefit, disposal	ISO 14001 (Environment) ISO 9001 (Quality)			
Dimensions	See dimension diagrams				
Weight	excluding packaging	0.560 kg			
	including packaging	0.600 kg			



Connection terminals

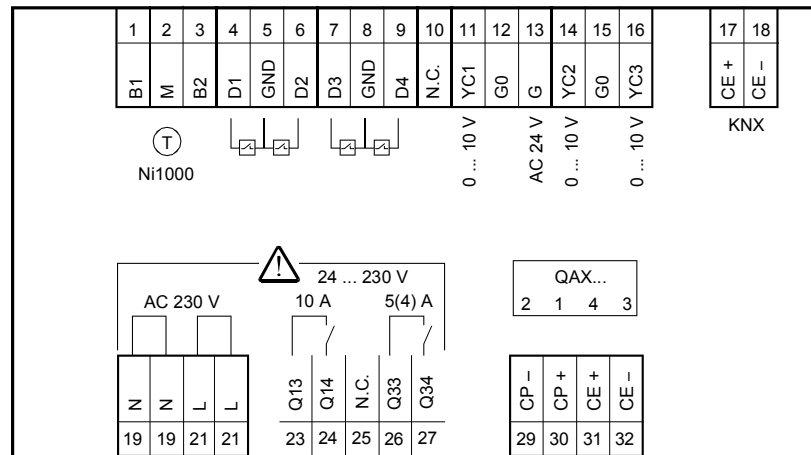

Measured value input

- B1 1 Measured value input for LG-Ni 1000 sensors
- M 2 Measured value input ground
- B2 3 Measured value input for LG-Ni 1000 sensors

Signal inputs

- D1 4 Signal input
- GND 5 Signal ground
- D2 6 Signal input
- D3 7 Signal input
- GND 8 Signal ground
- D4 9 Signal input
- N.C. 10 **Do not use this terminal as an auxiliary terminal!**

0 ... 10 V outputs

- YC1 11 0 ... 10 V Heating control signal
- G0 12 Signal ground
- G 13 AC 24 V max. 6 VA
- YC2 14 0 ... 10 V Cooling control signal (heating / cooling in case of changeover)
- G0 15 Signal ground
- YC3 16 0 ... 10 V Fan control signal

KNX bus

- CE+ 17 KNX bus
- CE- 18 KNX bus

Power supply

- N 19 Neutral conductor
- L 21 Phase conductor AC 230 V +/- 10 %

Relay outputs

- Q13 23 Feed for Q14
- Q14 24 Normally-open contact, max. AC 250 V, 1.8 kW, max. 10 A (Electric heating)
- Q33 26 Feed for Q34
- Q34 27 Normally-open contact, max. AC 250 V, 5(4) A (controlled fan)

Room unit

- CP- 29 PPS2 ground
- CP+ 30 PPS2 data
- CE+ 31 KNX bus
- CE- 32 KNX bus

Caution

- **Observe the technical data for the relay outputs: max. AC 250 V, 5 (4) A**
- **External fuse (essential!): max. 10 A**
- **Local installation regulations must be observed.**

Tool socket

Proprietary RJ45-type tool socket

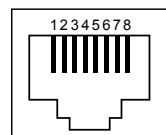

- | | | | |
|---|---------------|---|------------------|
| 1 | KNX bus (CE+) | 5 | +12VDC |
| 2 | KNX bus (CE-) | 6 | RxD |
| 3 | Not used | 7 | PPS2 (CP+) / TxD |
| 4 | Not used | 8 | PPS2 (CP-) |

Connection diagrams

Connection of field devices, room unit, KNX bus and power supply

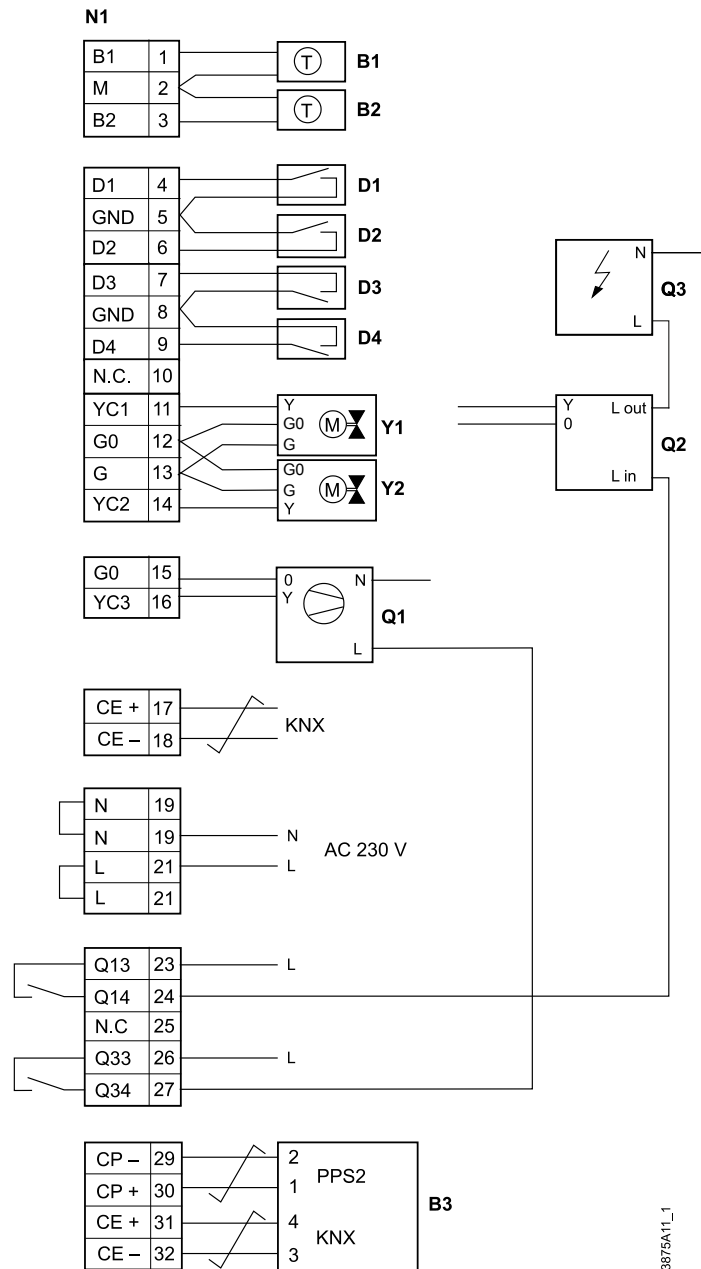

- N1 RXB39.1
 B1, B2 LG-Ni 1000 temperature sensor
 D1 ... D4 Volt-free contacts (window contact, occupancy sensor, etc.)
 Y1 0 ... 10 V valve actuator heating
 Y2 0 ... 10 V valve actuator cooling (heating / cooling in case of changeover)
 Q1 Controlled fan
 Q2 Power controller (PWM or modulating)
 e.g. SEM61.4 + SEA45.1, data sheets N5102, N4937
 Q3 Electric heating
 B3 QAX... room unit

✓ Twisted pair



Note!

For Q2 (1.8 kW max. resistive load), use additional external fuses of max. 10 A to protect the PCB tracks.

Note For information on the compatibility of field devices with the RXB39.1 room controller, refer to the RX hardware overview, CA2N3804.

Dimensions

Dimensions in mm

Without terminal covers

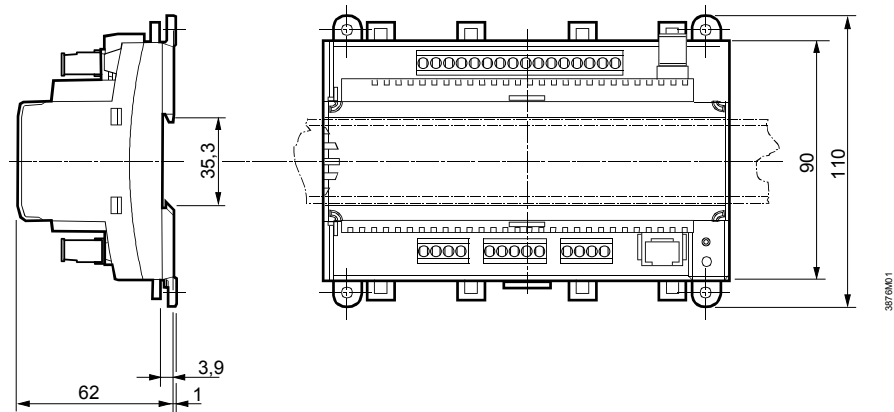

With terminal covers

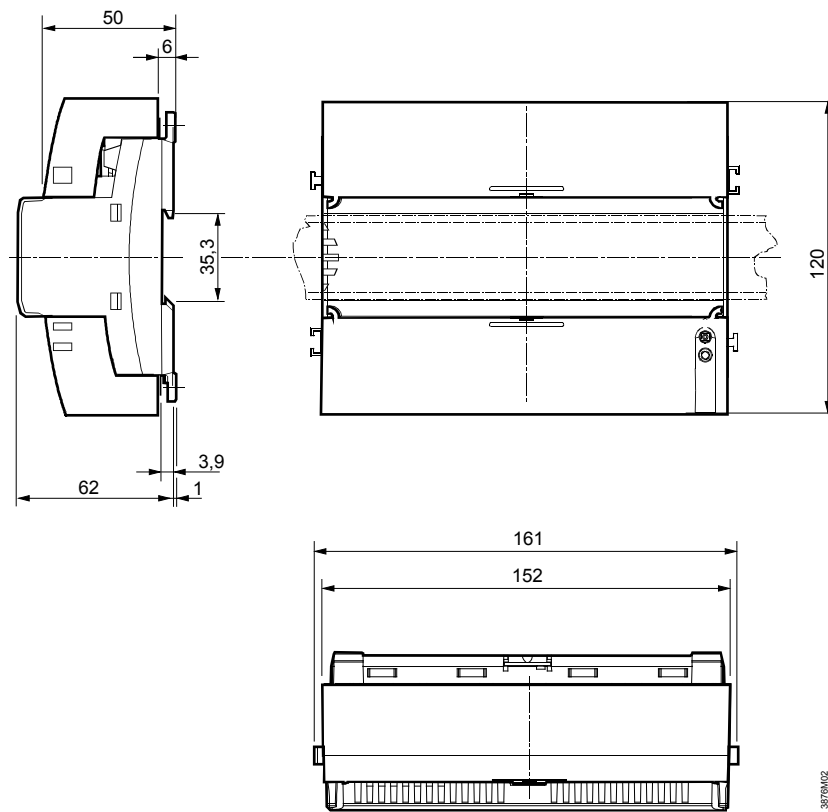

Drilling diagram

