



VAI60..



VBI60..L



VBI60..T

ACVATIX™

Open/close ball valves 2-port VAI60.. and changeover ball valves VBI60..L 3-port, PN40 VBI60..T

with internally threaded connections

- Brass UNS C35330 (DZR) ball valve body
- DN 15...50
- k_{vs} 5...96 m³/h
- Internally threaded connections Rp as per ISO 7-1
- Angle of rotation 90°
- For use with rotary actuators GQD..9A, GMA..9E with spring-return and GSD..9A, GLB..9E without spring return

Use

For use in heating, ventilating and air conditioning plants as open/close or changeover ball valve.

For closed circuits (avoid cavitation, see page 5).

Type summary

Open/close ball valves 2-port	Type		DN	k _{vs} [m ³ /h]
	Changeover ball valves 3-port (L)	Changeover ball valves 3-port (T)		
-	VBI60.15-5L	-	15	5
-	-	VBI60.15-12T		12
VAI60.15-15	-	-		15
-	VBI60.20-9L	-	20	9
-	-	VBI60.20-16T		16
VAI60.20-22	-	-		22
-	VBI60.25-9L	-	25	9
-	-	VBI60.25-16T		16
VAI60.25-22	-	-		22
-	VBI60.32-13L	-	32	13
-	-	VBI60.32-25T		25
VAI60.32-35	-	-		35
-	VBI60.40-25L	-	40	25
-	-	VBI60.40-49T		49
VAI60.40-68	-	-		68
-	VBI60.50-37L	-	50	37
-	-	VBI60.50-73T		73
VAI60.50-96	-	-		96

DN = nominal size

k_{vs} = nominal flow rate of cold water (5...30 °C) through the fully open ball valve at a differential pressure of 100 kPa (1 bar)

Equipment combinations

Type	Rotary actuators							
	GSD..9A		GQD..9A		GMA..9E		GLB..9E	
	Δp _{max}	Δp _s	Δp _{max}	Δp _s	Δp _{max}	Δp _s	Δp _{max}	Δp _s
Ball valves	[kPa]							
VAI60.15-15	350	1400	350	1400	350	1400	350	1400
VAI60.20-22								
VAI60.25-22								
VAI60.32-35	350	1000	350	1000	350	1000	350	1000
VAI60.40-68								
VAI60.50-96								
VBI60.15-5L	350	350	350	350	350	350	350	350
VBI60.20-9L								
VBI60.25-9L								
VBI60.32-13L	350	350	350	350	350	350	350	350
VBI60.40-25L								
VBI60.50-37L								
VBI60.15-12T	350	350	350	350	350	350	350	350
VBI60.20-16T								
VBI60.25-16T								
VBI60.32-25T	350	350	350	350	350	350	350	350
VBI60.40-49T								
VBI60.50-73T								

Δp_{max} = maximum permissible differential pressure across ball valve's control path, valid for the entire actuating range of the motorized ball valve; for low noise operation, we recommend a maximum permissible differential pressure of 200 kPa

Δp_s = maximum permissible differential pressure at which the motorized ball valve will close securely against the pressure (close off pressure)

Rotary actuators for ball valves (overview)

Type / Stock no.	Actuator type	Operating voltage	Positioning		Spring return		Data Sheet
			signal	time	function	time	
GSD141.9A	Electro-motoric	AC/DC 24 V	Open/Close ¹⁾	30 s			N4655
GSD341.9A		AC 230 V					
GQD121.9A	Electro-motoric	AC/DC 24 V	2-position	30/15 s ²⁾	Yes	15 s	N4659
GQD321.9A		AC 230 V					
GMA121.9E	Electro-motoric	AC/DC 24 V	2-position	90/15 s ²⁾	Yes	15 s	N4658
GMA321.9E		AC 230 V					
GLB131.9E	Electro-motoric	AC 24 V	(2) 3-position	150 s			N4657
GLB331.9E		AC 230 V					

¹⁾ 2-wire SPDT (Single Pole Double Throw)

²⁾ open/close

Ordering

When ordering please give material, article type, purchase order text and quantity.

Example:

Material	Article Type	Purchase Order (PO) text	Quantity
VAI60.25-22	VAI60.25-22	Open/Close Ball valve inside threaded, 2-Port	2
GLB131.9E	GLB131.9E	Actuator for Ball valve, NSR	2

Spare parts, Rev. no.

See overview, page 11.

Delivery

Ball valves and rotary actuators are supplied in separate packaging and not assembled prior to delivery.

Applications with auxiliary functions

If a ball valve application requires a rotary actuator with auxiliary functions (for example switch or potentiometer), a standard actuator with a corresponding function can be used. In this case, a mounting set ASK77.. is required **in addition** to the rotary actuator.

For assembly please consult mounting instructions accordingly.

Rotary actuators	Option	Mounting set (order text)
GMA..1E (with spring-return)	Potentiometer, switches	ASK77.2 Accessory Kit BV for GMAxx1.9E
GLB..1E (without spring-return)	Potentiometer, switches	ASK77.3 Accessory Kit BV for GLBxx1.9E
GQD..1A (with spring-return)	Switches	ASK77.4 Accessory Kit for BV GQDxx1.9A
GSD..1A (without spring-return)	Switches	ASK77.4 Accessory Kit for BV GQDxx1.9A

Accessories

For thermal insulation, separate insulation covers are available.

For open/close ball valves 2-port		For changeover ball valves 3-port	
Ball valve	Insulation cover	Ball valve	Insulation cover
VAI60.15..	ALI15VAI60/61	VBI60.15..	ALI15VBI60/61
VAI60.20..	ALI20VAI60/61	VBI60.20..	ALI20VBI60
VAI60.25..	ALI25VAI60/61	VBI60.25..	ALI25VBI60/61
VAI60.32..	ALI32VAI60/61	VBI60.32..	ALI32VBI60/61
VAI60.40..	ALI40VAI60/61	VBI60.40..	ALI40VBI60/61
VAI60.50..	ALI50VAI60/61	VBI60.50..	ALI50VBI60/61

Insulation covers for
Open/close and chan-
geover ball valves



Dimensions see
page 10

Technical design

Parts

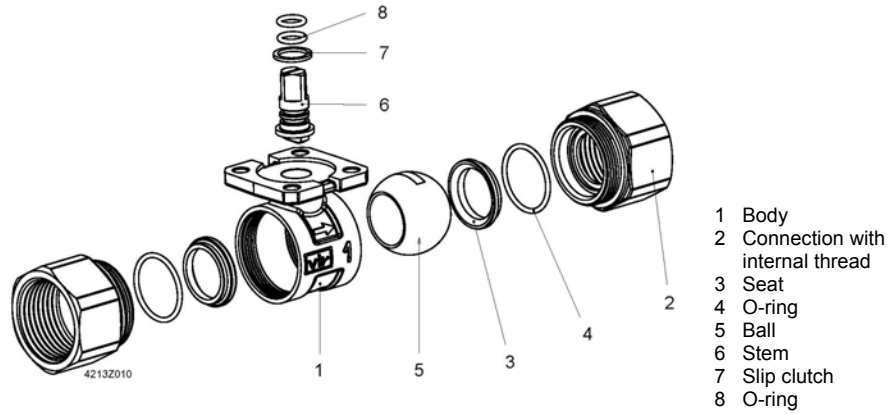

Sizing

Flow diagram

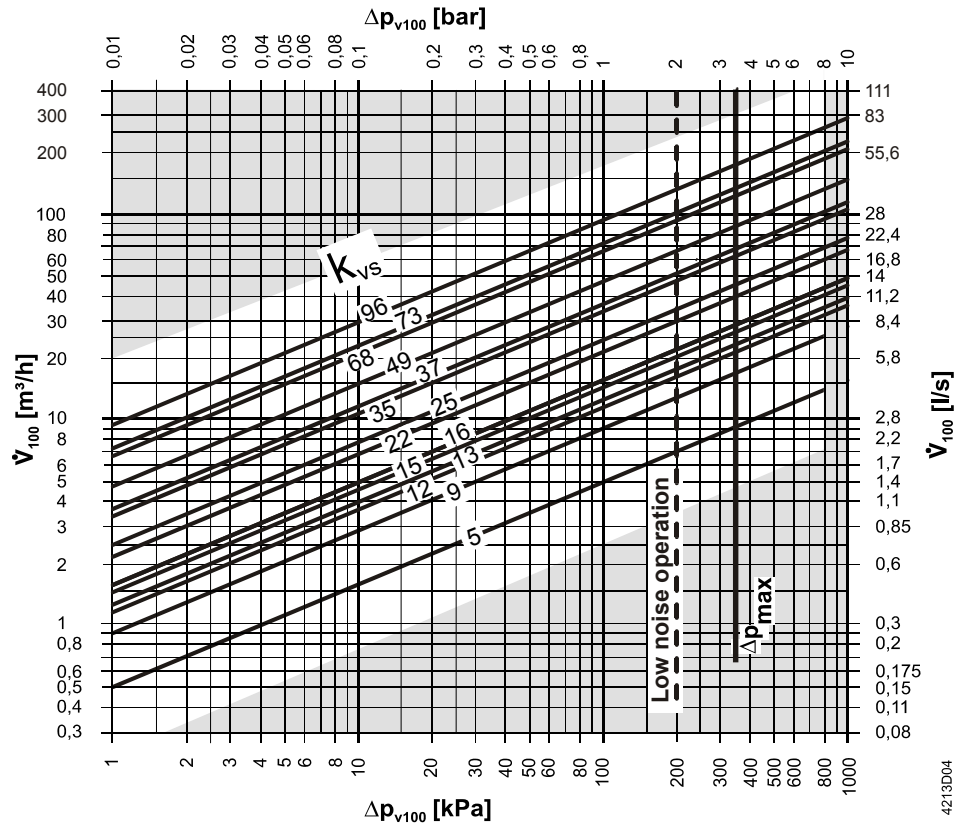

----- Δp_{max} for VAI60.. and VBI60.. see table equipment combinations for details

Δp_{max} = maximum permissible differential pressure across the ball valve, valid for the entire actuating range of the motorized ball valve; for low noise operation, we recommend a maximum permissible differential pressure of 200 kPa

- Δp_{V100} = differential pressure across the fully open ball valve and the ball valve's control path at a volumetric flow V_{100}
- \dot{V}_{100} = volumetric flow through the fully open ball valve
- 100 kPa = 1 bar \approx 10 mWC
- 1 m³/h = 0.278 l/s water at 20 °C

Cavitation

Cavitation accelerates wear on the ball and seat, and also results in undesirable noise. Cavitation can be avoided by not exceeding the differential pressure shown in the flow diagram on page 4, and by adhering to the static pressures shown below.

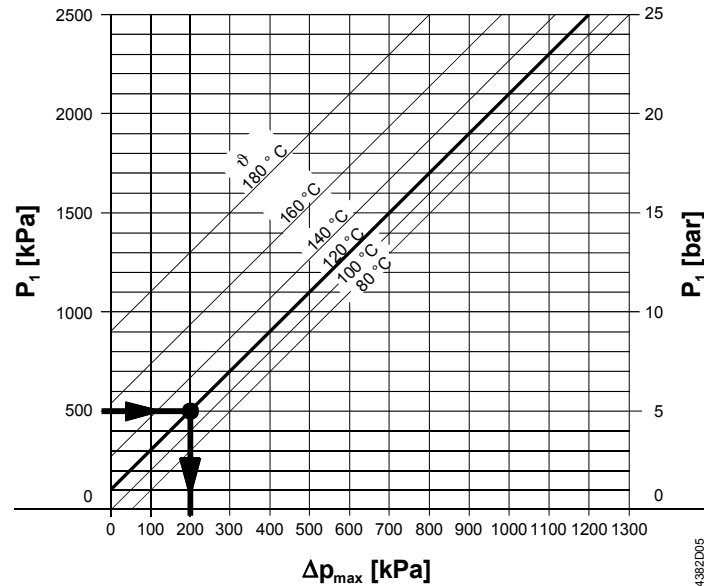

- Δp_{max} = differential pressure with ball valve almost closed at which cavitation can largely be avoided
- p_1 = static pressure at ball valve inlet
- p_3 = static pressure at ball valve outlet
- M = pump
- ϑ = water temperature

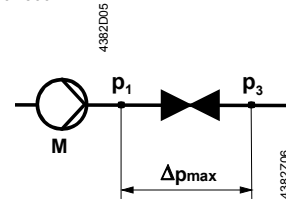

High temperature
hot water example:

Pressure p_1 at ball valve inlet: 500 kPa (5 bar)
Water temperature: 120 °C

From the diagram above, it will be seen that with the ball valve almost closed, the maximum permissible differential pressure Δp_{max} is 200 kPa (2 bar).

Note on chilled water

To avoid cavitation in chilled water circuits, ensure sufficient counter-pressure at the ball valve's outlet, e.g. with an additional throttling ball valve downstream from the ball valve. Select the maximum differential pressure across the ball valve according to the 80 °C curve in the flow diagram above.

Operating pressure and temperature
Fluids

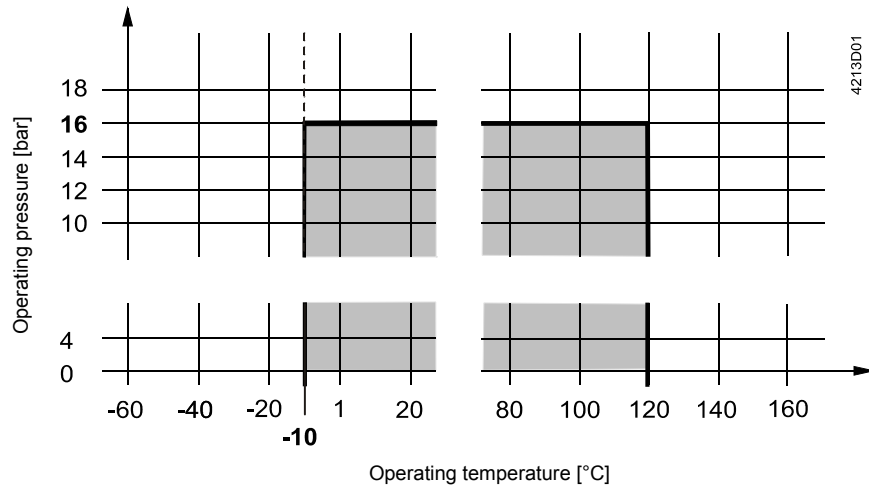

Operating pressure and medium temperature as per ISO 7005

Current local legislation must be observed.

Notes

Engineering

Ensure cavitation-free flow (refer to page 5).

Always use a strainer upstream of the ball valve to increase the ball valve's functional safety.

Mounting

Ball valve and rotary actuator can easily be assembled on site. Neither special tools nor adjustments are required.

The ball valve VAI60.., VBI60.. is supplied with Mounting Instructions M4213 (74 319 0883 0).

Orientation

VAI60..

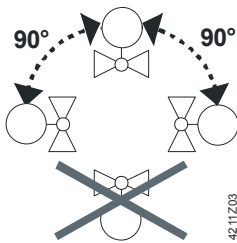

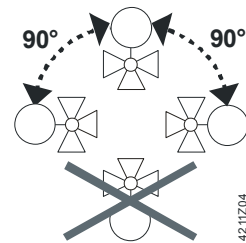

**VBI60..L
VBI60..T**

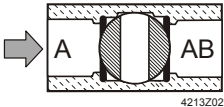

Direction of flow

When mounting, pay attention to the ball valve's flow direction symbol.

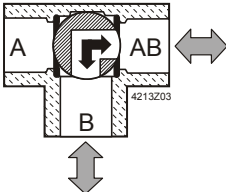
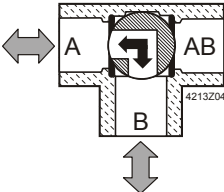
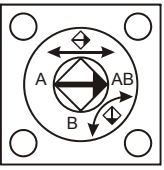
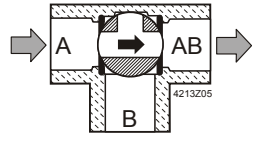
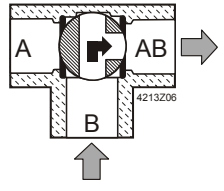
Ball valve	Laser mark	Delivery position	Turned 90° (Clockwise)
VAI60.. Open/close ball valve 2-port		 <p>A – AB = 100 %</p>	 <p>A – AB = 0 %</p>
VBI60..L Changeover ball valve 3-port (L-Type drill-hole)		 <p>B – AB (AB – B) = 100 %</p>	 <p>A – B (B – A) = 100 %</p>
VBI60..T Changeover ball valves 3-port (T-Type drill-hole)		 <p>A – AB = 100 % B – AB = 0 %</p>	 <p>A – AB = 0 % B – AB = 100 %</p>

Commissioning

Commission the ball valve only if the rotary actuator has been mounted correctly.

Maintenance

VAI60.. and VBI60.. ball valves are maintenance-free.

Warning

When doing service work on the ball valve / rotary actuator:

- Deactivate the pump and turn off the power supply
- Close the shutoff ball valves
- Fully reduce the pressure in the piping system and allow pipes to completely cool down

If necessary, disconnect the electrical wires.

Before putting the ball valve into operation again, make sure the rotary actuator is correctly fitted.

Disposal



Before disposal, the ball valve must be dismantled and separated into its various constituent materials.

Legislation may demand special handling of certain components, or it may be sensible from an ecological point of view.

Current local legislation must be observed.

Warranty

The technical data given for applications is valid only in conjunction with the Siemens rotary actuators listed under "Equipment combinations", page 2.

All terms of the warranty will be invalidated if rotary actuators of other manufacture are used.

Technical data

	VAI60..	VBI60..L	VBI60..T	
Functional data	PN class	PN 40 as per ISO 7268		
	Operating pressure	To ISO 7005 within the permissible medium temperature range according to diagram on page 6		
	Leakage rate			
	Through-port	0...0.0001 of k _{vs} value	0...0.0001 of k _{vs} value	0...0.0001 of k _{vs} value
	Bypass		0...0.0001 of k _{vs} value	< 0.01 of k _{vs} value
	Permissible media	Cold water, chilled water, low temperature hot water, high temperature hot water, water with anti-freeze. Recommendation: water treatment to VDI 2035		
	Medium temperature	-10...120 °C		
Angle of rotation	90 °			
Materials	Ball valve body	Dezincification resistant hot-pressed brass (DZR), CW602N		
	Ball	Dezincification resistant hot-pressed brass (DZR), CW602N, chromium-plated		
	Stem	Dezincification resistant hot-pressed brass (DZR), CW602N		
	Gland	EPDM O-rings		
Dimensions / weight	Refer to "Dimensions" page 9			
	Internally threaded connections	Rp as per ISO 7-1		
Standards	Pressure Equipment Directive	PED 97/23/EC		
	Pressure accessories	As per article 1, section 2.1.4		
	Fluid group 2	Without CE marking as per article 3, section 3 (sound engineering practice)		
	Environmental compatibility	ISO 14001 (Environment) ISO 9001 (Quality) SN 36350 (Environmentally compatible products) RL 2002/95/EC (RoHS)		

Dimensions

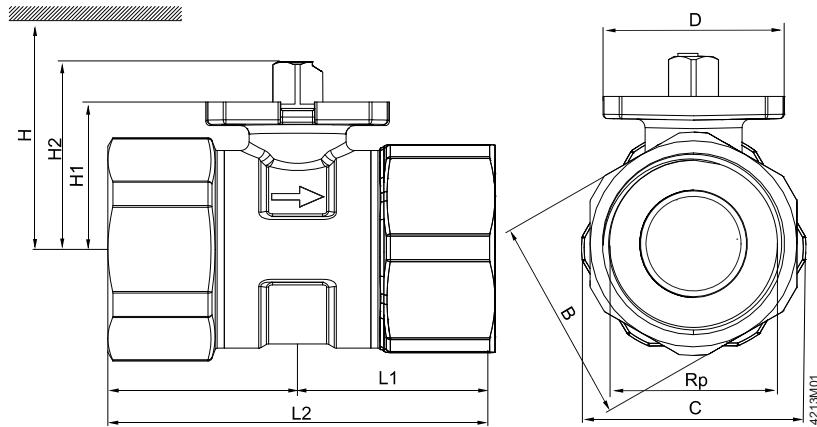

DN = Nominal size
H = Total actuator height plus minimum distance to the wall or the ceiling for mounting, connection, operation, service, etc.
H1 = Dimension from the pipe centre to install the actuator (upper edge)

Type	DN	B [mm]	C [mm]	D [mm]	Rp [Inch]	L1 [mm]	L2 [mm]	H1 [mm]	H2 [mm]	GSD..9A [mm]	GQD..9A [mm]	H		kg [kg]
												GMA..9E [mm]	GLB..9E [mm]	
VAI60.15-15	15	26	31 ¹⁾	42	Rp ½	30.8	61.6	27.6	37.6	> 300	> 300	>300	>300	0.28
VAI60.20-22	20	31	38	42	Rp ¾	33.5	67	30.5	40.5			>310	>310	0.36
VAI60.25-22	25	39	42.5	42	Rp 1	38.4	76.8	30.5	40.5					0.46
VAI60.32-35	32	48	52	42	Rp 1¼	44	88	34.3	44.3					0.7
VAI60.40-68	40	55	61	42	Rp 1½	50.9	101.8	39.8	49.8					1.1
VAI60.50-96	50	67	74	42	Rp 2	58.1	116.2	52.8	62.8					1.74

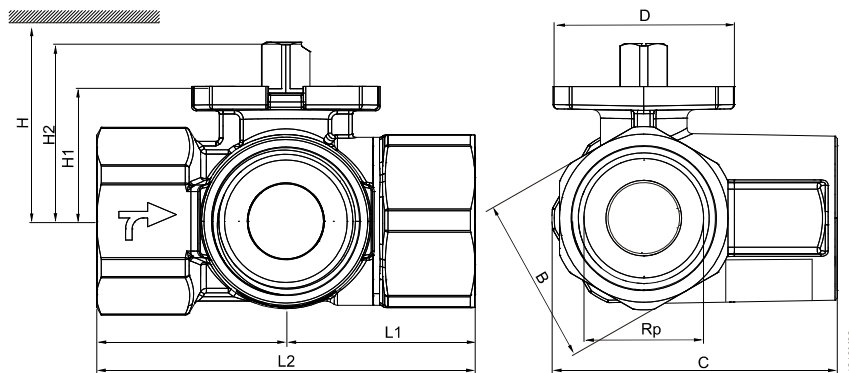

DN = Nominal size
H = Total actuator height plus minimum distance to the wall or the ceiling for mounting, connection, operation, service, etc.
H1 = Dimension from the pipe centre to install the actuator (upper edge)

Type	DN	B [mm]	C [mm]	D [mm]	Rp [Inch]	L1 [mm]	L2 [mm]	H1 [mm]	H2 [mm]	GSD..9A [mm]	GQD..9A [mm]	H		kg [kg]
												GMA..9E [mm]	GLB..9E [mm]	
VBI60.15-5L	15	26	49.5	42	Rp ½	33.3	66.6	27.6	37.6	> 300	> 300	>300	>300	0.32
VBI60.20-9L	20	39	61.05	42	Rp ¾	40.2	80.4	30.5	40.5			>310	>310	0.73
VBI60.25-9L	25	39	66.5	42	Rp 1	42.7	85.4	30.5	40.5					0.62
VBI60.32-13L	32	48	78.6	42	Rp 1¼	49.6	99.2	34.3	44.3					0.97
VBI60.40-25L	40	55	87.6	42	Rp 1½	54.8	109.6	39.8	49.8					1.43
VBI60.50-37L	50	67	105.9	42	Rp 2	65.7	131.4	52.8	62.8					2.36
VBI60.15-12T	15	26	49.5	42	Rp ½	33.3	66.6	27.6	37.6	> 300	> 300	>300	>300	0.31
VBI60.20-16T	20	39	61.05	42	Rp ¾	40.2	80.4	30.5	40.5			>310	>310	0.74
VBI60.25-16T	25	39	66.5	42	Rp 1	42.7	85.4	30.5	40.5					0.63
VBI60.32-25T	32	48	78.6	42	Rp 1¼	49.6	99.2	34.3	44.3					0.69
VBI60.40-49T	40	55	87.6	42	Rp 1½	54.8	109.6	39.8	49.8					1.38
VBI60.50-73T	50	67	105.9	42	Rp 2	65.7	131.4	52.8	62.8					2.26

¹⁾ Body larger than union nut

Dimensions with
insulation covers for
open/close ball valves
2-port

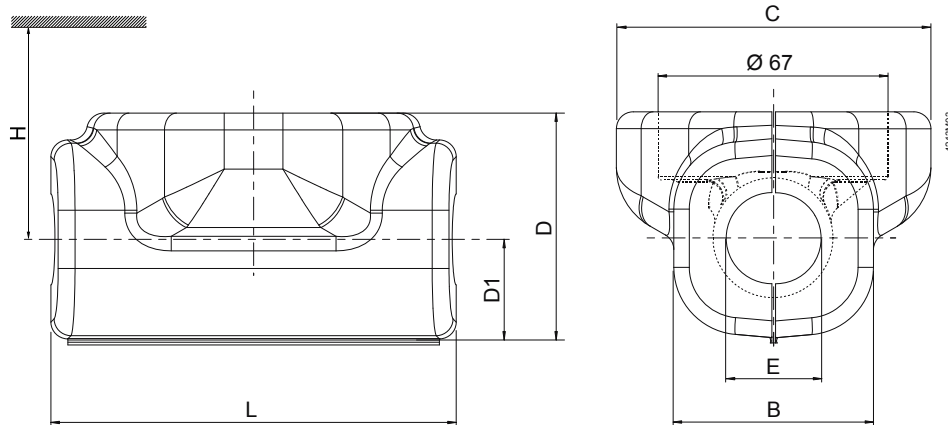

DN = Nominal size
H = Total actuator height
plus minimum
distance to the wall
or the ceiling
for mounting, operation,
service, etc.

Insulation cover	Type to ball valve	DN	B [mm]	C [mm]	D [mm]	D1 [mm]	E [mm]	L [mm]	H				kg [g]
									GSD..9A [mm]	GQD..9A [mm]	GMA..9E [mm]	GLB..9E [mm]	
ALI15VAI60/61	VAI60.15-15	15	56	95	65	27	21	100	> 300	> 300	>300	>300	15
ALI20VAI60	VAI60.20-22	20	56	95	66	32	27	105			16		
ALI25VAI60/61	VAI60.25-22	25	56	95	80	37	34	108			>310	>310	20
ALI32VAI60/61	VAI60.32-35	32	86	100	95	47	43	130					28
ALI40VAI60/61	VAI60.40-68	40	95	102	98	50	48	140			>320	>320	32
ALI50VAI60/61	VAI60.50-96	50	105	96	110	56	61	160			>335	>335	36

Dimensions with
insulation covers for
changeover ball valves
3-port

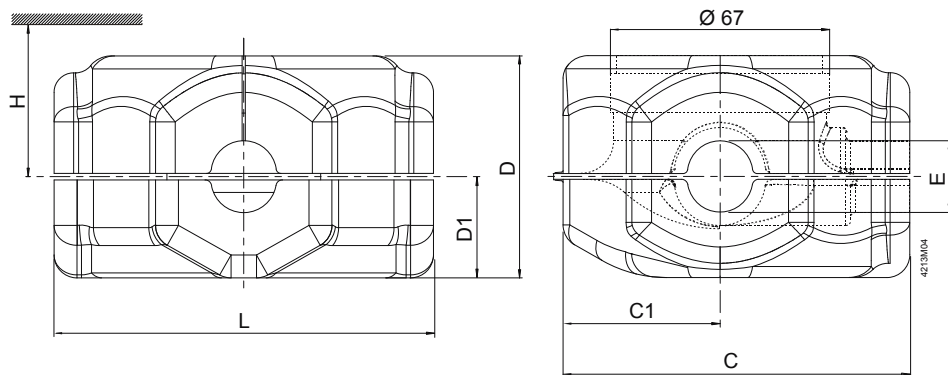

DN = Nominal size
H = Total actuator height
plus minimum
distance to the wall
or the ceiling
for mounting, operation,
service, etc.

Insulation cover	Type to ball valve	DN	C [mm]	C1 [mm]	D [mm]	D1 [mm]	E [mm]	L [mm]	H				kg [g]
									GSD..9A [mm]	GQD..9A [mm]	GMA..9E [mm]	GLB..9E [mm]	
ALI15VBI60/61	VBI60.15..	15	100	50	70	34	21	100	> 300	> 300	>300	>300	21
ALI20VBI60	VBI60.20..	20	115	55	80	40	27	120			30		
ALI25VBI60/61	VBI60.25..	25	115	55	80	40	34	120			>310	>310	30
ALI32VBI60/61	VBI60.32..	32	125	55	95	45	43	150					41
ALI40VBI60/61	VBI60.40..	40	125	55	95	45	48	150			>320	>320	43
ALI50VBI60/61	VBI60.50..	50	145	60	110	54	61	170			>320	>320	51

Revision numbers

Open/close ball valves 2-port	Type		Valid from rev. no.
	Changeover ball valves 3-port (L)	Changeover ball valves 3-port (T)	
-	VBI60.15-5L	-	..A
-	-	VBI60.15-12T	..A
VAI60.15-15	-	-	..A
-	VBI60.20-9L	-	..A
-	-	VBI60.20-16T	..A
VAI60.20-22	-	-	..A
-	VBI60.25-9L	-	..A
-	-	VBI60.25-16T	..A
VAI60.25-22	-	-	..A
-	VBI60.32-13L	-	..A
-	-	VBI60.32-25T	..A
VAI60.32-35	-	-	..A
-	VBI60.40-25L	-	..A
-	-	VBI60.40-49T	..A
VAI60.40-68	-	-	..A
-	VBI60.50-37L	-	..A
-	-	VBI60.50-73T	..A
VAI60.50-96	-	-	..A

